

# Digital proportional directional valves high performance

piloted, with on-board driver, LVDT transducer and positive spool overlap

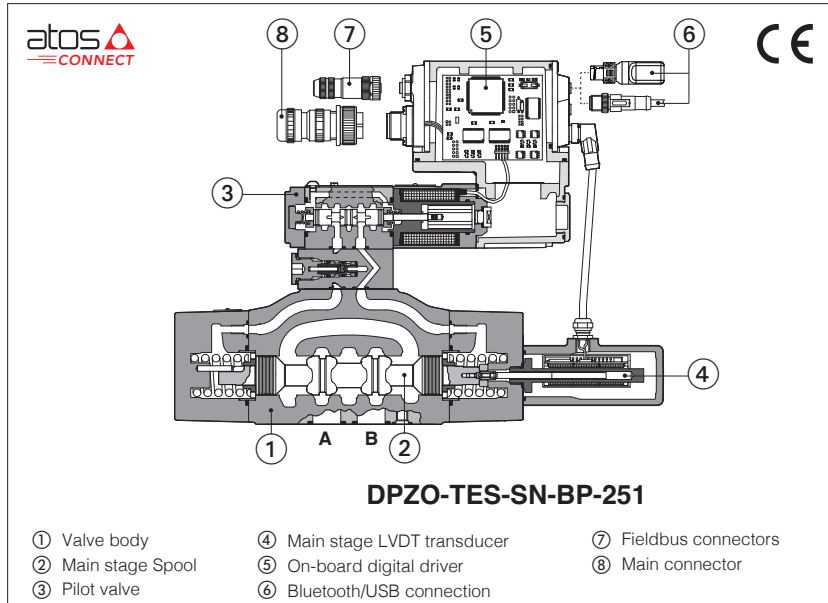

## DPZO-TEB, DPZO-TEB

Digital proportional directional valves, piloted, specifically designed for directional and speed controls.

They are equipped with one LVDT position transducer (main stage) and positive spool overlap for best dynamics in directional controls and not compensated flow regulations.

**TEB** basic execution with analog reference signal or IO-Link interface for digital reference signals, valve settings, and real-time diagnostics.

**TES** full execution which includes also optional fieldbus interfaces for digital reference signals, valve settings, and real-time diagnostics.

Bluetooth/USB connection is always present for valve settings via mobile App and Atos PC software.

Size: **10 ÷ 32** - ISO 4401  
 Max flow: **180 ÷ 1600 l/min**  
 Max pressure: **350 bar**

### 1 MODEL CODE

<b>DPZO</b>	-	<b>TES</b>	-	<b>SN</b>	-	<b>NP</b>	-	<b>2</b>	-	<b>71</b>	-	<b>L</b>	-	<b>5</b>	/	*	/	*	/	*	/	*
<p>Proportional directional valve, piloted</p> <p><b>TEB</b> = basic on-board digital driver  <b>TES</b> = full on-board digital driver</p> <p><b>Alternated P/Q controls:</b>  <b>SN</b> = none</p> <p><b>IO-Link interface</b>, only for TEB, see section [6]:  <b>NP</b> = Not present    <b>IL</b> = IO-Link</p> <p><b>Fieldbus interfaces</b>, only for TES, see section [7]:  <b>NP</b> = Not present    <b>EW</b> = POWERLINK  <b>BC</b> = CANopen        <b>EI</b> = EtherNet/IP  <b>BP</b> = PROFIBUS DP    <b>EP</b> = PROFINET RT/IRT  <b>EH</b> = EtherCAT</p> <p><b>Valve size ISO 4401:</b>  <b>1</b> = 10    <b>2</b> = 16    <b>4</b> = 25    <b>6</b> = 32</p>																						
<p><b>Series number</b></p> <p><b>Seals material</b>, see section [12]:          - = NBR  <b>PE</b> = FKM  <b>BT</b> = NBR low temperature</p> <p><b>Safety options</b> TÜV certified - only for TES (3):  <b>U</b> = safe double power supply  <b>K</b> = safe on/off signals          See section [8] <span style="float: right;"><b>SAFETY CERTIFIED</b></span></p> <p><b>Bluetooth option (2)</b>, see section [5]:  <b>T</b> = Bluetooth adapter supplied with the valve</p> <p><b>Hydraulic options (3):</b>  <b>B</b> = solenoid with on-board digital driver and LVDT transducer at side of port A of the main stage (side B of pilot valve)  <b>D</b> = internal drain  <b>E</b> = external pilot pressure</p> <p><b>Electronic options (3)</b>, not available for TEB-SN-IL:  <b>F</b> = fault signal  <b>I</b> = current reference input and monitor 4÷20mA  <b>Q</b> = enable signal  <b>Z</b> = double power supply (only for TES), enable, fault and monitor signals - 12 pin connector</p>																						

### Configuration (1):

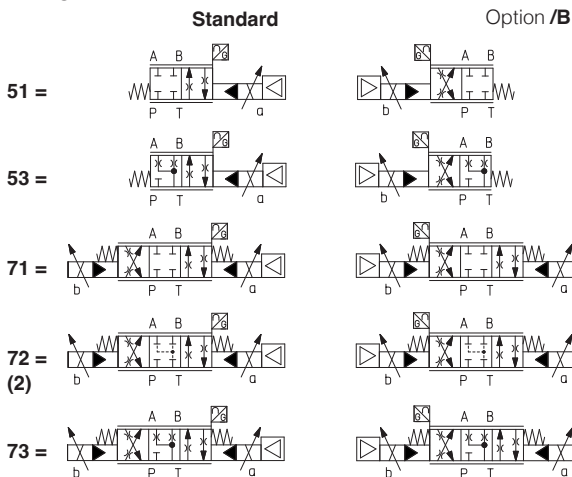

Spool size:	3	5	5	5
Spool type:	L, S, D	L, DL, S, D	L, S, D	L, S, D
Configuration:	51,53,71,73	51,53,71,73	51,53,71,73	72
DPZO-1 =	-	100	-	-
DPZO-2 =	160	250	-	250
DPZO-4 =	-	480	-	480
DPZO-6 =	-	-	640	-

Nominal flow (l/min) at Δp 10 bar P-T (see section [13])

### Spool type, regulating characteristics, see section [16]:

<b>L</b> = linear	<b>S</b> = progressive
<b>DL</b> = differential-linear	<b>D</b> = differential-progressive
P-A = Q, B-T = Q/2	P-A = Q, B-T = Q/2
P-B = Q/2, A-T = Q	P-B = Q/2, A-T = Q

(1) For regenerative circuit select configuration 71 or 73 with specific spools D9 or L9, see section [2]  
 (2) Only for DPZO sizes 2, 4 with spools L5, S5 or D5, see 13.5  
 (3) For possible combined option, see section [16]

**2 SPOOLS SPECIFIC FOR REGENERATIVE CIRCUIT** - for valve model code and options, see section 1

**DPZO** - **TES** - **SN** - **NP** - **2** **71 - L9** / \* / \* / \* \* / \*

**Configuration and spool:**

**71-D9**

**71-L9**

**73-D9**

**73-L9**

**Spool type and size: D9 L9**

DPZO-1	=	100	-
DPZO-2	=	250	250
DPZO-4	=	480	-

Nominal flow (l/min) at Δp 10bar P-T

**D9**

For regenerative circuit (additional external check valve required)  
see 13.1 - diagram 19

**L9**

For regenerative circuit internal to the valve  
see 13.1 - diagram 20

**3 GENERAL NOTES**

Atos digital proportionals valves are CE marked according to the applicable directives (e.g. Immunity and Emission EMC Directive). Installation, wirings and start-up procedures must be performed according to the general prescriptions shown in tech table **FS900** and in the user manuals included in the E-SW-SETUP programming software.

**4 VALVE SETTINGS AND PROGRAMMING TOOLS** - see tech. table **GS500**

**4.1 Atos CONNECT mobile App**

Free downloadable App for smartphones and tablets which allows quick access to valve main functional parameters and basic diagnostic information via Bluetooth, thus avoiding physical cable connection and significantly reducing commissioning time. Atos CONNECT supports Atos digital valve drivers equipped with E-A-BTH adapter or with built-in Bluetooth. It does not support valves with p/Q control or axis controls.



**4.2 E-SW-SETUP PC software**

Free downloadable software for PC allows to set all valve functional parameters and to access complete diagnostic information of digital valve drivers via Bluetooth/USB service port. Atos E-SW-SETUP PC software supports all Atos digital valve drivers and it is available at [www.atos.com](http://www.atos.com) in MyAtos area.

**WARNING: drivers USB port is not isolated!** For E-C-SB-USB/M12 cable, the use of E-A-SB-USB/OPT isolator adapter is highly recommended for PC protection

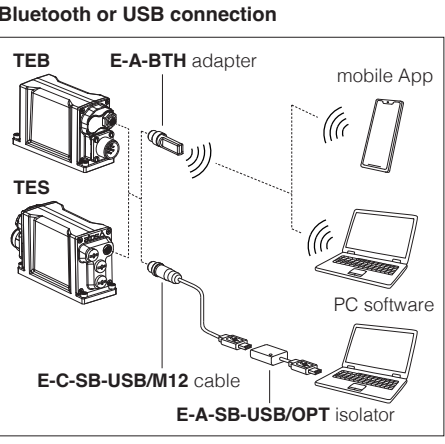

**5 BLUETOOTH OPTION** - see tech. table **GS500**

T option adds Bluetooth® connectivity to Atos valve drivers thanks to E-A-BTH adapter, which can be left permanently installed on-board, to allow the Bluetooth connection with the valve drivers at any time. E-A-BTH adapter can also be purchased separately and used to connect with any supported Atos digital product. Bluetooth connection to the valve can be protected against unauthorised access by setting a personal password. The adapter leds visually indicates the status of valve driver and Bluetooth connection.

**WARNING:** for the list of countries where the Bluetooth adapter has been approved, see tech. table **GS500**  
T option is not available for the Indian market, so the Bluetooth adapter must be ordered separately.

**6 IO-LINK** - only for **TEB**, see tech. table **GS520**

IO-Link allows low cost digital communication between the valve and machine central unit. The valve is directly connected to a port of an IO-Link master (point-to-point connection) via low-cost unshielded cables for digital reference, diagnostic and settings. The IO-Link master works as a hub exchanging this information with the machine central unit via fieldbus.

**7 FIELDBUS** - only for **TES**, see tech. table **GS510**

Fieldbus allows valve direct communication with machine control unit for digital reference, valve diagnostics and settings. These execution allow to operate the valves through fieldbus or analog signals available on the main connector.

**8 SAFETY OPTIONS** - only for **TES**

Atos range of proportional directional valves, provides functional safety options **/U** and **/K**, designed to accomplish a safety function, intended to reduce the risk in process control systems. They are **TÜV certified** in compliance to **IEC 61508 up to SIL 3** and **ISO 13849 up to category 4, PL e**



**Safe double power supply**, option **/U**: the driver has separate power supplies for logic and solenoids. The safe condition is reached by cutting the electrical supply to solenoids, while electronics remains active for monitoring functions and fieldbus communication, see tech table **FY100**

**Safety function via on/off signals**, option **/K**: upon a disable command, the driver checks the spool position and it provides an on/off acknowledgement signal only when the valve is in safe condition, see tech table **FY200**

## 9 GENERAL CHARACTERISTICS

Assembly position	Any position
Subplate surface finishing to ISO 4401	Acceptable roughness index: Ra ≤0,8, recommended Ra 0,4 – Flatness ratio 0,01/100
MTTFd valves according to EN ISO 13849	75 years, for further details see technical table P007
Ambient temperature range	<b>Standard</b> = -20°C ÷ +60°C <b>/PE option</b> = -20°C ÷ +60°C <b>/BT option</b> = -40°C ÷ +60°C
Storage temperature range	<b>Standard</b> = -20°C ÷ +70°C <b>/PE option</b> = -20°C ÷ +70°C <b>/BT option</b> = -40°C ÷ +70°C
Surface protection	Zinc coating with black passivation, galvanic treatment (driver housing)
Corrosion resistance	Salt spray test (EN ISO 9227) > 200 h
Vibration resistance	See technical table G004
Compliance	CE according to EMC directive 2014/30/EU (Immunity: EN 61000-6-2; Emission: EN 61000-6-3) RoHS Directive 2011/65/EU as last update by 2015/863/EU REACH Regulation (EC) n°1907/2006

## 10 HYDRAULIC CHARACTERISTICS - based on mineral oil ISO VG 46 at 50 °C

Valve model	DPZO*-1	DPZO*-2	DPZO*-4	DPZO*-6		
Pressure limits [bar]	ports <b>P, A, B, X</b> = 350; <b>T</b> = 250 (10 for option /D); <b>Y</b> = 10;					
Spool type and size	standard	<b>L5, DL5, S5, D5</b>	<b>L3, S3, D3</b>	<b>L5, DL5, S5, D5</b>	<b>L5, S5, D5</b>	
	regenerative	<b>D9</b>		<b>D9, L9</b>	<b>D9</b>	
Nominal flow Δp P-T <b>(1)</b>	[l/min]					
	Δp= 10 bar	100	160	250	480	640
	Δp= 30 bar	160	270	430	830	1100
	Max permissible flow	180	400	550	1000	1600
Piloting pressure [bar]	min. = 25; max = 350					
Piloting volume [cm³]	1,4	3,7	9,0	21,6		
Piloting flow <b>(2)</b> [l/min]	1,7	3,7	6,8	14,4		
Leakage <b>(3)</b>	Pilot [cm³]	100 / 300	100 / 300	200 / 500	900 / 2800	
	Main stage [l/min]	0,15 / 0,5	0,2 / 0,6	0,3 / 1,0	1,0 / 3,0	
Response time <b>(4)</b> [ms]	≤ 60	≤ 75	≤ 90	≤ 120		
Hysteresis	≤ 1 [% of max regulation]					
Repeatability	± 0,5 [% of max regulation]					
Thermal drift	zero point displacement < 1% at ΔT = 40°C					

**(1)** For different Δp, the max flow is in accordance to the diagrams in section 13.2

**(3)** At p = 100/350 bar

**(2)** With step reference input signal 0 ÷ 100 %

**(4)** 0-100% step signal see detailed diagrams in section 13.3

## 11 ELECTRICAL CHARACTERISTICS

Power supplies	Nominal : +24 VDC Rectified and filtered : VRMS = 20 ÷ 32 VMAX (ripple max 10 % VPP)				
Max power consumption	50 W				
Max. solenoid current	2,6 A				
Coil resistance R at 20°C	3 ÷ 3,3 Ω				
Analog input signals	Voltage: range ±10 Vdc (24 VMAX tolerant) Current: range ±20 mA		Input impedance: Ri > 50 kΩ Input impedance: Ri = 500 Ω		
Monitor outputs	Output range: voltage ±10 VDC @ max 5 mA current ±20 mA @ max 500 Ω load resistance				
Enable input	Range: 0 ÷ 5 VDC (OFF state), 9 ÷ 24 VDC (ON state), 5 ÷ 9 VDC (not accepted); Input impedance: Ri > 10 kΩ				
Fault output	Output range: 0 ÷ 24 VDC (ON state > [power supply - 2 V] ; OFF state < 1 V ) @ max 50 mA; external negative voltage not allowed (e.g. due to inductive loads)				
Alarms	Solenoid not connected/short circuit, cable break with current reference signal, over/under temperature, valve spool transducer malfunctions, alarms history storage function				
Insulation class	H (180°) Due to the occurring surface temperatures of the solenoid coils, the European standards ISO 13732-1 and EN982 must be taken into account				
Protection degree to DIN EN60529	IP66 / IP67 with mating connectors				
Duty factor	Continuous rating (ED=100%)				
Tropicalization	Tropical coating on electronics PCB				
Additional characteristics	Short circuit protection of solenoid's current supply; 3 leds for diagnostic (only for TES); spool position control by P.I.D. with rapid solenoid switching; protection against reverse polarity of power supply				
Communication interface	USB	IO-Link	CANopen	PROFIBUS DP	EtherCAT POWERLINK EtherNet/IP PROFINET IO RT/IRT
	Atos ASCII coding	Interface and System Specification 1.1.3	EN50325-4 + DS408	EN50170-2/IEC61158	IEC 61158
Communication physical layer	not insulated USB 2.0+USB OTG	SDCI class port B	optical insulated CAN ISO11898	optical insulated RS485	Fast Ethernet, insulated 100 Base TX
Recommended wiring cable	LIYCY shielded cables, see section 20				

**Note:** a maximum time of 800 ms (depending on communication type) has to be considered between the driver energizing with the 24 Vdc power supply and when the valve is ready to operate. During this time the current to the valve coils is switched to zero.

**12 SEALS AND HYDRAULIC FLUIDS** - for other fluids not included in below table, consult our technical office

Seals, recommended fluid temperature	NBR seals (standard) = -20°C ÷ +60°C, with HFC hydraulic fluids = -20°C ÷ +50°C FKM seals (/PE option) = -20°C ÷ +80°C NBR low temp. seals (/BT option) = -40°C ÷ +60°C, with HFC hydraulic fluids = -20°C ÷ +50°C		
Recommended viscosity	20 ÷ 100 mm <sup>2</sup> /s - max allowed range 15 ÷ 380 mm <sup>2</sup> /s		
Max fluid contamination level	normal operation	ISO4406 class 18/16/13 NAS1638 class 7	see also filter section at www.atos.com or KTF catalog
	longer life	ISO4406 class 16/14/11 NAS1638 class 5	
Hydraulic fluid	Suitable seals type	Classification	Ref. Standard
Mineral oils	NBR, FKM, NBR low temp.	HL, HLP, HLPD, HVLP, HVLPD	DIN 51524
Flame resistant without water	FKM	HFDU, HFDR	ISO 12922
Flame resistant with water	NBR, NBR low temp.	HFC	

**13 DIAGRAMS** (based on mineral oil ISO VG 46 at 50 °C)

**13.1 Regulation diagrams** (values measure at Δp 10 bar P-T)

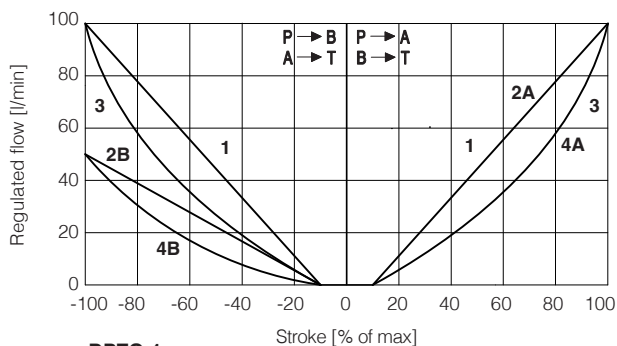

**DPZO-1:**  
**1** = L5    **2A** = DL5 (P → A, A → T)    **4A** = D5 (P → A, A → T)  
**3** = S5    **2B** = DL5 (P → B, B → T)    **4B** = D5 (P → B, B → T)

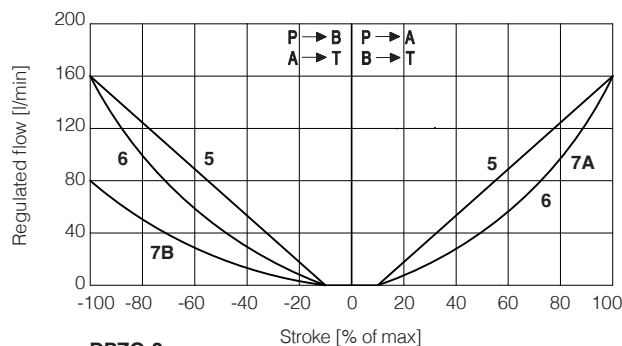

**DPZO-2:**  
**5** = L3    **7A** = D3 (P → A, A → T)  
**6** = S3    **7B** = D3 (P → B, B → T)

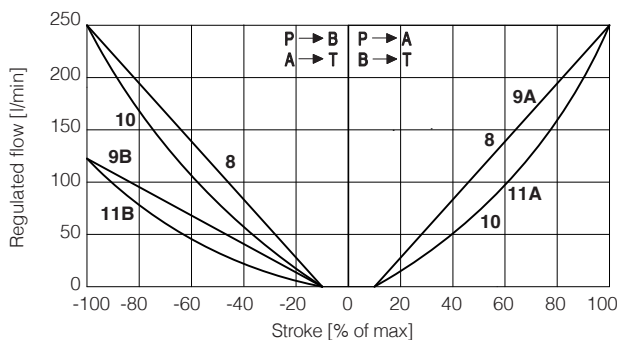

**DPZO-3:**  
**8** = L5    **9A** = DL5 (P → A, A → T)    **11A** = D5 (P → A, A → T)  
**10** = S5    **9B** = DL5 (P → B, B → T)    **11B** = D5 (P → B, B → T)

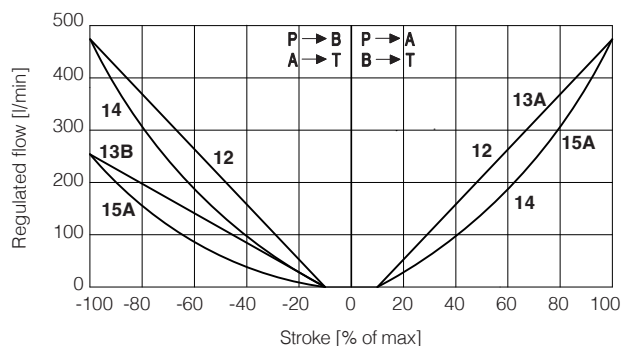

**DPZO-4:**  
**12**=L5    **13A**=DL5 (P → A, A → T)    **15A**=D5 (P → A, A → T)  
**14**=S5    **13B**=DL5 (P → B, B → T)    **15B**=D5 (P → B, B → T)

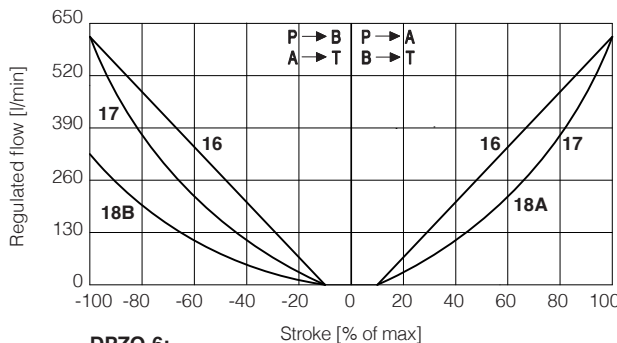

**DPZO-6:**  
**16** = L5    **18A** = D5 (P → A, A → T)  
**17** = S5    **18B** = D5 (P → B, B → T)

**Note:**

Hydraulic configuration vs. reference signal (standard and option /B)

Reference signal  $\left. \begin{matrix} 0 \div +10 \text{ V} \\ 12 \div 20 \text{ mA} \end{matrix} \right\} P \rightarrow A / B \rightarrow T$

Reference signal  $\left. \begin{matrix} 0 \div -10 \text{ V} \\ 12 \div 4 \text{ mA} \end{matrix} \right\} P \rightarrow B / A \rightarrow T$

**19 = differential - regenerative spool D9**  
(not available for valve size 32)

D9 spool type with a fourth position specific to regenerative circuit, performed by means of an additional external check valve.

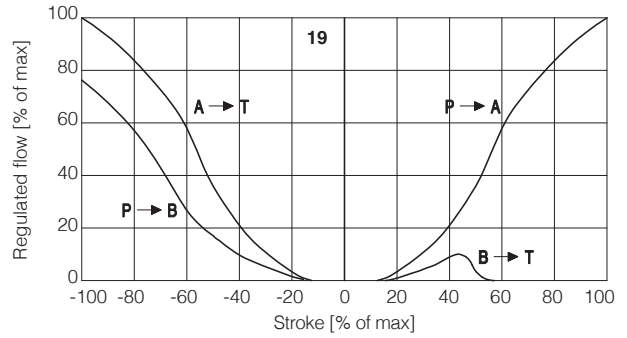
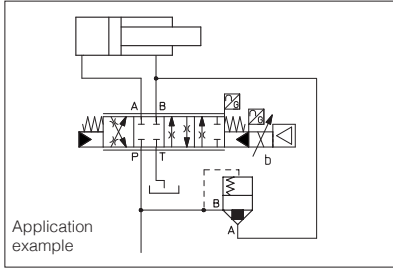

**20 = linear - internal regenerative spool L9**  
(available only for valve size 16)

L9 spool type with a fourth position specific to perform a regenerative circuit internal to the valve.

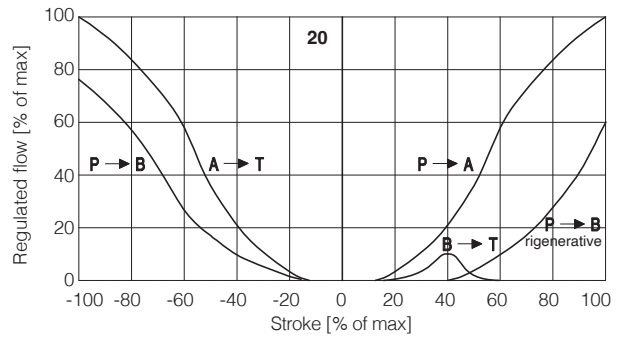

**13.2 Operating diagrams**

**Flow / Δp diagram** stated at 100% of spool stroke

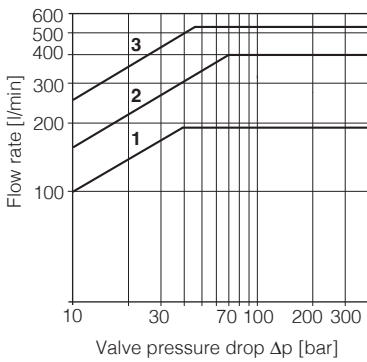

**DPZO-1:**  
1 = spools L5, S5, D5, DL5, D9  
**DPZO-2:**  
2 = spools L3, S3, D3  
3 = spools L5, S5, D5, DL5, D9, L9

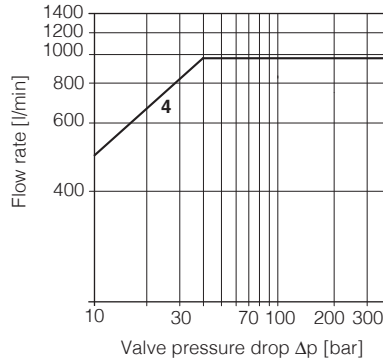

**DPZO-4:**  
4 = spools L5, S5, D5, DL5, D9

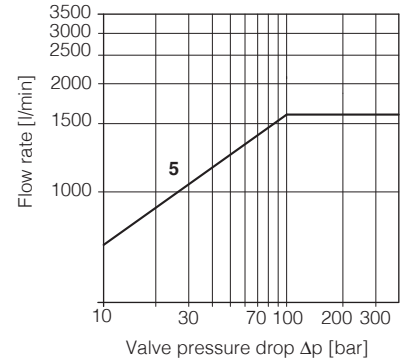

**DPZO-6:**  
6 = L5, S5, D5

**13.3 Response time**

The response times in below diagrams are measured at different steps of the reference input signal. They have to be considered as average values.

For the valves with digital electronics the dynamics performances can be optimized by setting the internal software parameters.

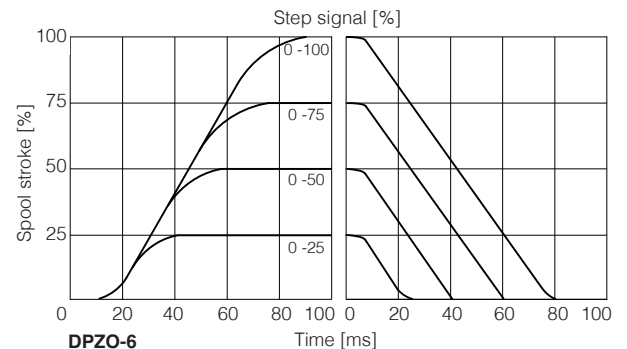
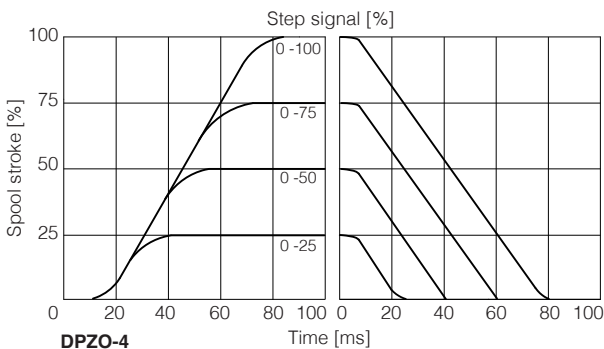
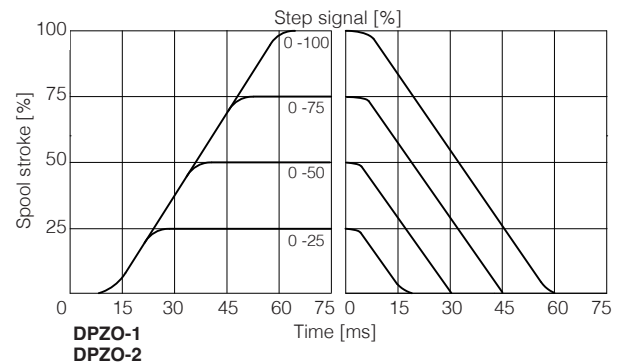

### 13.4 Operation as throttle valve

Single solenoid valves (\*51) can be used as simple throttle valves:  
 $P_{max} = 250 \text{ bar}$

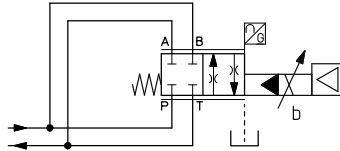

DPZO-*	151-L5	251-L5	451-L5	651-L5
Max flow [l/min]	320	860	1600	2200
$\Delta p = 15 \text{ bar}$				

### 13.5 Configuration 72

Only for **DPZO** sizes **2, 4** with spools **L5** or **S5**: in central position the leakages P-A and P-B are drained to tank, avoiding the drift of cylinders with differential areas.

## 14 HYDRAULIC OPTIONS

**B** = Solenoid, on-board digital driver and LVDT transducer at side of port A of the main stage (side B of pilot valve). For hydraulic configuration vs reference signal, see 13.1

**D** = Internal drain (through port T).

Pilot and drain configuration can be modified as shown in the functional scheme here aside. For detailed view of plugs position, see section 22  
 The valve's standard configuration provides internal pilot and external drain.

**E** = External pilot (through port X).

Pilot and drain configuration can be modified as shown in the functional scheme here aside. For detailed view of plugs position, see section 22  
 The valve's standard configuration provides internal pilot and external drain.

- |               |  |
|---------------|--|
| ① Pilot valve | ③ Pressure reducing valve                              |
| ② Main stage  | ④ Plug to be added for external pilot trough port X    |
|               | ⑤ Plug to be removed for internal drain through port T |

Functional Scheme - example of configuration 71

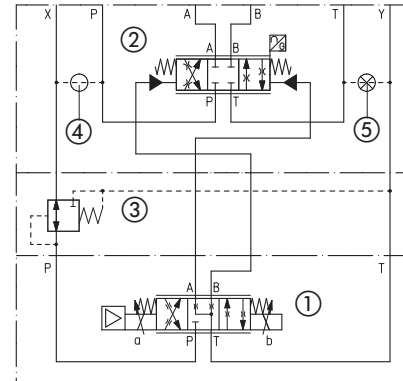

## 15 ELECTRONIC OPTIONS - not available for **TEB-SN-IL**

**F** = This option permits to monitor the eventual fault condition of the driver, as for example the solenoid short circuit/not connected, reference signal cable broken for option /I, spool position transducer broken, etc. - see 17.7 for signal specifications.

**I** = This option provides 4 ÷ 20 mA current reference and monitor signals, instead of the standard  $\pm 10 \text{ VDC}$ .

Input signal can be reconfigured via software selecting between voltage and current, within a maximum range of  $\pm 10 \text{ VDC}$  or  $\pm 20 \text{ mA}$ .  
 It is normally used in case of long distance between the machine control unit and the valve or where the reference signal can be affected by electrical noise; the valve functioning is disabled in case of reference signal cable breakage.

**Q** = This option permits to inhibit the valve function without removing the power supply to the driver. Upon disable command the current to the solenoid is zeroed and the valve's spool moves to rest position.

The option /Q is suggested for all cases where the valve has to be frequently inhibited during the machine cycle – see 17.5 for signal specifications.

**Z** = This option provides, on the 12 pin main connector, the following additional features:

**Fault output signal** - see above option **/F**

**Enable input signal** - see above option **/Q**

**Repeat enable output signal** - only for **TEB-SN-NP** (see 17.6)

**Power supply for driver's logics and communication** - only for **TES** (see 17.2)

## 16 POSSIBLE COMBINED OPTIONS

**Hydraulic options:**

all combination possible

**Electronic options** - Standard versions:

**TEB-SN, TES-SN**

/F, /I, /Z

**Electronic options** - Safety certified versions:

**TES-SN**

/I, /U, /K

**Note:** /T Bluetooth adapter option can be combined with all other options

## 17 POWER SUPPLY AND SIGNALS SPECIFICATIONS

Generic electrical output signals of the valve (e.g. fault or monitor signals) must not be directly used to activate safety functions, like to switch-ON/OFF the machine's safety components, as prescribed by the European standards (Safety requirements of fluid technology systems and components-hydraulics, ISO 4413).

For **TEB-SN-IL** signals see section 18

For certified safety options: **/U** see tech. table **FY100** and **/K** see tech. table **FY200**

### 17.1 Power supply (V+ and V0)

The power supply must be appropriately stabilized or rectified and filtered: apply at least a 10000  $\mu\text{F}/40\text{ V}$  capacitance to single phase rectifiers or a 4700  $\mu\text{F}/40\text{ V}$  capacitance to three phase rectifiers. In case of separate power supply see 17.2.



A safety fuse is required in series to each power supply: 2,5 A time lag fuse.

### 17.2 Power supply for driver's logic and communication (VL+ and VL0) - only for **TES** with **/Z** option

The power supply for driver's logic and communication must be appropriately stabilized or rectified and filtered: apply at least a 10000  $\mu\text{F}/40\text{ V}$  capacitance to single phase rectifiers or a 4700  $\mu\text{F}/40\text{ V}$  capacitance to three phase rectifiers.

The separate power supply for driver's logic on pin 9 and 10, allow to remove solenoid power supply from pin 1 and 2 maintaining active the diagnostics, USB and fieldbus communications.



A safety fuse is required in series to each driver's logic and communication power supply: 500 mA fast fuse.

### 17.3 Flow reference input signal (Q\_INPUT+)

The driver controls in closed loop the valve spool position proportionally to the external reference input signal.

Reference input signal is factory preset according to selected valve code, defaults are  $\pm 10\text{ VDC}$  for standard and  $4 \div 20\text{ mA}$  for **/I** option.

Input signal can be reconfigured via software selecting between voltage and current, within a maximum range of  $\pm 10\text{ VDC}$  or  $\pm 20\text{ mA}$ .

Drivers with fieldbus interface can be software set to receive reference signal directly from the machine control unit (fieldbus reference).

Analog reference input signal can be used as on-off commands with input range  $0 \div 24\text{VDC}$ .

### 17.4 Flow monitor output signal (Q\_MONITOR) - not for **/F**

The driver generates an analog output signal proportional to the actual spool position of the valve; the monitor output signal can be software set to show other signals available in the driver (e.g. analog reference, fieldbus reference, pilot spool position).

Monitor output signal is factory preset according to selected valve code, defaults are  $\pm 10\text{ VDC}$  for standard and  $4 \div 20\text{ mA}$  for **/I** option.

Output signal can be reconfigured via software selecting between voltage and current, within a maximum range of  $\pm 10\text{ VDC}$  or  $\pm 20\text{ mA}$ .

### 17.5 Enable input signal (ENABLE) - not for standard and **/F**

To enable the driver, supply a 24 VDC on pin 3 (pin C): Enable input signal allows to enable/disable the current supply to the solenoid, without removing the electrical power supply to the driver; it is used to active the communication and the other driver functions when the valve must be disabled for safety reasons. This condition **does not comply** with norms IEC 61508 and ISO 13849.

Enable input signal can be used as generic digital input by software selection.

### 17.6 Repeat enable output signal (R\_ENABLE) - only for **TEB-SN-NP** with **/Z** option

Repeat enable is used as output repeater signal of enable input signal (see 17.5).

### 17.7 Fault output signal (FAULT) - not for standard and **/Q**

Fault output signal indicates fault conditions of the driver (solenoid short circuits/not connected, reference signal cable broken for  $4 \div 20\text{ mA}$  input, spool position transducer cable broken, etc.). Fault presence corresponds to 0 VDC, normal working corresponds to 24 VDC.

Fault status is not affected by the Enable input signal. Fault output signal can be used as digital output by software selection.

## 18 IO-LINK SIGNALS SPECIFICATIONS - only for **TEB-SN-IL**

### 18.1 Power supply for IO-Link communication (L+ and L-)

The IO-Link master provides dedicated 24 Vdc power supply for IO-Link communication.

Maximum power consumption: 2 W

Internal electrical isolation of power L+, L- from P24, N24

### 18.2 Power supply for driver's logic and valve regulation (P24 and N24)

The IO-Link master provides dedicated 24 Vdc power supply for valve regulation, logics and diagnostics.

Maximum power consumption: 50 W

Internal electrical isolation of power P24, N24 from L+, L-

### 18.3 IO-Link data line (C/Q)

C/Q signal is used to establish communication between IO-Link master and valve.

## 19 ELECTRONIC CONNECTIONS AND LEDS

### 19.1 Main connector signals - 7 pin - standard, /F and /Q options (A1)

PIN	Standard	/Q	/F	TECHNICAL SPECIFICATIONS	NOTES
A	V+			Power supply 24 Vdc	Input - power supply
B	V0			Power supply 0 Vdc	Gnd - power supply
C	AGND		AGND	Analog ground	Gnd - analog signal
		ENABLE		Enable (24 Vdc) or disable (0 Vdc) the valve, referred to V0	Input - on/off signal
D	Q_INPUT+			Flow reference input signal: $\pm 10$ Vdc / $\pm 20$ mA maximum range Defaults are $\pm 10$ Vdc for standard and $4 \div 20$ mA for /I option	Input - analog signal <b>Software selectable</b>
E	INPUT-			Negative reference input signal for Q_INPUT+	Input - analog signal
F	Q_MONITOR referred to:			Flow monitor output signal: $\pm 10$ Vdc / $\pm 20$ mA maximum range Defaults are $\pm 10$ Vdc for standard and $4 \div 20$ mA for /I option	Output - analog signal <b>Software selectable</b>
	AGND	V0			
			FAULT	Fault (0 Vdc) or normal working (24 Vdc)	Output - on/off signal
G	EARTH			Internally connected to the driver housing	

### 19.2 Main connector signal - 12 pin - /Z option (A2)

PIN	TEB /Z	TES /Z	TECHNICAL SPECIFICATIONS	NOTES
1	V+		Power supply 24 Vdc	Input - power supply
2	V0		Power supply 0 Vdc	Gnd - power supply
3	ENABLE referred to:		Enable (24 Vdc) or disable (0 Vdc) the valve	Input - on/off signal
	V0	VL0		
4	Q_INPUT+		Flow reference input signal: $\pm 10$ Vdc / $\pm 20$ mA maximum range Defaults are $\pm 10$ Vdc for standard and $4 \div 20$ mA for /I option	Input - analog signal <b>Software selectable</b>
5	INPUT-		Negative reference input signal for Q_INPUT+	Input - analog signal
6	Q_MONITOR referred to:		Flow monitor output signal: $\pm 10$ Vdc / $\pm 20$ mA maximum range Defaults are $\pm 10$ Vdc for standard and $4 \div 20$ mA for /I option	Input - analog signal <b>Software selectable</b>
	AGND	VL0		
7	AGND		Analog ground	Output - analog signal
		NC	Do not connect	Gnd - analog signal
8	R_ENABLE		Repeat enable, output repeater signal of enable input, referred to V0	Output - on/off signal
		NC	Do not connect	
9	NC		Do not connect	
		VL+	Power supply 24 Vdc for driver's logic and communication	Input - power supply
10	NC		Do not connect	
		VL0	Power supply 0 Vdc for driver's logic and communication	Gnd - power supply
11	FAULT referred to:		Fault (0 Vdc) or normal working (24 Vdc)	Output - on/off signal
	V0	VL0		
PE	EARTH		Internally connected to the driver housing	

**Note:** do not disconnect VL0 before VL+ when the driver is connected to PC USB port

### 19.3 IO-Link connector signals - M12 - 5 pin - Coding A, port class B (A) only for TEB-SN-IL

PIN	SIGNAL	TECHNICAL SPECIFICATIONS	NOTES
1	L+	Power supply 24 Vdc for IO-Link communication	Input - power supply
2	P24	Power supply 24 Vdc for valve regulation, logics and diagnostics	Input - power supply
3	L-	Power supply 0 Vdc for IO-Link communication	Gnd - power supply
4	C/Q	IO-Link data line	Input / Output - signal
5	N24	Power supply 0 Vdc for valve regulation, logics and diagnostics	Gnd - power supply

**Note:** L+, L- and P24, N24 are electrically isolated

### 19.4 Communications connectors (B) - (C)

(B) USB connector - M12 - 5 pin always present		
PIN	SIGNAL	TECHNICAL SPECIFICATION (1)
1	+5V_USB	Power supply
2	ID	Identification
3	GND_USB	Signal zero data line
4	D-	Data line -
5	D+	Data line +

(C1) (C2) BC fieldbus execution, connector - M12 - 5 pin		
PIN	SIGNAL	TECHNICAL SPECIFICATION (1)
1	CAN_SHLD	Shield
2	not used	(C1) - (C2) pass-through connection (2)
3	CAN_GND	Signal zero data line
4	CAN_H	Bus line (high)
5	CAN_L	Bus line (low)

(C1) (C2) BP fieldbus execution, connector - M12 - 5 pin		
PIN	SIGNAL	TECHNICAL SPECIFICATION (1)
1	+5V	Termination supply signal
2	LINE-A	Bus line (high)
3	DGND	Data line and termination signal zero
4	LINE-B	Bus line (low)
5	SHIELD	

(C1) (C2) EH, EW, EI, EP fieldbus execution, connector - M12 - 4 pin		
PIN	SIGNAL	TECHNICAL SPECIFICATION (1)
1	TX+	Transmitter
2	RX+	Receiver
3	TX-	Transmitter
4	RX-	Receiver
Housing	SHIELD	

(1) shield connection on connector's housing is recommended

(2) Pin 2 can be fed with external +5V supply of CAN interface



19.5 TEB-SN-NP connections layout

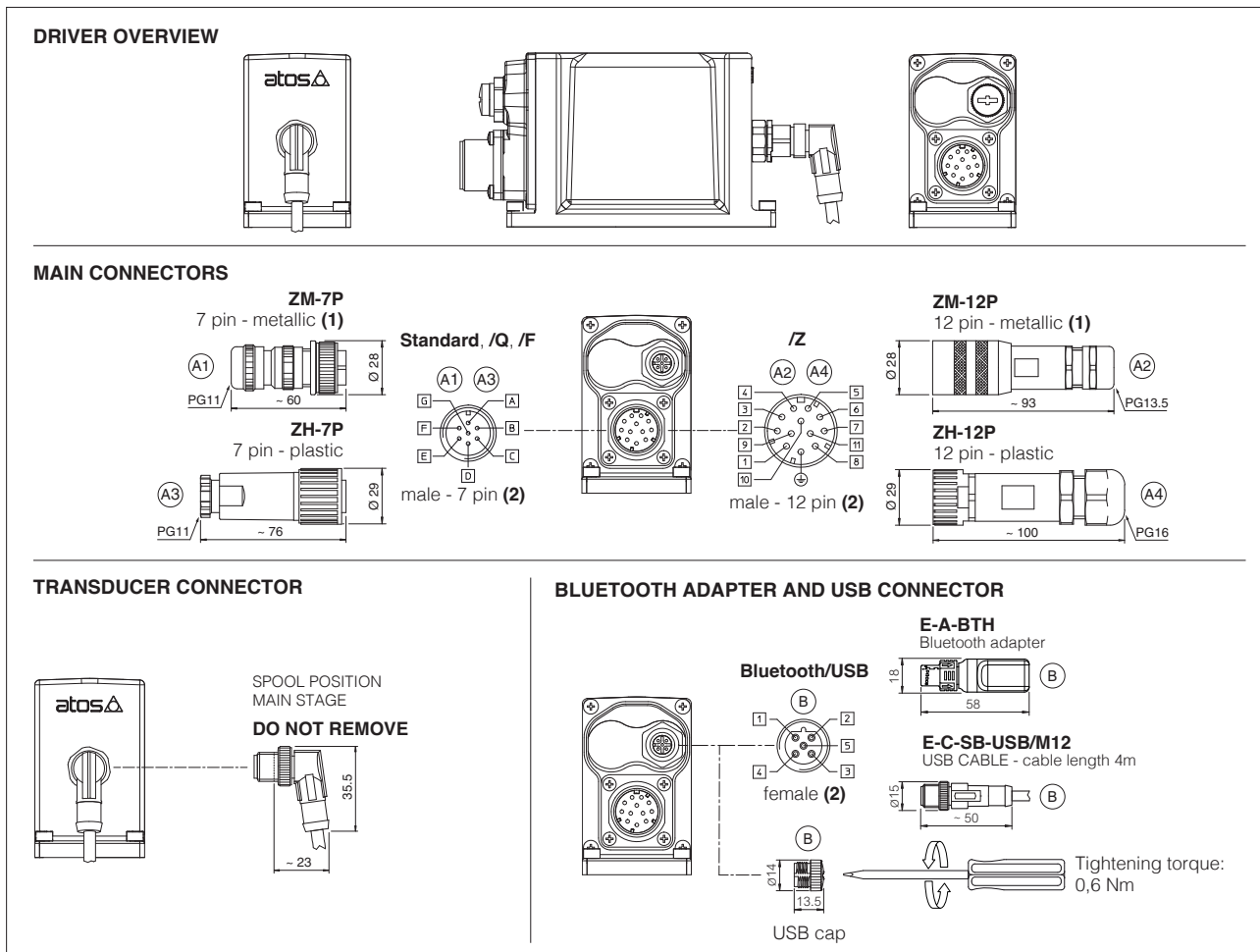

(1) Use of metallic connectors is strongly recommended in order to fulfill EMC requirements (2) Pin layout always referred to driver's view

19.6 TEB-SN-IL connections layout

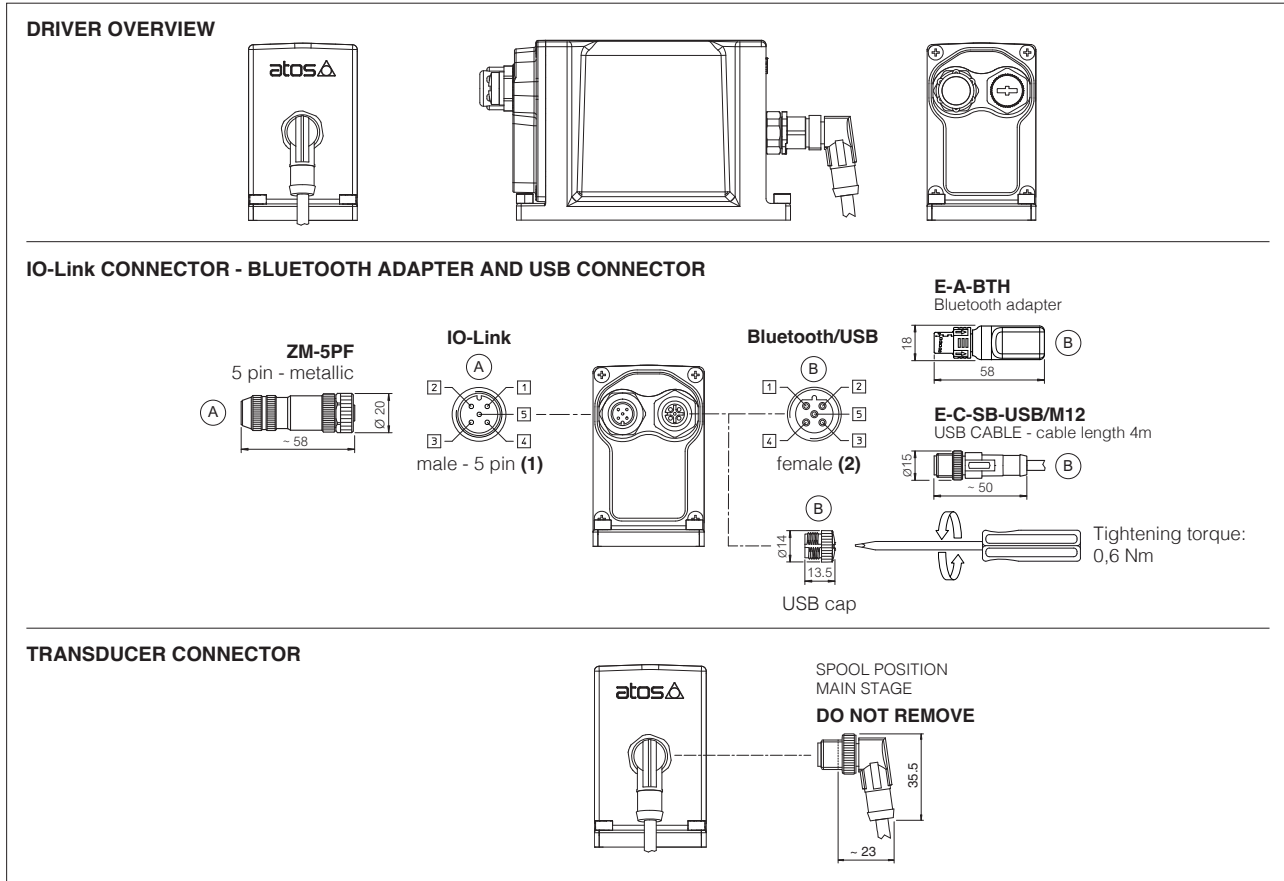

(1) Pin layout always referred to driver's view

## 19.7 TES connections layout

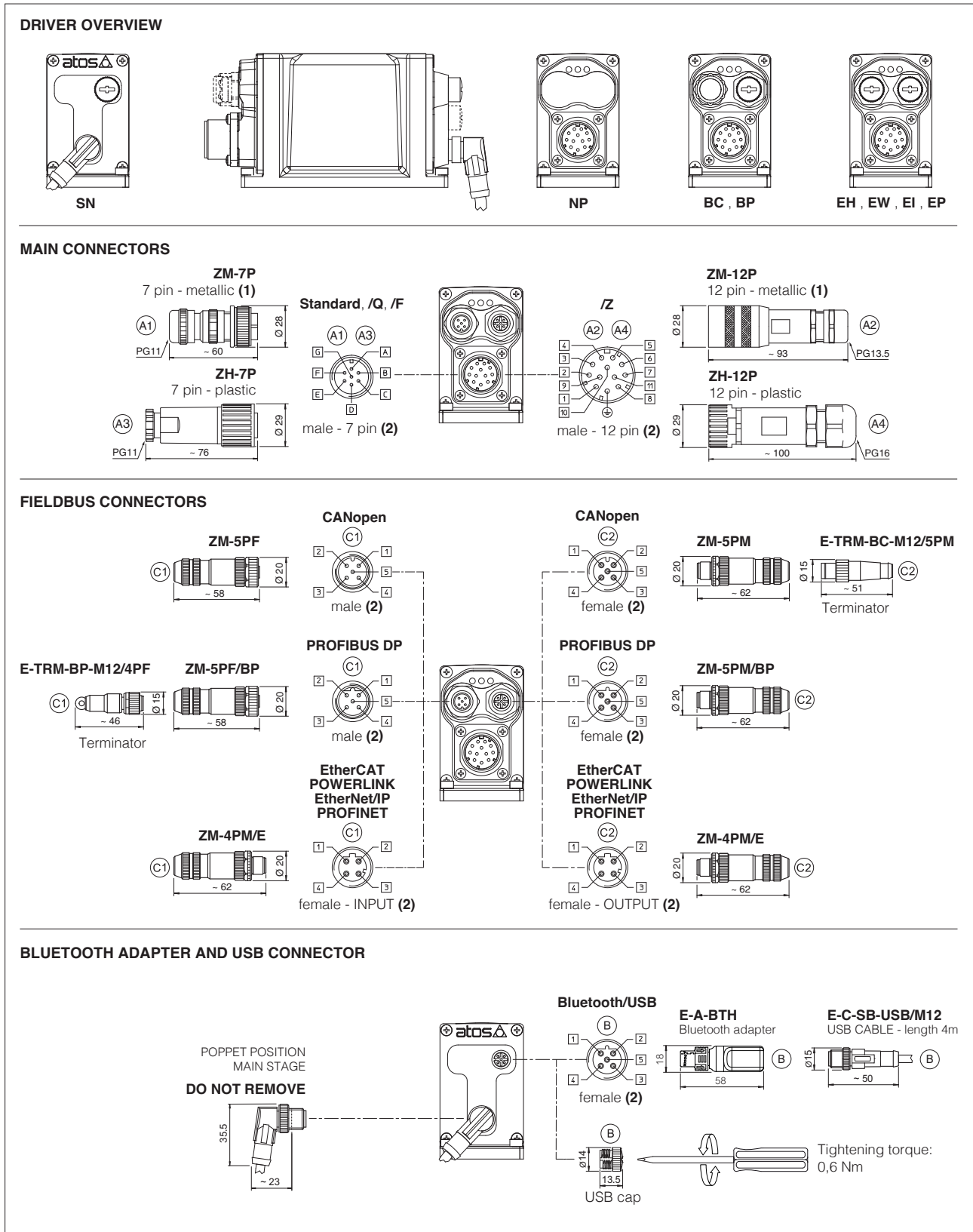

(1) Use of metallic connectors is strongly recommended in order to fulfill EMC requirements (2) Pin layout always referred to driver's view

## 19.8 Diagnostic LEDs - only for TES

Three leds show driver operative conditions for immediate basic diagnostics. Please refer to the driver user manual for detailed information.

FIELDBUS LEDS	NP Not Present	BC CANopen	BP PROFIBUS DP	EH EtherCAT	EW POWERLINK	EI EtherNet/IP	EP PROFINET	L1 L2 L3
L1		VALVE STATUS			LINK/ACT			
L2		NETWORK STATUS			NETWORK STATUS			
L3		SOLENOID STATUS			LINK/ACT			

## 20 IN / OUT FIELDBUS COMMUNICATION CONNECTORS

Two fieldbus communication connectors are always available for digital drivers executions BC, BP, EH, EW, EI, EP. This features allows considerable technical advantages in terms of installation simplicity, wirings reduction and also avoid the usage expensive T-connectors.

For BC and BP executions the fieldbus connectors have an internal pass-through connection and can be used like end point of the fieldbus network, using an external terminator (see tech table **GS500**).

For EH, EW, EI and EP executions the external terminators are not required: each connector is internally terminated.

### BC and BP pass-through connection

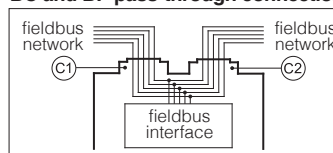

## 21 CONNECTORS CHARACTERISTICS - to be ordered separately

### 21.1 Main connectors - 7 pin

CONNECTOR TYPE	POWER SUPPLY AND SIGNALS	POWER SUPPLY AND SIGNALS
<b>CODE</b>	<b>(A1) ZM-7P</b>	<b>(A3) ZH-7P</b>
Type	7pin female straight circular	7pin female straight circular
Standard	According to MIL-C-5015	According to MIL-C-5015
Material	Metallic	Plastic reinforced with fiber glass
Cable gland	PG11	PG11
Recommended cable	LiYCY 7 x 0,75 mm <sup>2</sup> max 20 m (logic and power supply) or LiYCY 7 x 1 mm <sup>2</sup> max 40 m (logic and power supply)	LiYCY 7 x 0,75 mm <sup>2</sup> max 20 m (logic and power supply) or LiYCY 7 x 1 mm <sup>2</sup> max 40 m (logic and power supply)
Conductor size	up to 1 mm <sup>2</sup> - available for 7 wires	up to 1 mm <sup>2</sup> - available for 7 wires
Connection type	to solder	to solder
Protection (EN 60529)	IP 67	IP 67

### 21.2 Main connectors - 12 pin

CONNECTOR TYPE	POWER SUPPLY AND SIGNALS	POWER SUPPLY AND SIGNALS
<b>CODE</b>	<b>(A2) ZM-12P</b>	<b>(A4) ZH-12P</b>
Type	12pin female straight circular	12pin female straight circular
Standard	DIN 43651	DIN 43651
Material	Metallic	Plastic reinforced with fiber glass
Cable gland	PG13,5	PG16
Recommended cable	LiYCY 12 x 0,75 mm <sup>2</sup> max 20 m (logic and power supply)	LiYCY 10 x 0,14mm <sup>2</sup> max 40 m (logic) LiYY 3 x 1mm <sup>2</sup> max 40 m (power supply)
Conductor size	0,5 mm <sup>2</sup> to 1,5 mm <sup>2</sup> - available for 12 wires	0,14 mm <sup>2</sup> to 0,5 mm <sup>2</sup> - available for 9 wires 0,5 mm <sup>2</sup> to 1,5 mm <sup>2</sup> - available for 3 wires
Connection type	to crimp	to crimp
Protection (EN 60529)	IP 67	IP 67

### 21.3 IO-Link connector - only for TEB-SN-IL

CONNECTOR TYPE	IL IO-Link
<b>CODE</b>	<b>(A) ZM-5PF</b>
Type	5pin female straight circular
Standard	M12 coding A – IEC 61076-2-101
Material	Metallic
Cable gland	Pressure nut - cable diameter 6÷8 mm
Recommended cable	5 x 0,75 mm <sup>2</sup> max 20 m
Connection type	screw terminal
Protection (EN 60529)	IP 67

### 21.4 Fieldbus communication connectors

CONNECTOR TYPE	BC CANopen (1)		BP PROFIBUS DP (1)		EH EtherCAT, EW POWERLINK, EI EtherNet/IP, EP PROFINET (2)
	<b>(C1) ZM-5PF</b>	<b>(C2) ZM-5PM</b>	<b>(C1) ZM-5PF/BP</b>	<b>(C2) ZM-5PM/BP</b>	<b>(C1) (C2) ZM-4PM/E</b>
Type	5 pin female straight circular	5 pin male straight circular	5 pin female straight circular	5 pin male straight circular	4 pin male straight circular
Standard	M12 coding A – IEC 61076-2-101		M12 coding B – IEC 61076-2-101		M12 coding D – IEC 61076-2-101
Material	Metallic		Metallic		Metallic
Cable gland	Pressure nut - cable diameter 6÷8 mm		Pressure nut - cable diameter 6÷8 mm		Pressure nut - cable diameter 4÷8 mm
Cable	CANbus Standard (DR 303-1)		PROFIBUS DP Standard		Ethernet standard CAT-5
Connection type	screw terminal		screw terminal		terminal block
Protection (EN 60529)	IP67		IP 67		IP 67

(1) E-TRM-\*\* terminators can be ordered separately - see tech table **GS500**

(2) Internally terminated

## 22 PLUGS LOCATION FOR PILOT/DRAIN CHANNELS

Depending on the position of internal plugs, different pilot/drain configurations can be obtained as shown below.  
To modify the pilot/drain configuration, proper plugs must only be interchanged. The plugs have to be sealed using loctite 270.  
Standard valves configuration provides internal pilot and external drain

DPZO-1	Pilot channels	Drain channels	<p><b>Internal piloting:</b> blinded plug SP-X300F ① in X;  <b>External piloting:</b> blinded plug SP-X300F ② in Pp;  <b>Internal drain:</b> blinded plug SP-X300F ③ in Y;  <b>External drain:</b> blinded plug SP-X300F ④ in Dr.</p>
DPZO-2	Pilot channels	Drain channels	<p><b>Internal piloting:</b> Without blinded plug SP-X300F ①;  <b>External piloting:</b> Add blinded plug SP-X300F ①;  <b>Internal drain:</b> Without blinded plug SP-X300F ②;  <b>External drain:</b> Add blinded plug SP-X300F ②.</p>
DPZO-4	Pilot channels	Drain channels	<p><b>Internal piloting:</b> Without blinded plug SP-X500F ①;  <b>External piloting:</b> Add blinded plug SP-X500F ①;  <b>Internal drain:</b> Without blinded plug SP-X300F ②;  <b>External drain:</b> Add blinded plug SP-X300F ②.</p>
DPZO-6	Pilot channels	Drain channels	<p><b>Internal piloting:</b> Without plug ①;  <b>External piloting:</b> Add DIN-908 M16x1,5 in pos ①;  <b>Internal drain:</b> Without blinded plug SP-X300F ③;  <b>External drain:</b> Add blinded plug SP-X300F ③.</p>

## 23 FASTENING BOLTS AND SEALS

Type	Size	Fastening bolts	Seals
DPZO	1 = 10	4 socket head screws M6x40 class 12.9 Tightening torque = 15 Nm	5 OR 2050 Diameter of ports A, B, P, T: $\varnothing$ 11 mm (max) 2 OR 108 Diameter of ports X, Y: $\varnothing$ = 5 mm (max)
	2 = 16	4 socket head screws M10x50 class 12.9 Tightening torque = 70 Nm 2 socket head screws M6x45 class 12.9 Tightening torque = 15 Nm	4 OR 130 Diameter of ports A, B, P, T: $\varnothing$ 20 mm (max) 2 OR 2043 Diameter of ports X, Y: $\varnothing$ = 7 mm (max)
	4 = 25	6 socket head screws M12x60 class 12.9 Tightening torque = 125 Nm	4 OR 4112 Diameter of ports A, B, P, T: $\varnothing$ 24 mm (max) 2 OR 3056 Diameter of ports X, Y: $\varnothing$ = 7 mm (max)
	6 = 32	6 socket head screws M20x80 class 12.9 Tightening torque = 600 Nm	4 OR 144 Diameter of ports A, B, P, T: $\varnothing$ 34 mm (max) 2 OR 3056 Diameter of ports X, Y: $\varnothing$ = 7 mm (max)

24 INSTALLATION DIMENSIONS [mm]

ISO 4401: 2005  
 Mounting surface: 4401-05-05-0-05  
 (see table P005)

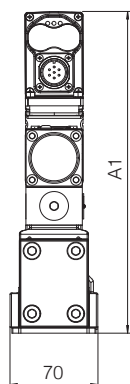

**DPZO-TEB-\*-15**  
**DPZO-TES-\*-15**

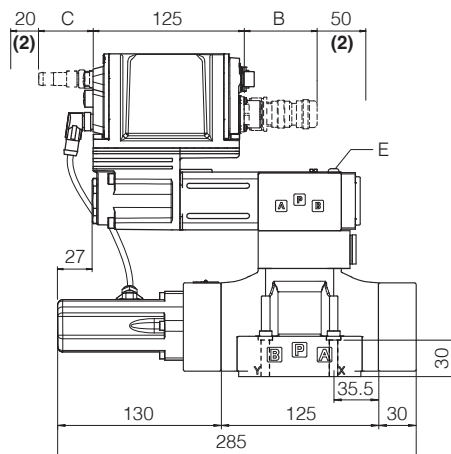

**DPZO-TEB-\*-17**  
**DPZO-TES-\*-17**

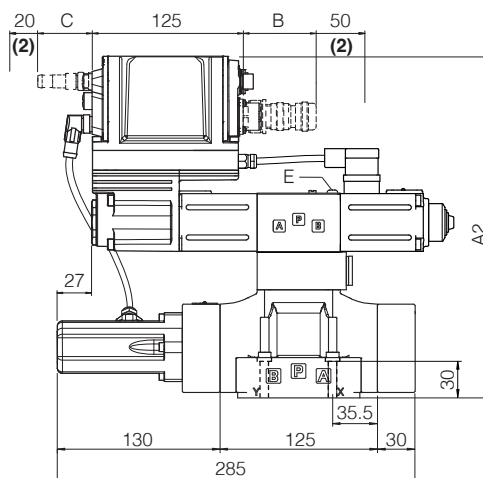

DPZO-*-1	A1	A2	B (1)	C (1)	E (air bleeding)	Mass [kg]	
TEB - SN - IL	256	271	60	-		DPZO-*-15	DPZO-*-17
TEB - SN - NP	256	271	100	-		9,8	10,5
TES - SN - NP, BC, BP, EH	256	271	100	58			
TES - SN - EW, EI, EP	271	271	100	58			

(1) The indicated dimension refers to the longer connectors or Bluetooth adapter  
 For dimensions of connectors and Bluetooth adapter, see sections 19.5, 19.6 and 19.7  
 (2) Space required for connection cable and for connector removal

**Note:** for /B option the proportional solenoid, the LVDT transducer and the on-board digital driver are at side of port A of the main stage

ISO 4401: 2005  
 Mounting surface: 4401-07-07-0-05  
 (see table P005)

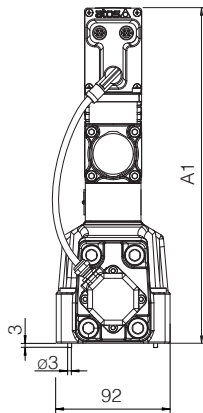

**DPZO-TEB\*-25**  
**DPZO-TES\*-25**

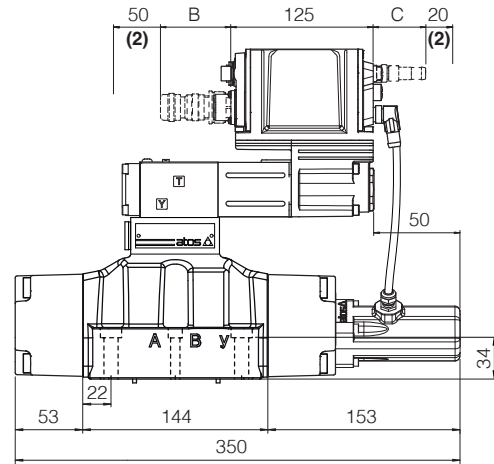

**DPZO-TEB\*-27**  
**DPZO-TES\*-27**

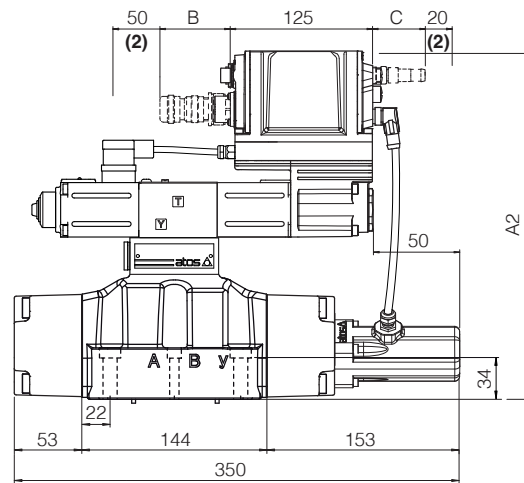

DPZO*-2	A1	A2	B (1)	C (1)	E (air bleeding)	Mass [kg]	
TEB - SN - IL	237	252	60	-		DPZO*-25	DPZO*-27
TEB - SN - NP	237	252	100	-		14,4	15,1
TES - SN - NP, BC, BP, EH	237	252	100	58			
TES - SN - EW, EI, EP	252	252	100	58			

(1) The indicated dimension refers to the longer connectors or Bluetooth adapter  
 For dimensions of connectors and Bluetooth adapter, see sections 19.5, 19.6 and 19.7  
 (2) Space required for connection cable and for connector removal

**Note:** for /B option the proportional solenoid, the LVDT transducer and the on-board digital driver are at side of port A of the main stage

ISO 4401: 2005  
 Mounting surface: 4401-08-08-0-05  
 (see table P005)

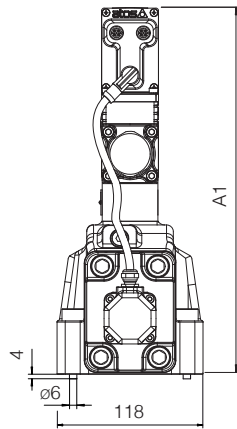

**DPZO-TEB\*-45**  
**DPZO-TES\*-45**

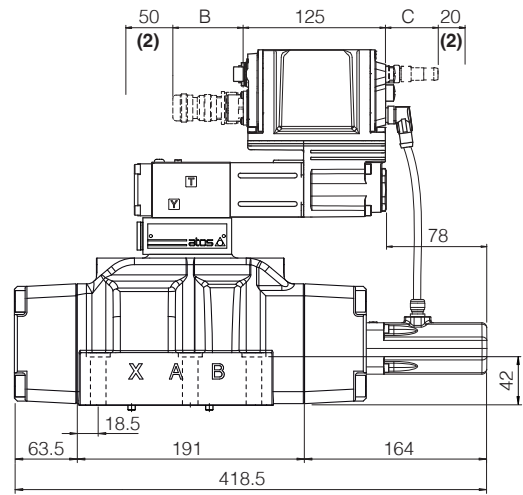

**DPZO-TEB\*-47**  
**DPZO-TES\*-47**

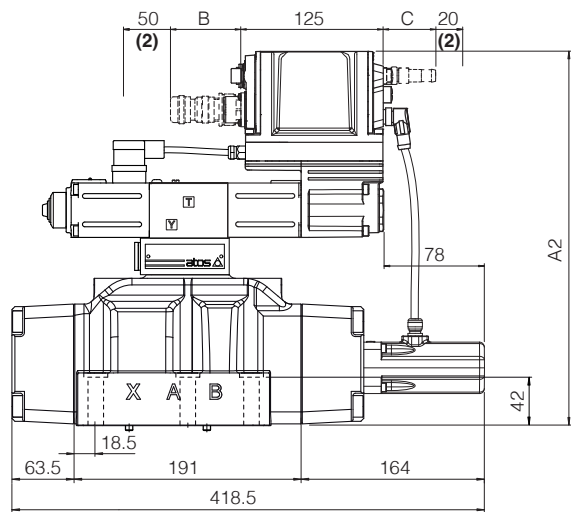

DPZO*-4	A1	A2	B (1)	C (1)	E (air bleeding)	Mass [kg]	
						DPZO*-45	DPZO*-47
TEB - SN - IL	266	281	60	-		18,9	19,6
TEB - SN - NP	266	281	100	-			
TES - SN - NP, BC, BP, EH	266	281	100	58			
TES - SN - EW, EI, EP	281	281	100	58			

(1) The indicated dimension refers to the longer connectors or Bluetooth adapter  
 For dimensions of connectors and Bluetooth adapter, see sections 19.5, 19.6 and 19.7  
 (2) Space required for connection cable and for connector removal

**Note:** for /B option the proportional solenoid, the LVDT transducer and the on-board digital driver are at side of port A of the main stage

ISO 4401: 2005  
 Mounting surface: 4401-10-09-0-05  
 (see table P005)

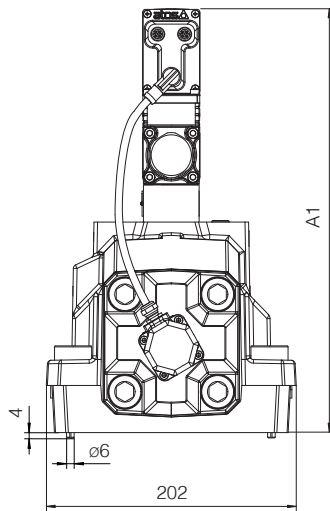

**DPZO-TEB-\*-65**  
**DPZO-TES-\*-65**

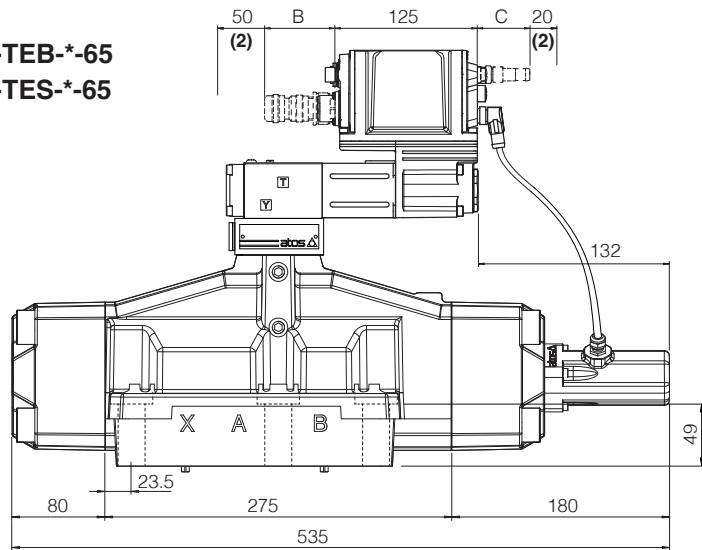

**DPZO-TEB-\*-67**  
**DPZO-TES-\*-67**

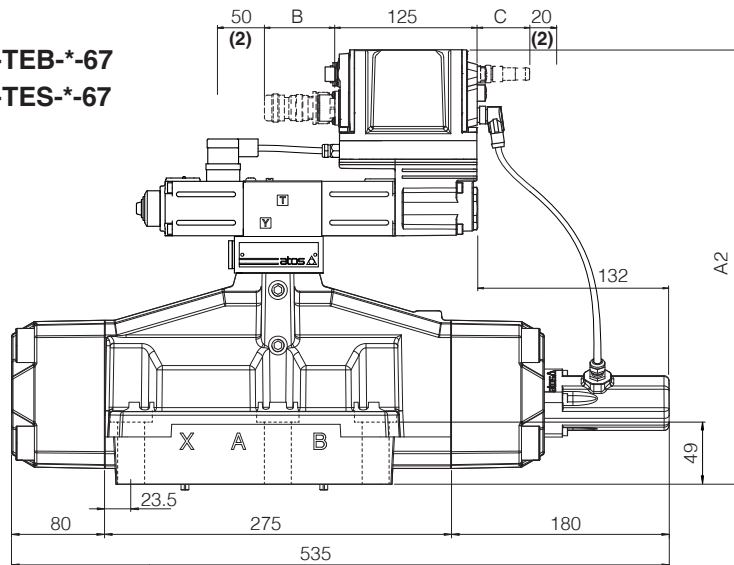

DPZO-*-6	A1	A2	B (1)	C (1)	E (air bleeding)	Mass [kg]	
TEB - SN - IL	308	323	60	-	3	DPZO-*-65	DPZO-*-67
TEB - SN - NP	308	323	100	-			
TES - SN - NP, BC, BP, EH	308	323	100	58		43,4	44,1
TES - SN - EW, EI, EP	323	323	100	58			

- (1) The indicated dimension refers to the longer connectors or Bluetooth adapter  
 For dimensions of connectors and Bluetooth adapter, see sections 19.5, 19.6 and 19.7  
 (2) Space required for connection cable and for connector removal

**Note:** for /B option the proportional solenoid, the LVDT transducer and the on-board digital driver are at side of port A of the main stage

**25 RELATED DOCUMENTATION**

<b>FS001</b>	Basics for digital electrohydraulics	<b>K800</b>	Electric and electronic connectors
<b>FS900</b>	Operating and maintenance information for proportional valves	<b>P005</b>	Mounting surfaces for electrohydraulic valves
<b>FY100</b>	Safety proportional valves - option /U	<b>QB320</b>	Quickstart for TEB valves commissioning
<b>FY200</b>	Safety proportional valves - option /K	<b>QF320</b>	Quickstart for TES valves commissioning
<b>GS500</b>	Programming tools	<b>Y010</b>	Basics for safety components
<b>GS510</b>	Fieldbus	<b>E-MAN-RI-LEB</b>	TEB/LEB user manual
<b>GS520</b>	IO-Link interface	<b>E-MAN-RI-LES</b>	TES/LES user manual