

# Precision Regulator

**New**  
RoHS

**Air consumption**

Reduced by **Up to approx. 90%**\*  
[l/min (ANR)]

Series	Current model	New IR
IR1000-A/IR2000-A	4.4	1 or less
IR3000-A	11.5	1 or less

\* Compared with the current IR1000/2000/3000

**High flow rate**

Up to approx. **twice**\*  
[l/min (ANR)]

Series	Current model	New IR
IR1000-A	320	720
IR2000-A	940	1900

\* Compared with the current IR1000/2000

**Lightweight**

Reduced by up to approx. **27%**\*  
[kg]

Series	Current model	New IR
IR1000-A	0.14	0.13
IR2000-A	0.30	0.23
IR3000-A	0.64	0.47

\* Compared with the current IR1000/2000/3000

**Sensitivity: 0.2%** (Full span)

**Repeatability: ±0.5%** (Full span)

## Space saving

New structure without fixed throttle does not require a mist separator.

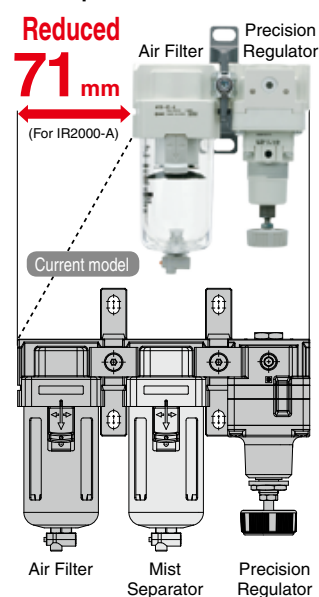

**Series IR1000-A/2000-A/3000-A**



CAT.EUS60-22A-UK

# Reduction in air consumption

## ● Air consumption is reduced with a new original structure.

With this new original structure, running costs are reduced.

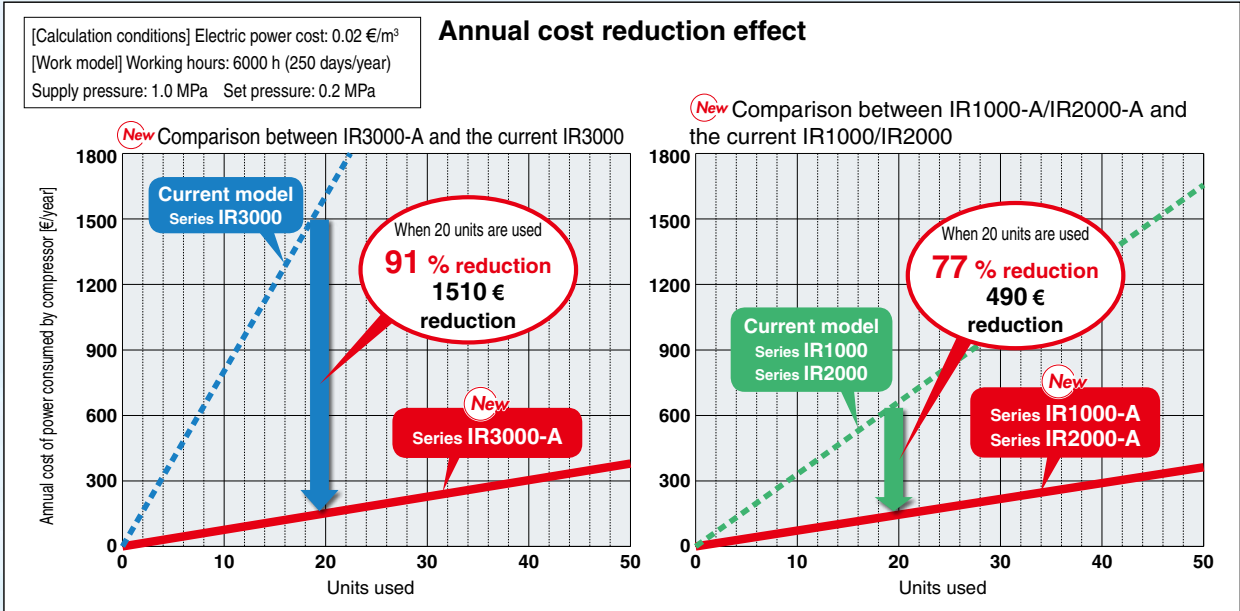

## ● No fixed throttle in the new design.

\* Poor quality of air may cause operation failure. Select a model for air quality that is suitable for the desired air cleanliness in catalogue on SMC website [www.smc.eu](http://www.smc.eu)

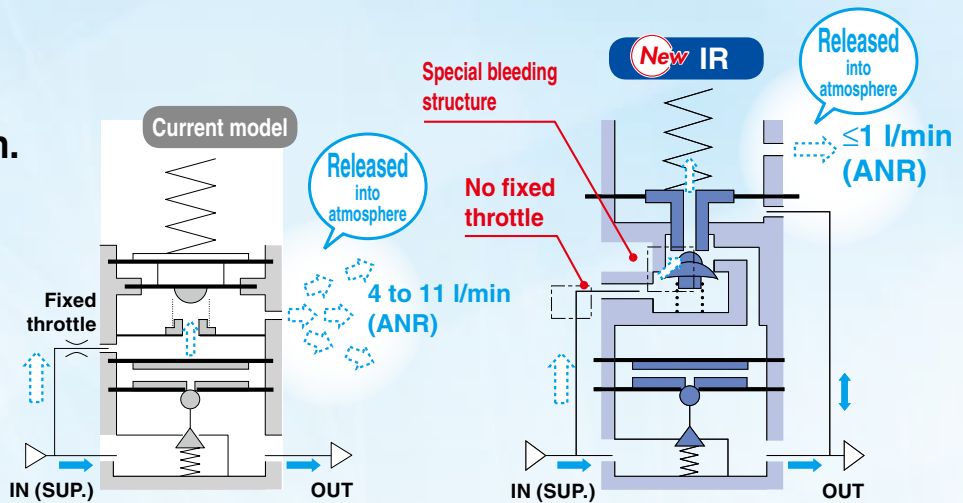

## ● Flow rate: Up to approx. twice

(Compared to the current SMC product) [l/min(ANR)]

Series	Current model	<b>New IR</b>
IR1000-A	320	<b>720</b>
IR2000-A	940	<b>1900</b>

Supply pressure: 0.7 MPa

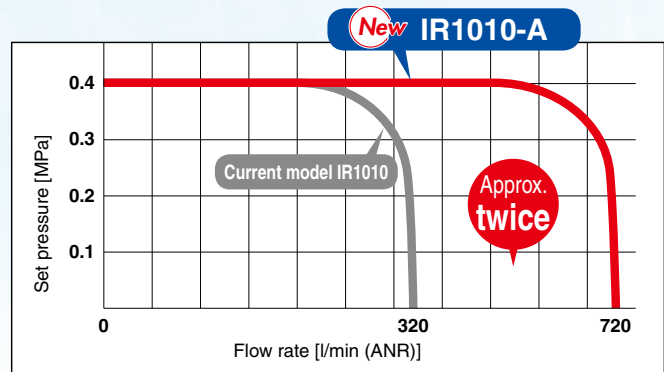

Supply pressure: 0.7 MPa

## Weight

Reduced by up to approx. **27%** [kg]

Series	Current model	<b>New IR</b>
IR1000-A	0.14	<b>0.13</b>
IR2000-A	0.30	<b>0.23</b>
IR3000-A	0.64	<b>0.47</b>



Digital pressure switch standardised



Pressure gauge

## Hexagon panel nut mounting

\* Interchangeable with the current SMC product

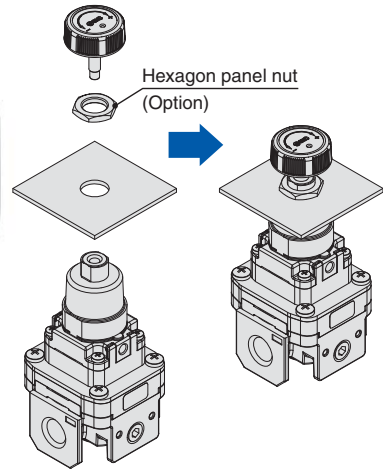

**Sensitivity: 0.2%** (Full span)

**Repeatability: ±0.5%** (Full span)

**Mounting is interchangeable with the current SMC model.**

## New IR can be used between a cylinder and solenoid valve.

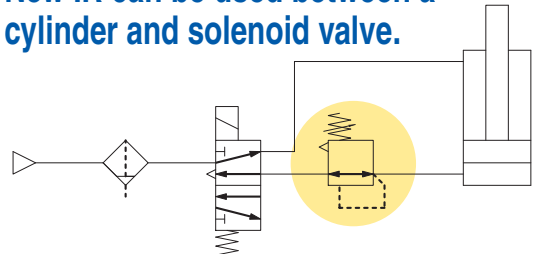

Note) The set pressure may vary depending on the elapsed time and change in ambient temperature after pressure setting. If the setting value varies, adjust the pressure with the knob.

## Exhaust (EXH) directions can be selected. (Series IR3000-A)

**New** Bottom and front exhaust added.

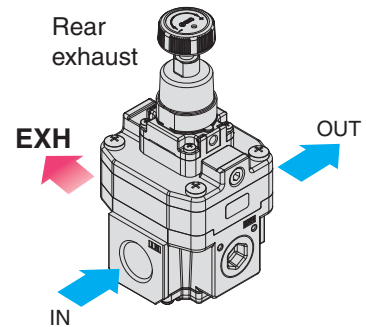
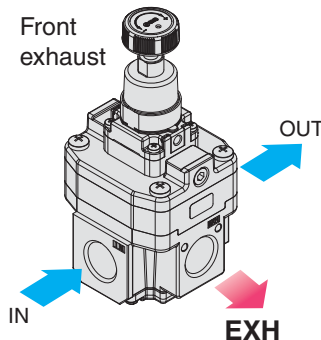
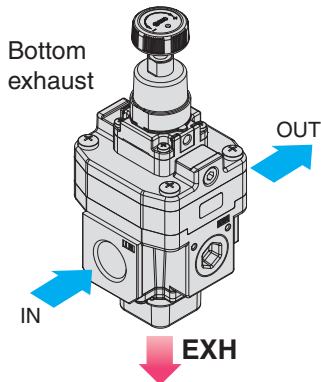

## Application Examples

### Constant fluid pressure

Note)

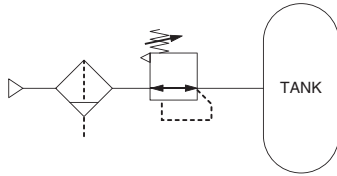

- As there is a large effective area for supply and exhaust pressure, setting can be done quickly.

### Balance and drive Accurate balance pressure setting

Note)

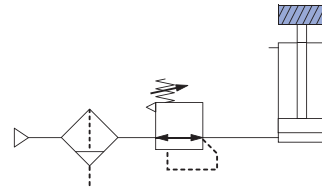

- Limits pressure fluctuation when driving a cylinder, maintaining excellent static and dynamic balance.

### Accurate pressure setting Sensitivity within 0.2 % F.S. (Full Span) Tension control

Note)

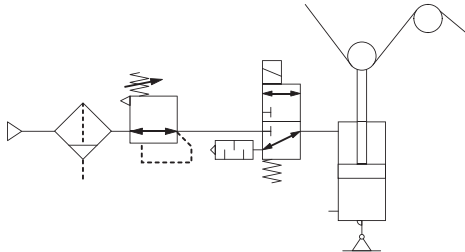

### Contact pressure control

Note)

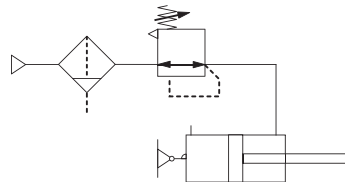

- Adapts to the cylinder's piston displacement, maintaining a constant pressure.

### Multistage control of pressing force for workpiece (Wrapping machine)

Note)

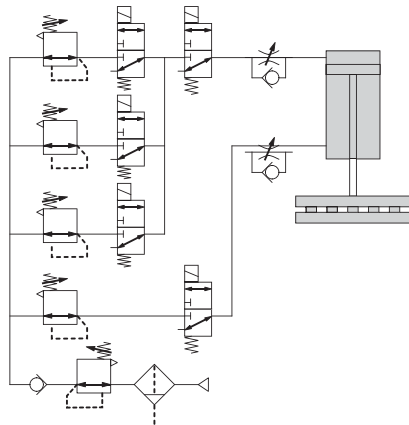

### Leak test circuit

Note)

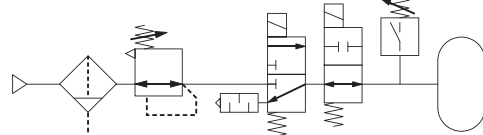

### Residual pressure relief

Note)

Ex.) Backflow from the tank

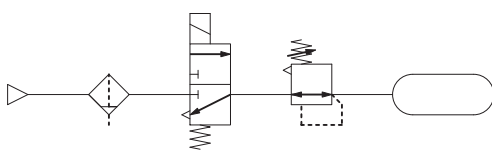

- Residual pressure is exhausted by relief function.

### Usage between a cylinder and solenoid valve

Note)

Ex.) Between a cylinder and solenoid valve

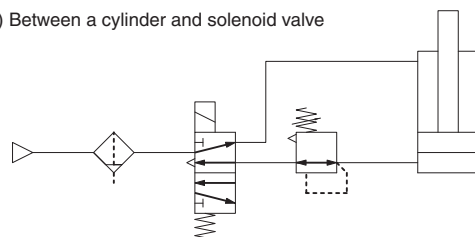

- It can be used between a cylinder and a solenoid valve.

**Adjustment of blow-line pressure** Note)

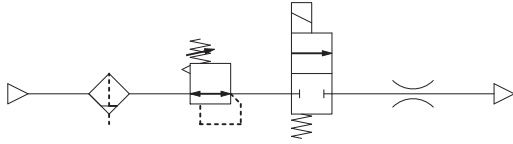

- Outlet pressure is less affected by fluctuation of inlet pressure. New IR offers consistent pressure control.

Note) The set pressure may vary depending on the elapsed time and change in ambient temperature after pressure setting. If the setting value varies, adjust the pressure with the knob.



**Series Variations**

	Series	Model	Set pressure range (MPa)	Port size
Basic Type (Knob)	 IR1000-A	IR1000-A	0.005 to 0.2	1/8
		IR1010-A	0.01 to 0.4	
		IR1020-A	0.01 to 0.8	
	 IR2000-A	IR2000-A	0.005 to 0.2	1/4
		IR2010-A	0.01 to 0.4	
		IR2020-A	0.01 to 0.8	
	 IR3000-A	IR3000-A	0.01 to 0.2	1/4, 3/8, 1/2
		IR3010-A	0.01 to 0.4	
		IR3020-A	0.01 to 0.8	

# Precision Regulator

RoHS

## Series IR1000-A/2000-A/3000-A

Symbol

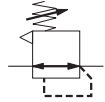

Basic type  
(Knob)

### Standard Specifications

Model	Basic type (Knob)		
	IR10□0-A	IR20□0-A	IR30□0-A
Fluid	Air		
Proof pressure	1.5 MPa		
Max. supply pressure	1.0 MPa		
Min. supply pressure <sup>Note 1)</sup>	Set pressure + 0.05 MPa		Set pressure + 0.1 MPa
Set pressure range	IR1000-A: 0.005 to 0.2 MPa	IR2000-A: 0.005 to 0.2 MPa	IR3000-A: 0.01 to 0.2 MPa
	IR1010-A: 0.01 to 0.4 MPa	IR2010-A: 0.01 to 0.4 MPa	IR3010-A: 0.01 to 0.4 MPa
	IR1020-A: 0.01 to 0.8 MPa	IR2020-A: 0.01 to 0.8 MPa	IR3020-A: 0.01 to 0.8 MPa
Sensitivity	Within 0.2 % of full span		
Repeatability <sup>Note 2)</sup>	Within ±0.5 % of full span		
Air consumption <sup>Note 3)</sup>	1 l/min (ANR) or less		
Port size	1/8	1/4	1/4, 3/8, 1/2
Pressure gauge port	1/8 (2 locations)		
Ambient and fluid temperature <sup>Note 4)</sup>	-5 to 60° C (No freezing)		
Weight [kg] <sup>Note 5)</sup>	0.13	0.23	0.47

Note 1) When there is no flow rate on the outlet.

Note 2) Other characteristics such as aging deterioration and temperature characteristics are not included.

Note 3) Measuring conditions: supply pressure 1.0 MPa, set pressure 0.2 MPa

Note 4) -5 to 50° C for the products with the digital pressure switch

Note 5) Without accessories

### Accessories (Option)/Part No.

Description	IR10□0-A	IR20□0-A	IR30□0-A
Bracket assembly <sup>Note 1)</sup>	IR10P-501AS	IR20P-501AS	IR30P-501AS
Hexagon panel nut	IR10P-600S	IR20P-600S	IR20P-600S
Round type pressure gauge <sup>Note 2)</sup>	0.2 MPa setting	G33-2-□01	G43-2-□01
	0.4 MPa setting	G33-4-□01	G43-4-□01
	0.8 MPa setting	G33-10-□01	G43-10-□01
Digital pressure switch <sup>Note 3)</sup>	NPN 1 output	ISE30A-□01-N-ML	
	PNP 1 output	ISE30A-□01-P-ML	
	NPN 1 output/ Voltage output	ISE30A-□01-C-ML	
	NPN 1 output/ Current output	ISE30A-□01-D-ML	

Note 1) This is an assembly of the bracket and resin panel nut.

Note 2) □ in part numbers for a round type pressure gauge indicates a type of connection thread. No indication is necessary for R; however, indicate N for NPT.

A 1.0 MPa pressure gauge is fitted for 0.8 MPa setting.

Please contact SMC regarding the supply of pressure gauge with psi unit specifications.

Note 3) □ in part numbers for a digital pressure switch indicates a type of connection thread. No indication is necessary for R; however, indicate N for NPT. For details on handling digital pressure switch and specifications, refer to the **WEB catalogue** on [www.smc.eu](http://www.smc.eu). Please contact SMC regarding the supply of digital pressure switch with unit conversion function.

### Modular Products and Accessories

Applicable products and accessories	Applicable size		
	Series IR1000-A	Series IR2000-A	Series IR3000-A
Filter	AF20-A	AF30-A	AF40-A
Spacer	Y200-A	Y300-A	Y400-A
Spacer with bracket	Y200T-A	Y300T-A	Y400T-A

Refer to the **WEB catalogue** for details of the modular applicable products and accessories. The former modular and mounting brackets can be used.

# Precision Regulator *Series IR1000-A/2000-A/3000-A*

## How to Order

IR 1 0 0 0 -   01 **BG** -   - **A**

1  
 2  
 3  
 4  
 5  
 6  
 7

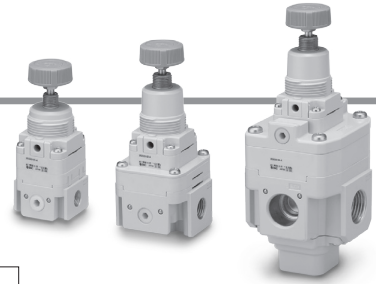

- Option/Semi-standard: Select one each for **a** to **f**. Options **b** and **c** cannot be selected together.
- Option/Semi-standard symbol: When more than one specification is required, indicate in alphanumeric order.

	Symbol	Description	①				
			Body size				
			1	2	3		
②	Set pressure range	0	0.005 to 0.2 MPa	●	●	—	
		1	0.01 to 0.2 MPa	—	—	●	
		2	0.01 to 0.4 MPa	●	●	●	
		2	0.01 to 0.8 MPa	●	●	●	
③	Exhaust direction	0	Bottom exhaust	●	●	●	
		1	Front exhaust	—	—	●	
		2	Rear exhaust	—	—	●	
④	Pipe thread type	—	Rc	●	●	●	
		N	NPT	●	●	●	
		F	G	●	●	●	
⑤	Port size	01	1/8	●	—	—	
		02	1/4	—	●	●	
		03	3/8	—	—	●	
		04	1/2	—	—	●	
⑥	a	Mounting	—	Without mounting option	●	●	●
			B <sup>Note 2)</sup>	With bracket	●	●	●
			H	With hexagon panel nut (for panel mount)	●	●	●
	b	Pressure gauge	—	Without pressure gauge	●	●	●
			G	Round type pressure gauge	●	●	●
	c	With digital pressure switch	EA	NPN open collector 1 output	●	●	●
			EB	PNP open collector 1 output	●	●	●
			EC	NPN open collector 1 output + Analogue voltage output	●	●	●
			ED	NPN open collector 1 output + Analogue current output	●	●	●
	⑦	d	Flow direction	—	Flow direction: Left to right	●	●
R				Flow direction: Right to left	●	●	●
e		Knob	—	Upward	●	●	●
			V	Downward	●	●	●
f		Pressure unit <sup>Note 3)</sup>	—	Name plate and pressure gauge in imperial units: MPa	●	●	●
			Z	Name plate and pressure gauge in imperial units: psi	●	●	●
	ZA		Digital pressure switch: With unit conversion function	●	●	●	

Note 1) Options are shipped together with the product, but not assembled. B and H cannot be selected at the same time. The current bracket cannot be used for this product.

Note 2) Assembly of a bracket and set nuts.

Note 3) See pressure unit table below.

	Pipe thread type	Name plate in imperial units	Pressure gauge in imperial units	
			G	EA, EB, EC, ED
—	Rc	MPa	MPa	Fixed SI unit
	NPT			
	G			
Z <sup>Note 4)</sup>	Rc	—	—	—
	NPT	psi	psi	With unit conversion function (Initial value psi)
	G	—	—	—
ZA <sup>Note 5)</sup>	Rc	MPa	—	With unit conversion function
	NPT			
	G			

Note 4) For pipe thread type: NPT

Note 5) For options: EA, EB, EC, ED

# Series IR1000-A/2000-A/3000-A

## Series IR1000-A

\* The data shown below are representative values, and are not guaranteed.

### Flow-rate Characteristics

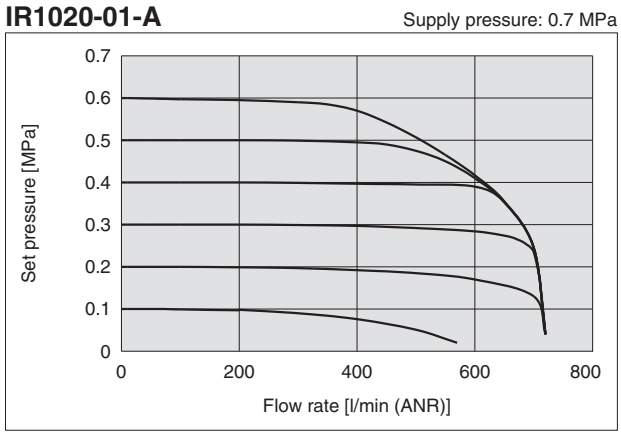

### Relief Characteristics

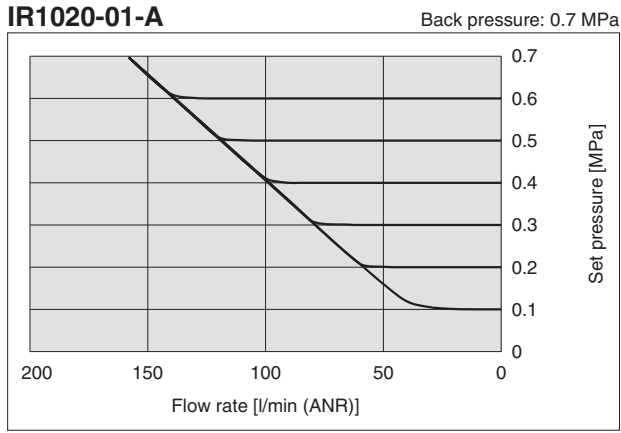

### Pressure Characteristics

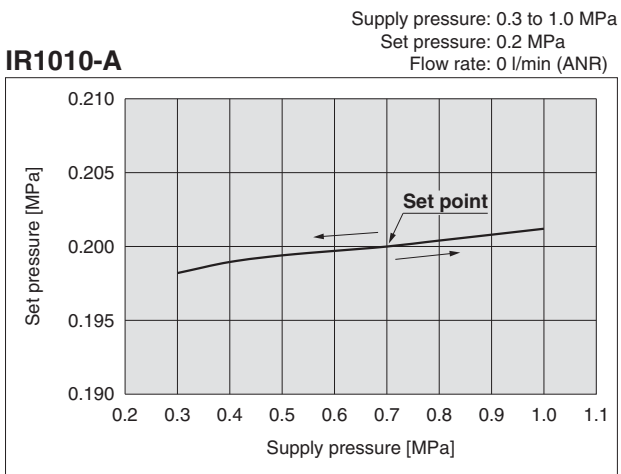
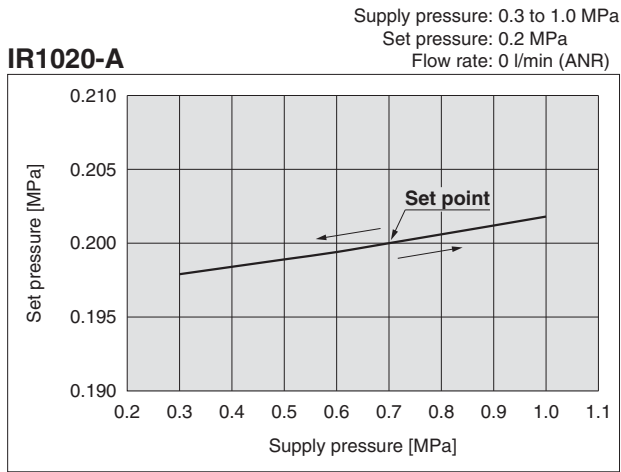
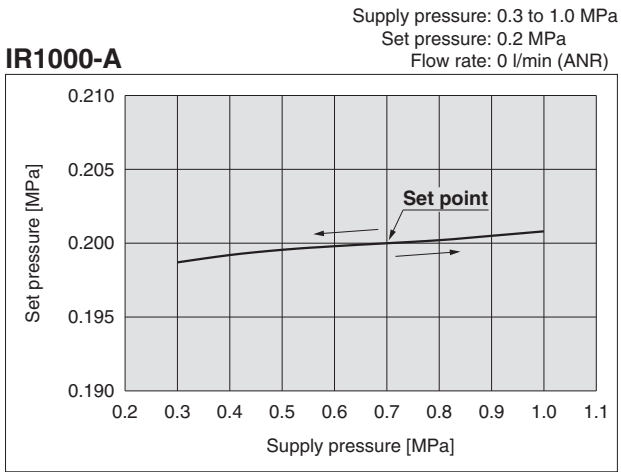



# Precision Regulator *Series IR1000-A/2000-A/3000-A*

## Series IR2000-A

\* The data shown below are representative values, and are not guaranteed.

### Flow-rate Characteristics

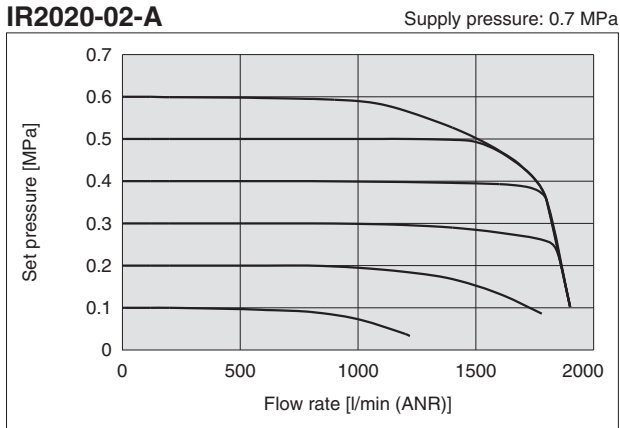

### Relief Characteristics

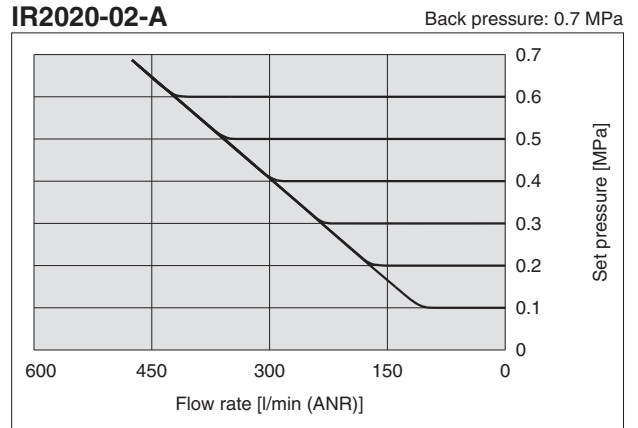

### Pressure Characteristics

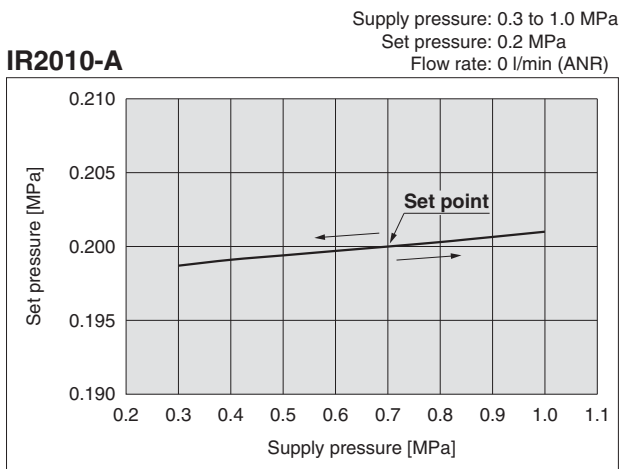
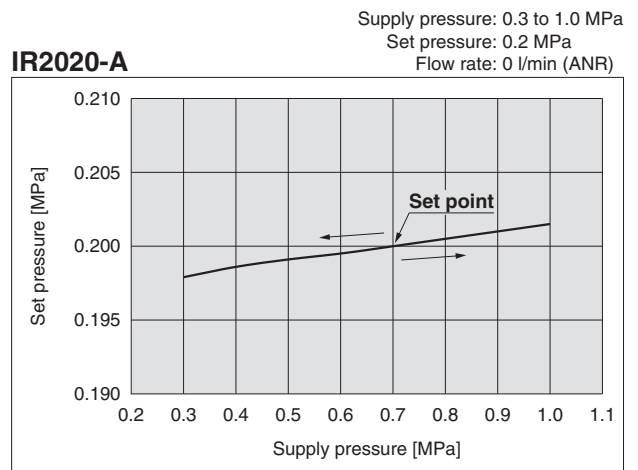
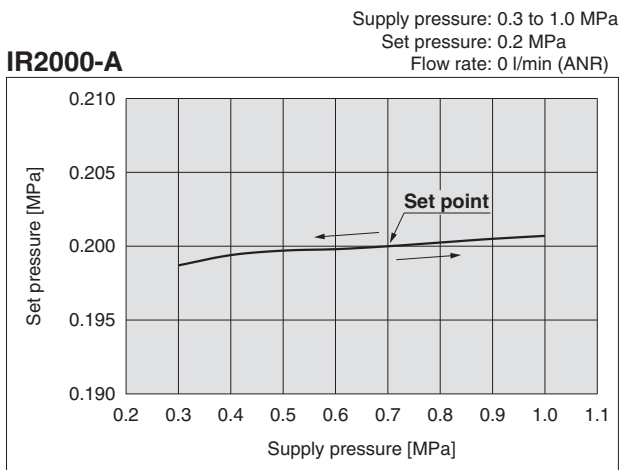

# Series IR1000-A/2000-A/3000-A

## Series IR3000-A

\* The data shown below are representative values, and are not guaranteed.

### Flow-rate Characteristics

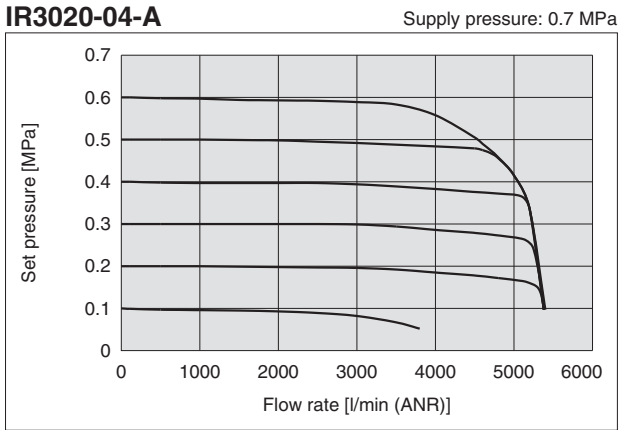

### Relief Characteristics

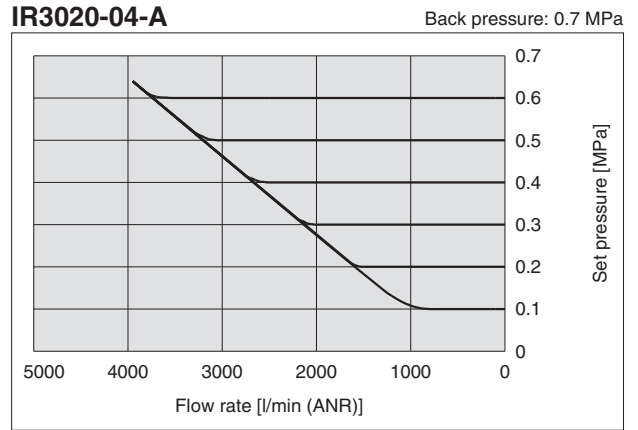

### Pressure Characteristics

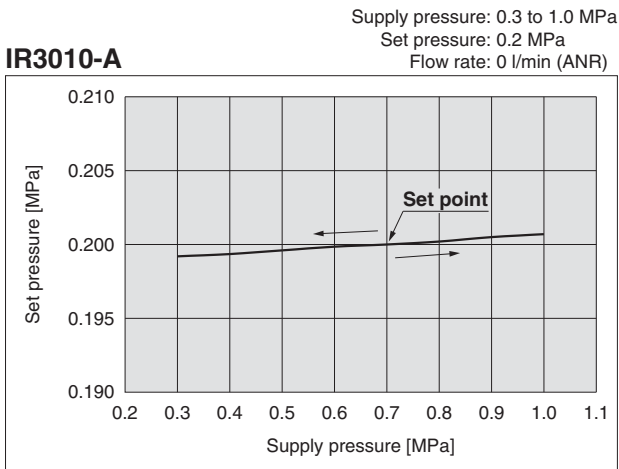
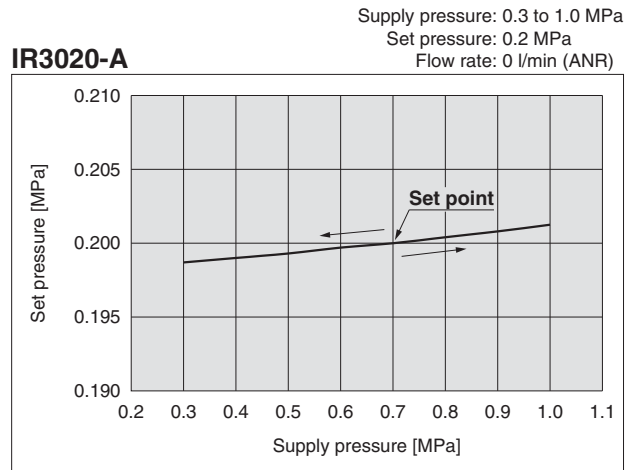
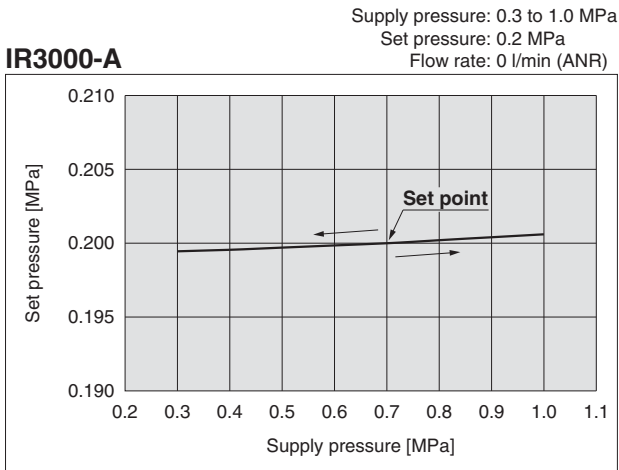

# Precision Regulator *Series IR1000-A/2000-A/3000-A*

## Construction

### Basic type (Knob): IR20□0-A

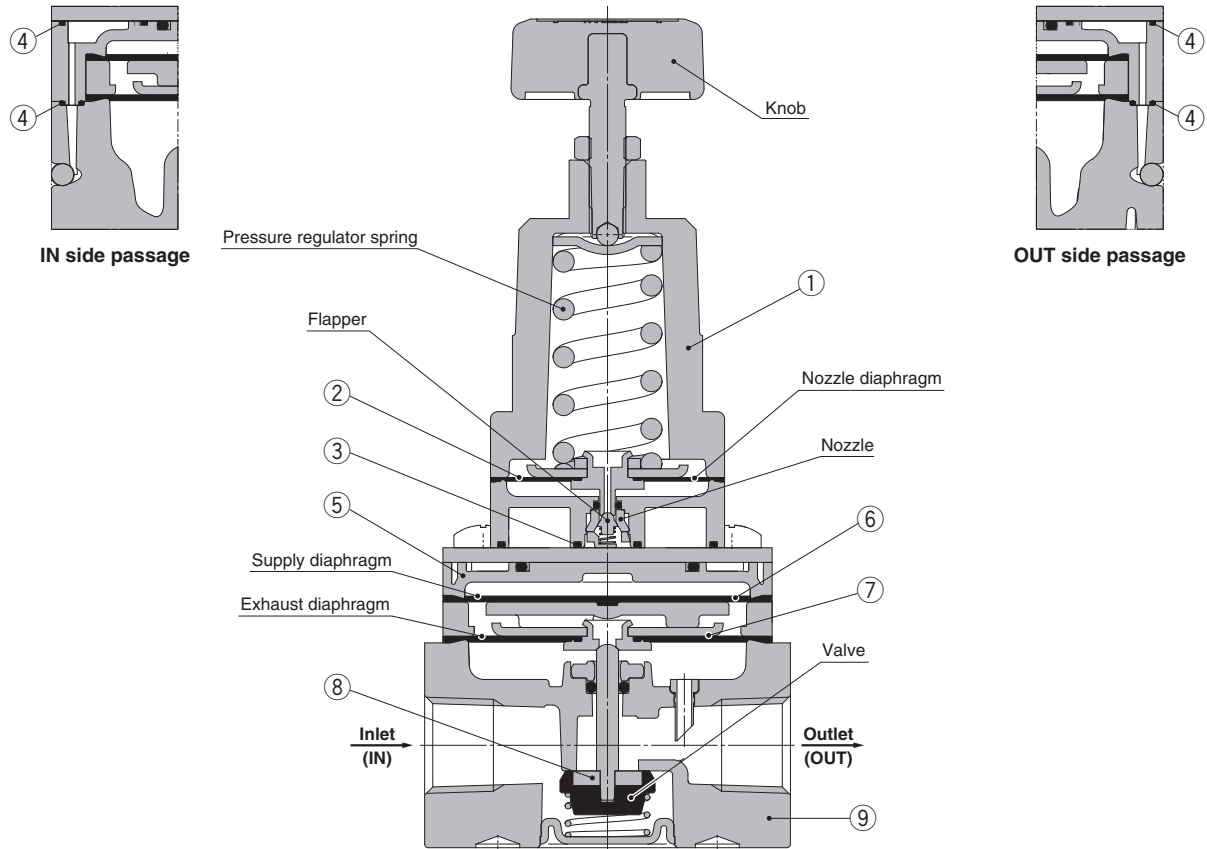

### Working principle

When the knob is rotated, the flapper is pushed through the spring, and a gap is generated between the nozzle and flapper. The supply pressure flows to the inlet passes through the path between the nozzle and flapper and acts on the supply diaphragm as nozzle back pressure. The force generated by the diaphragm pushes down the valve, and the supply pressure flows to the outlet. The discharged air pressure acts on the exhaust diaphragm, and counteracts against the force generated by the supply diaphragm. The air pressure acts on the nozzle diaphragm at the same time, and counteracts against the compression force of the spring to adjust the set pressure. When the set pressure increases too much, the nozzle diaphragm is pushed up, and a gap is generated between the flapper and nozzle diaphragm after the flapper is closed. The balance of the supply diaphragm and exhaust diaphragm is lost when the nozzle back pressure flows into the atmosphere. The exhaust valve is open after the valve is closed, and excess pressure on the outlet is released to the air. Due to this pilot mechanism, fine pressure variations are detected and precise pressure adjustment is possible.

### Component Parts

No.	Description	Material		
		IR1000-A	IR2000-A	IR3000-A
1	Bonnet	Aluminium die-casted		
2	Nozzle diaphragm assembly	Aluminium, Weather resistant NBR		
3	Seal	HNBR		
4	Seal	NBR		
5	Diaphragm spacer	Polyacetal		
6	Supply diaphragm	Weather resistant NBR		—
7	Exhaust diaphragm assembly	Steel, Aluminium, Weather resistant NBR		Aluminium, Weather resistant NBR, HNBR
8	Valve assembly	Stainless steel, Aluminium, HNBR		Aluminium, HNBR
9	Body	Aluminium die-casted		

# Series IR1000-A/2000-A/3000-A

## Construction

### Basic type (Knob): IR10□0-A

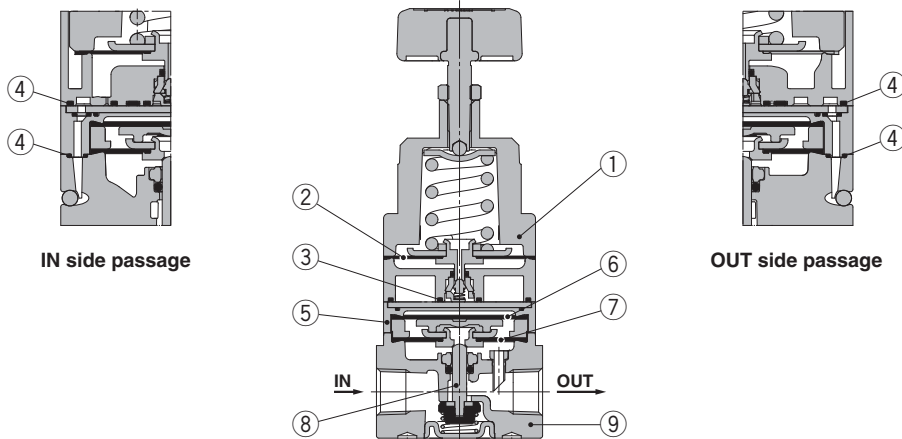

### Basic type (Knob): IR30□0-A

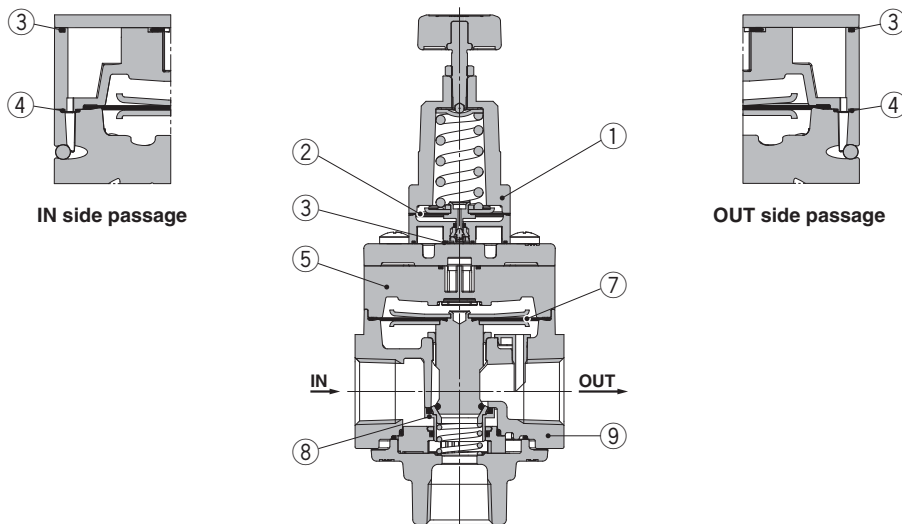

### Basic type (Knob): IR30□ $\frac{1}{2}$ -A

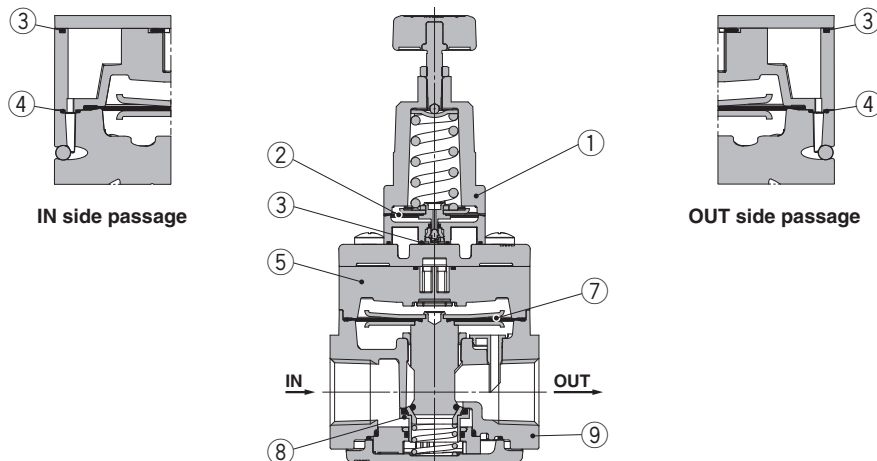

# Precision Regulator *Series IR1000-A/2000-A/3000-A*

## Dimensions

### Basic type (Knob): IR10□0-01□-A

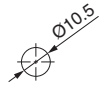
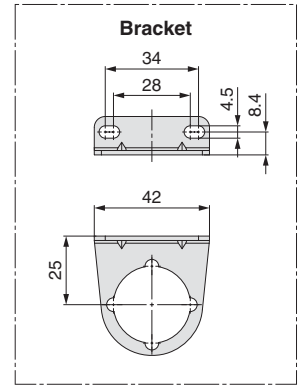
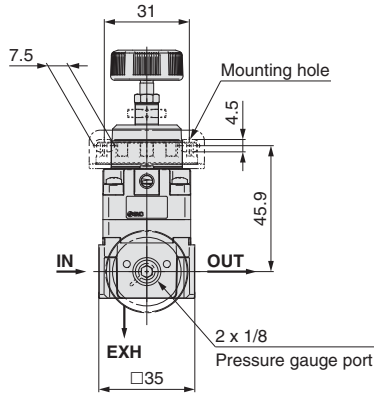
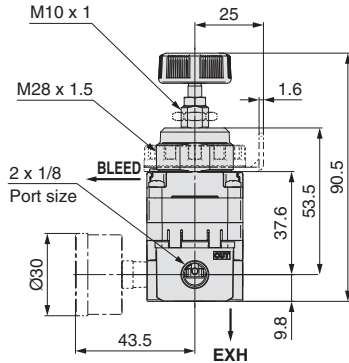

Mounting hole for hexagon panel nut

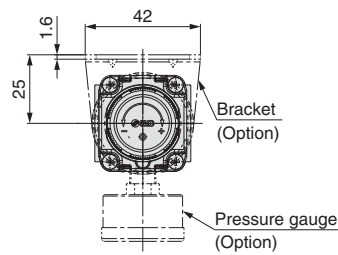
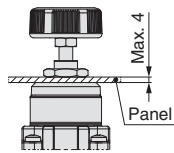

When connecting to the EXH port, contact your SMC sales representative separately.

### With digital pressure switch: IR10□0-01□E□-A

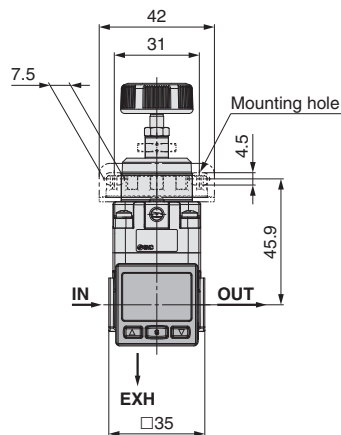
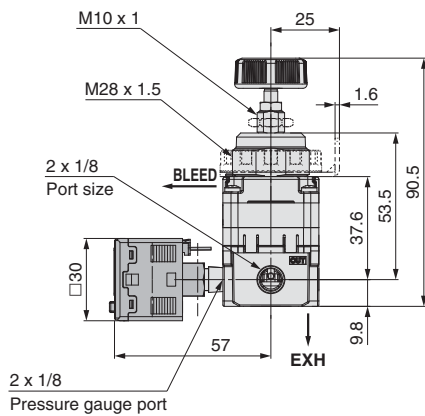

# Series IR1000-A/2000-A/3000-A

## Dimensions

Basic type (Knob): IR20□0-02□-A

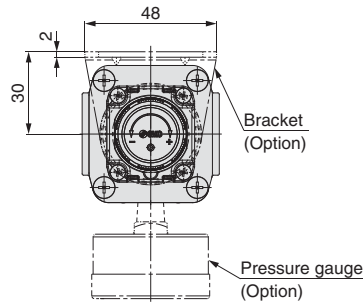
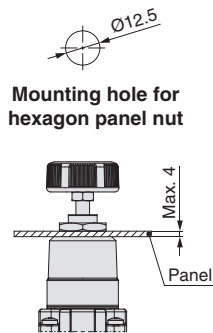
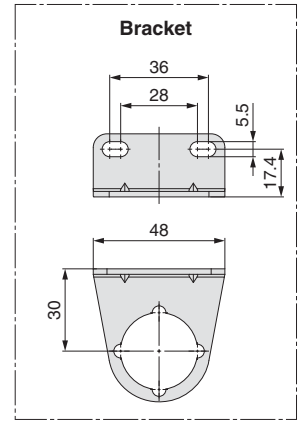
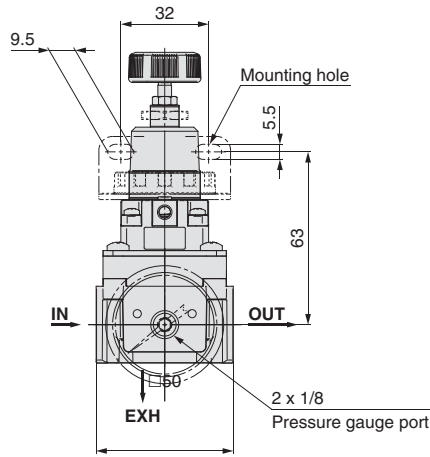
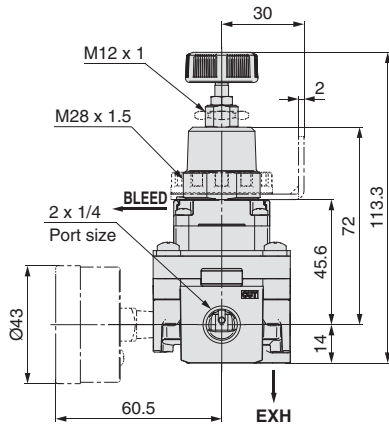

When connecting to the EXH port, contact your SMC sales representative separately.

With digital pressure switch: IR20□0-02□E□-A

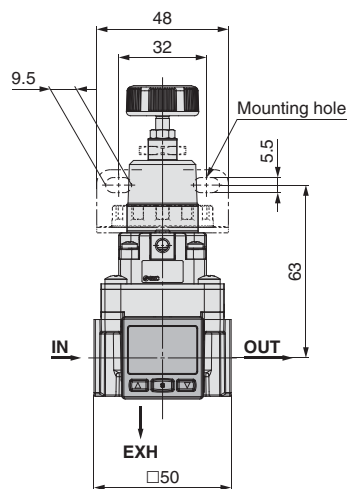
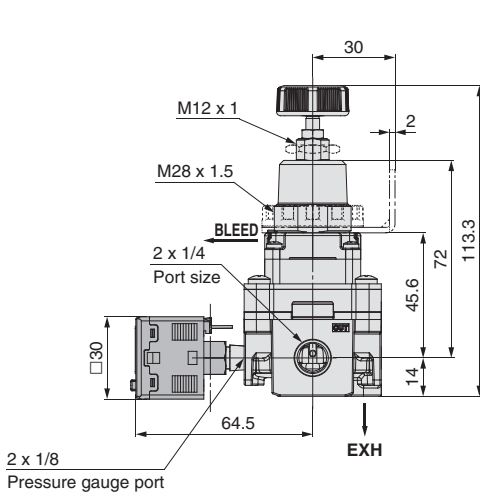

# Precision Regulator *Series IR1000-A/2000-A/3000-A*

## Dimensions

### Basic type (Knob): IR30□0-0□□□-A

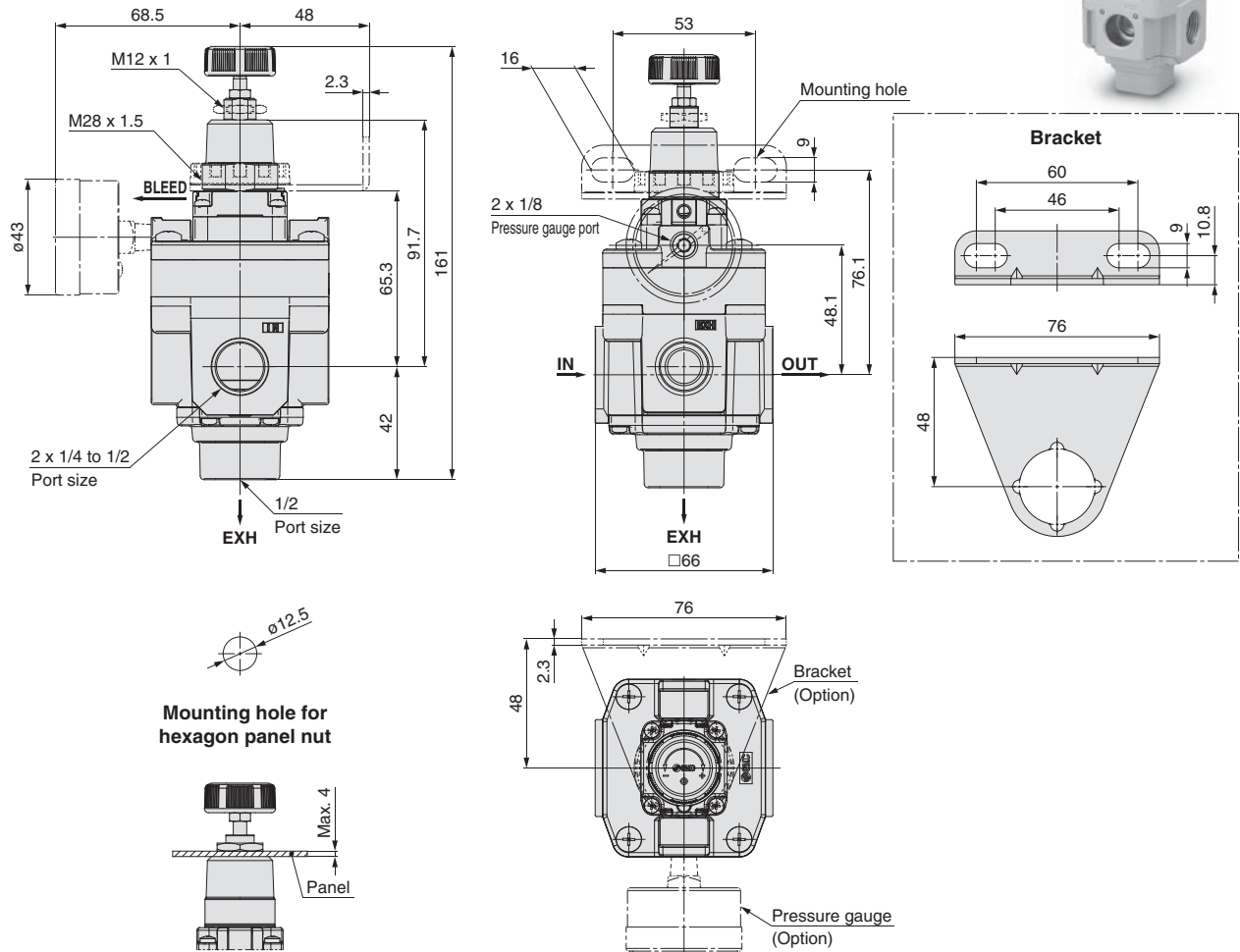

### With digital pressure switch: IR30□0-0□□□E□-A

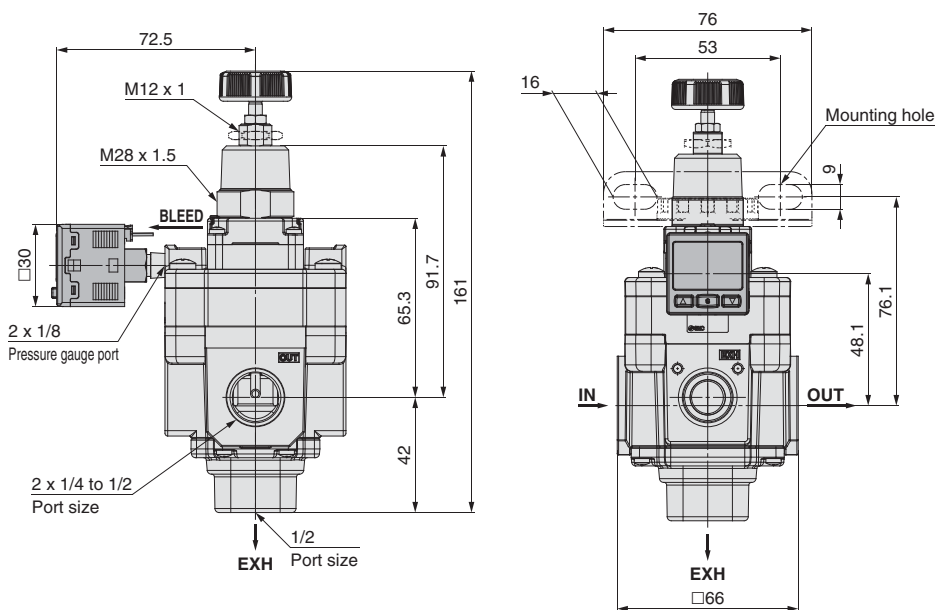

# Series IR1000-A/2000-A/3000-A

## Dimensions

### Basic type (Knob): IR30□<sub>2</sub>-0□□-A

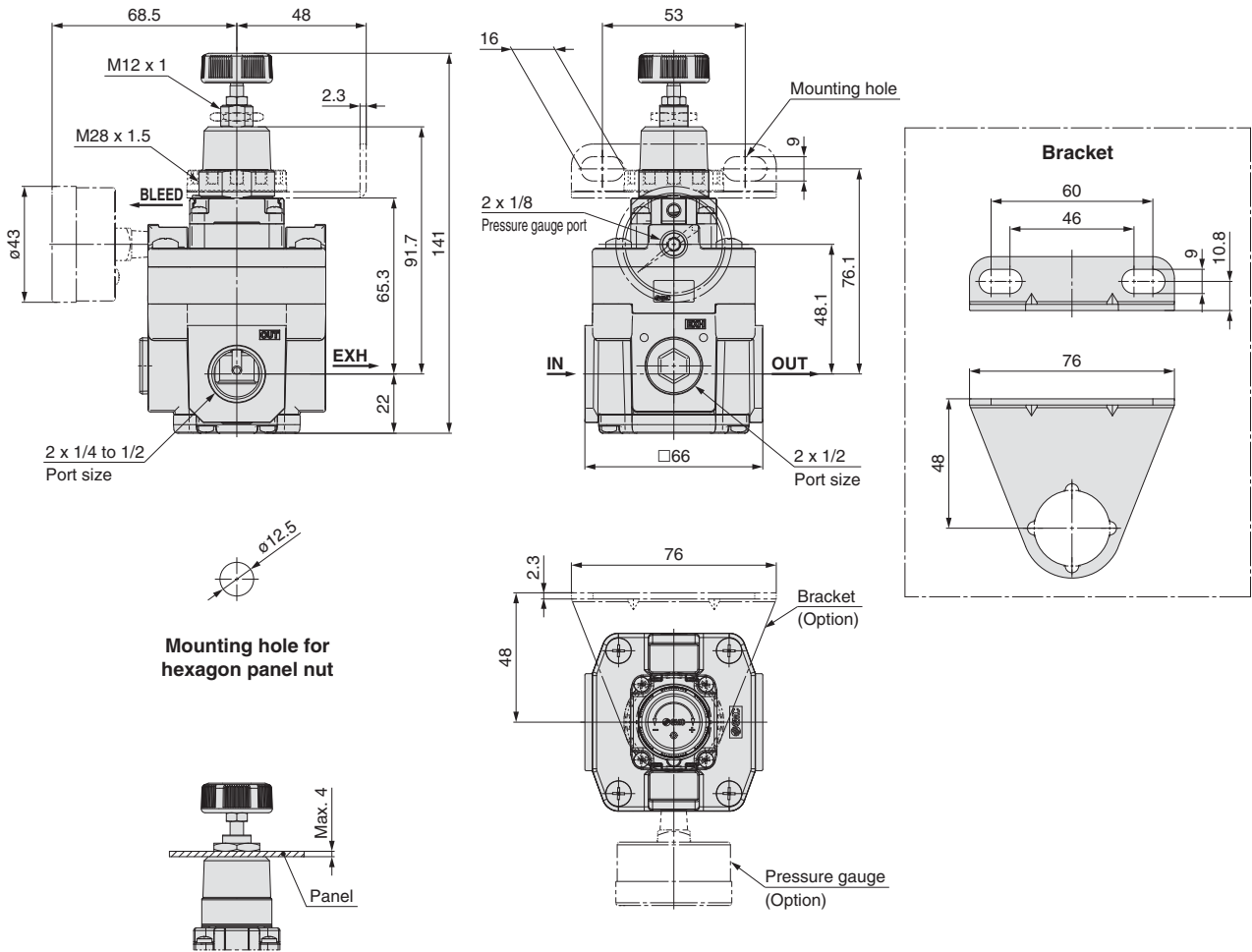

### With digital pressure switch: IR30□<sub>2</sub>-0□□E□-A

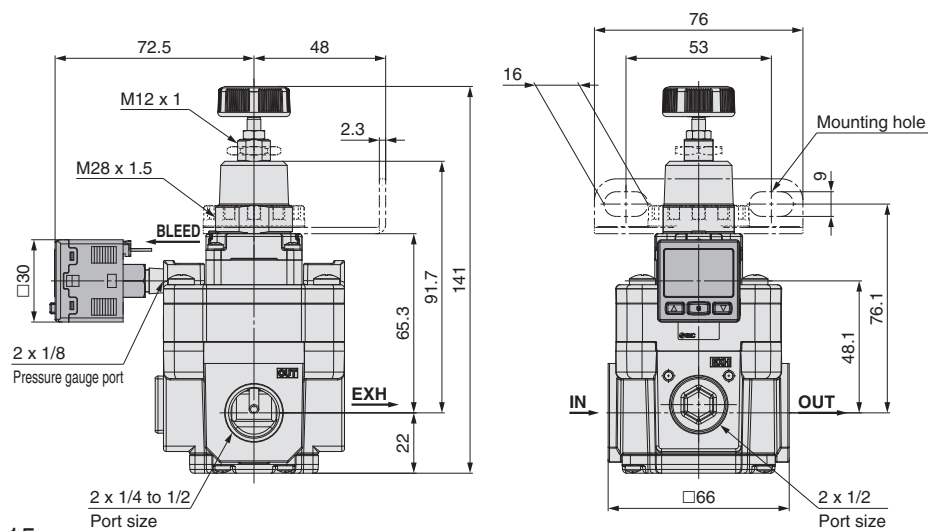





# Series IR1000-A/2000-A/3000-A Specific Product Precautions 1

Be sure to read this before handling. Refer to the back cover for Safety Instructions. For F.R.L. Units Precautions, refer to "Handling Precautions for SMC Products" and the Operation Manual on SMC website, <http://www.smc.eu>

## Piping

### Warning

1. Screw piping together with the recommended proper torque while holding the side with the female threads.

Looseness or faulty sealing will occur if tightening torque is insufficient, while thread damage will result if the torque is excessive.

Furthermore, if the side with the female threads is not held while tightening, excessive force will be applied directly to piping brackets, etc., causing damage or other problems.

#### Recommended Proper Torque [N·m]

Connection thread	1/8	1/4	3/8	1/2 (Note)
Torque	7 to 9	12 to 14	22 to 24	28 to 30

Note) Tightening force for connecting to the EXH port of IR30□<sub>2</sub>-A is 8 to 10 N·m.

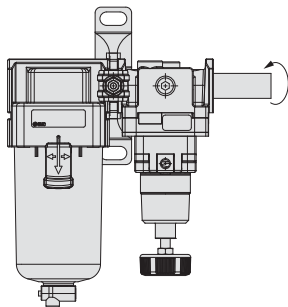

2. Do not allow twisting or bending moment to be applied other than the weight of the equipment.

Provide separate support for external piping, as damage may otherwise occur.

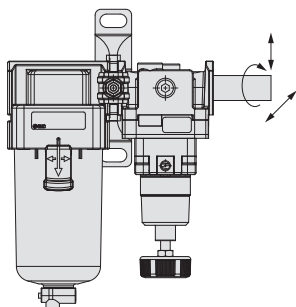

3. Piping materials without flexibility such as steel tube piping are prone to be effected by excess moment load and vibration from the piping side. Use flexible tubing in between to avoid such an effect.

### Caution

1. Preparation before piping

Before piping is connected, it should be thoroughly blown out with air (flushing) or washed to remove chips, cutting oil and other debris from inside the pipe.

## Piping

### Caution

2. Wrapping of sealant tape

When screwing piping or fittings into ports, ensure that metal chips from the pipe threads or sealing material do not enter the piping.

Also, when the sealant tape is used, leave 1.5 to 2 thread ridges exposed at the end of the threads.

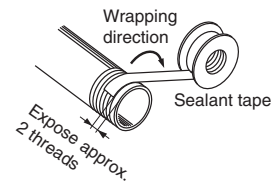

## Operating Environment

### Warning

1. Do not use in an atmosphere having corrosive gases, chemicals, sea water, water, water steam, or where there is direct contact with any of these.
2. Do not operate in locations where vibration or impact occurs.
3. In locations which receive direct sunlight, provide a protective cover, etc.
4. In locations near heat sources, block off any radiated heat.
5. In locations where there is contact with spatter from water, oil or solder, etc., implement suitable protective measures.

## Air Supply

### Warning

1. Please consult with SMC when using the product in applications other than compressed air.
2. Do not use compressed air which includes chemicals, synthetic oils containing organic solvents, salt or corrosive gases, etc., as this can cause damage or malfunction.
3. If condensate in the drain bowl is not emptied on a regular basis, the bowl will overflow and allow the condensate to enter the outlet side. This will cause a malfunction of pneumatic equipment.

When removing drain is difficult, the use of a filter with an auto drain is recommended.

### Caution

1. Condensate or dust, etc. in the supply pressure line can cause malfunctions. In addition to an air filter (SMC Series AF, etc.), please use a mist separator (SMC Series AM, AFM) depending on the conditions. Refer to catalogue on SMC website [www.smc.eu](http://www.smc.eu) for air quality.
2. When a lubricator is used at the supply side of the product, it can cause malfunctions. Do not use a lubricator at the supply side of the product.

If lubrication is required for terminal devices, connect a lubricator on the output side of the regulator.



# Series IR1000-A/2000-A/3000-A Specific Product Precautions 2

Be sure to read this before handling. Refer to the back cover for Safety Instructions. For F.R.L. Units Precautions, refer to "Handling Precautions for SMC Products" and the Operation Manual on SMC website, <http://www.smc.eu>

## Maintenance

### ⚠ Warning

1. When the product is removed for maintenance, reduce the set pressure to "0" and shut off the supply pressure completely beforehand.
2. When a pressure gauge is to be mounted, remove the plug after reducing the set pressure to "0".
3. When using the regulator between a solenoid valve and an actuator, check the pressure gauge periodically. Sudden pressure fluctuations may shorten the durability of the pressure gauge.  
A digital pressure gauge is recommended for such situation or as deemed necessary.

## Handling

### ⚠ Caution

1. When the precision regulator with pressure gauge is used, do not apply impact to the product by dropping it, etc. during transportation or installation.  
This may cause misalignment of the pressure gauge pointer.

## Operation

### ⚠ Caution

1. Do not use a precision regulator outside the range of its specifications as this can cause failure. (Refer to the specifications.)
2. When mounting is performed, make connections while confirming port indications.
3. When mounting the bracket or tightening the hexagon panel nut on the panel, tighten them to the recommended proper torque.  
Looseness or faulty sealing will occur if tightening torque is insufficient, while thread damage will result if the torque is excessive.  
**Recommended Proper Torque [N·m]**  
Set nut (for bracket)  

IR10□0-A	IR20□0-A	IR30□□-A
2.0 ±0.2		

Hexagon panel nut (for knob type only)  

IR10□0-A	IR20□0-A	IR30□□-A
3.5 ±0.5		
4. After pressure adjustment, be sure to tighten the lock nut. When tightening the nut, tighten so that the knob does not move due to friction caused by tightening.

## Operation



### ⚠ Caution

5. When pressure is applied to the inlet of a regulator, make sure that the output is connected to the circuit. Air blow occurs from the outlet and it depends on the operating conditions.
6. The set pressure may vary depending on the elapsed time and change in ambient temperature after pressure setting. If the setting value varies, adjust with the knob.
7. If the directional control valve (solenoid valve, mechanical valve, etc.) is mounted and ON-OFF is repeated for a long time, the set pressure may vary. If the setting value varies, adjust with the knob.
8. There may be pulsation or noise depending on the pressure conditions, piping conditions and ambient environment. In this case, it is possible to improve the problem by changing the pressure conditions and piping conditions.  
If the problem is not improved, contact your SMC sales representative.
9. The capacity of the output side is large, and when used for the purpose of a relief function, the exhaust sound will be loud when being relieved. Therefore, operate with a silencer (SMC Series AN, etc.) mounted on the exhaust port (EXH port).  
When using the IR1000-A and 2000-A series, contact your SMC sales representative.
10. When installing a pressure gauge to the product, do not apply pressure more than the maximum display pressure. This will cause a malfunction.



## Safety Instructions

These safety instructions are intended to prevent hazardous situations and/or equipment damage. These instructions indicate the level of potential hazard with the labels of “Caution,” “Warning” or “Danger.” They are all important notes for safety and must be followed in addition to International Standards (ISO/IEC)\*1, and other safety regulations.

-  **Caution:** Caution indicates a hazard with a low level of risk which, if not avoided, could result in minor or moderate injury.
-  **Warning:** Warning indicates a hazard with a medium level of risk which, if not avoided, could result in death or serious injury.
-  **Danger:** Danger indicates a hazard with a high level of risk which, if not avoided, will result in death or serious injury.

\*1) ISO 4414: Pneumatic fluid power – General rules relating to systems.  
 ISO 4413: Hydraulic fluid power – General rules relating to systems.  
 IEC 60204-1: Safety of machinery – Electrical equipment of machines.  
 (Part 1: General requirements)  
 ISO 10218-1: Manipulating industrial robots - Safety.  
 etc.

### Warning

#### 1. The compatibility of the product is the responsibility of the person who designs the equipment or decides its specifications.

Since the product specified here is used under various operating conditions, its compatibility with specific equipment must be decided by the person who designs the equipment or decides its specifications based on necessary analysis and test results. The expected performance and safety assurance of the equipment will be the responsibility of the person who has determined its compatibility with the product. This person should also continuously review all specifications of the product referring to its latest catalogue information, with a view to giving due consideration to any possibility of equipment failure when configuring the equipment.

#### 2. Only personnel with appropriate training should operate machinery and equipment.

The product specified here may become unsafe if handled incorrectly. The assembly, operation and maintenance of machines or equipment including our products must be performed by an operator who is appropriately trained and experienced.

#### 3. Do not service or attempt to remove product and machinery/equipment until safety is confirmed.

1. The inspection and maintenance of machinery/equipment should only be performed after measures to prevent falling or runaway of the driven objects have been confirmed.
2. When the product is to be removed, confirm that the safety measures as mentioned above are implemented and the power from any appropriate source is cut, and read and understand the specific product precautions of all relevant products carefully.
3. Before machinery/equipment is restarted, take measures to prevent unexpected operation and malfunction.

#### 4. Contact SMC beforehand and take special consideration of safety measures if the product is to be used in any of the following conditions.

1. Conditions and environments outside of the given specifications, or use outdoors or in a place exposed to direct sunlight.
2. Installation on equipment in conjunction with atomic energy, railways, air navigation, space, shipping, vehicles, military, medical treatment, combustion and recreation, or equipment in contact with food and beverages, emergency stop circuits, clutch and brake circuits in press applications, safety equipment or other applications unsuitable for the standard specifications described in the product catalogue.
3. An application which could have negative effects on people, property, or animals requiring special safety analysis.
4. Use in an interlock circuit, which requires the provision of double interlock for possible failure by using a mechanical protective function, and periodical checks to confirm proper operation.

## Limited warranty and Disclaimer/ Compliance Requirements

The product used is subject to the following “Limited warranty and Disclaimer” and “Compliance Requirements”.

Read and accept them before using the product.

### Limited warranty and Disclaimer

1. The warranty period of the product is 1 year in service or 1.5 years after the product is delivered, whichever is first.\*2)  
 Also, the product may have specified durability, running distance or replacement parts. Please consult your nearest sales branch.
2. For any failure or damage reported within the warranty period which is clearly our responsibility, a replacement product or necessary parts will be provided. This limited warranty applies only to our product independently, and not to any other damage incurred due to the failure of the product.
3. Prior to using SMC products, please read and understand the warranty terms and disclaimers noted in the specified catalogue for the particular products.

\*2) Vacuum pads are excluded from this 1 year warranty.

A vacuum pad is a consumable part, so it is warranted for a year after it is delivered.

Also, even within the warranty period, the wear of a product due to the use of the vacuum pad or failure due to the deterioration of rubber material are not covered by the limited warranty.

### Compliance Requirements

1. The use of SMC products with production equipment for the manufacture of weapons of mass destruction (WMD) or any other weapon is strictly prohibited.
2. The exports of SMC products or technology from one country to another are governed by the relevant security laws and regulations of the countries involved in the transaction. Prior to the shipment of a SMC product to another country, assure that all local rules governing that export are known and followed.

### Caution

#### 1. The product is provided for use in manufacturing industries.

The product herein described is basically provided for peaceful use in manufacturing industries.

If considering using the product in other industries, consult SMC beforehand and exchange specifications or a contract if necessary.

If anything is unclear, contact your nearest sales branch.

### Caution

#### SMC products are not intended for use as instruments for legal metrology.

Measurement instruments that SMC manufactures or sells have not been qualified by type approval tests relevant to the metrology (measurement) laws of each country. Therefore, SMC products cannot be used for business or certification ordained by the metrology (measurement) laws of each country.

 Safety Instructions Be sure to read “Handling Precautions for SMC Products” (M-E03-3) before using.

#### SMC Corporation (Europe)

Austria	☎+43 (0)2262622800	www.smc.at	office@smc.at	Lithuania	☎+370 5 2308118	www.smclt.lt	info@smclt.lt
Belgium	☎+32 (0)33551464	www.smc pneumatics.be	info@smc pneumatics.be	Netherlands	☎+31 (0)205318888	www.smc pneumatics.nl	info@smc pneumatics.nl
Bulgaria	☎+359 (0)2807670	www.smc.bg	office@smc.bg	Norway	☎+47 67129020	www.smc-norge.no	post@smc-norge.no
Croatia	☎+385 (0)13707288	www.smc.hr	office@smc.hr	Poland	☎+48 222119600	www.smc.pl	office@smc.pl
Czech Republic	☎+420 541424611	www.smc.cz	office@smc.cz	Portugal	☎+351 226166570	www.smc.si	postpt@smc.smces.es
Denmark	☎+45 70252900	www.smc dk.com	smc@smc dk.com	Romania	☎+40 213205111	www.smcromania.ro	smcromania@smcromania.ro
Estonia	☎+372 6510370	www.smc pneumatics.ee	smc@smc pneumatics.ee	Russia	☎+7 8127185445	www.smc-pneumatik.ru	info@smc-pneumatik.ru
Finland	☎+358 207513513	www.smc.fi	smc@smc.fi	Slovakia	☎+421 (0)413213212	www.smc.sk	office@smc.sk
France	☎+33 (0)164761000	www.smc-france.fr	info@smc-france.fr	Slovenia	☎+386 (0)73885412	www.smc.ch	office@smc.si
Germany	☎+49 (0)61034020	www.smc.de	info@smc.de	Spain	☎+34 902184100	www.smc.eu	post@smc.smces.es
Greece	☎+30 210 2717265	www.smc hellas.gr	sales@smc hellas.gr	Sweden	☎+46 (0)86031200	www.smc.nu	post@smc.nu
Hungary	☎+36 23511390	www.smc.hu	office@smc.hu	Switzerland	☎+41 (0)523963131	www.smc.ch	info@smc.ch
Ireland	☎+353 (0)14039000	www.smc pneumatics.ie	sales@smc pneumatics.ie	Turkey	☎+90 212 489 0 440	www.smc pneumatik.com.tr	info@smc pneumatik.com.tr
Italy	☎+39 0292711	www.smcitalia.it	mailbox@smcitalia.it	UK	☎+44 (0)845 121 5122	www.smc pneumatics.co.uk	sales@smc pneumatics.co.uk
Latvia	☎+371 67817700	www.smc lv.lv	info@smc lv.lv				

SMC CORPORATION Akihara UDX 15F, 4-14-1, Sotokanda, Chiyoda-ku, Tokyo 101-0021, JAPAN Phone: 03-5207-8249 FAX: 03-5298-5362

1st printing TT printing TU 00 Printed in Spain

Specifications are subject to change without prior notice and any obligation on the part of the manufacturer.