

Компактный поворотный привод

CRQ2

Типоразмер: 10, 15, 20, 30, 40

Поворотный привод двустороннего действия

- Компактная конструкция (привод шестерня-рейка)
- Длительный срок службы
- Регулируемое демпфирование

Технические характеристики

Типоразмер		10	15	20	30	40
Среда		Очищенный сжатый воздух с содержанием масла или без него				
Температура окружающей среды (°C)		0~60				
Монтажное положение		Произвольное				
Угол поворота		90°, 180°, 360° (±10°)				
Исполнение вала		С лыской		Со шпонкой		
Диапазон рабочих давлений (МПа)		0.15~0.7		0.1~1		
Внутренний объем (см ³)	90°	1.2	2.9	7.1	12.1	20.6
	180°	2.2	5.5	13.5	23	39.1
	360°	4.3	10.7	26.3	44.7	76.1
Присоединительная резьба		M5	M5	G1/8	G1/8	G1/8
Вес (г)	90°	120	220	600	700	1400
	180°	150	270	700	1100	1600
	360°	200	380	1000	1510	2280
Макс. допустимая кинетическая энергия (мДж)	Без демпфера	–	–	25	48	81
	С упругим демпфером	0.25	0.39	–	–	–
	С пневмодемпфером	–	–	120	250	400
Допустимое время поворота (с/90°)		0.2~0.7		0.2~1		

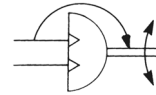
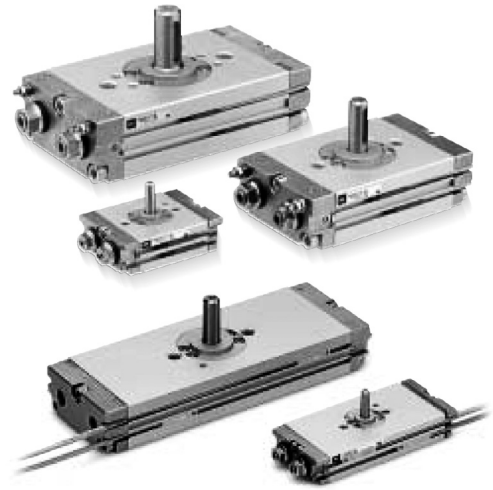

Расчет энергии вращения

$$E = \frac{1}{2} \times J \times \omega^2, \quad \omega = \frac{2\theta}{t}$$

E: кинетическая энергия (Нм)
 J: момент инерции (кгм²)
 ω: угловая скорость (с⁻¹)
 θ: угол поворота (рад), 180° = 3.14 рад
 t: время поворота (с)

Критерии выбора

Эффективный крутящий момент (Нм)

Типоразмер	Рабочее давление (МПа)										
	0.10	0.15	0.20	0.30	0.40	0.50	0.60	0.70	0.80	0.90	1.00
10	–	0.09	0.12	0.18	0.24	0.30	0.36	0.42	–	–	–
15	–	0.22	0.30	0.45	0.60	0.75	0.90	1.04	–	–	–
20	0.37	0.55	0.73	1.10	1.47	1.84	2.20	2.57	2.93	3.29	3.66
30	0.62	0.94	1.25	1.87	2.49	3.11	3.74	4.37	4.99	5.60	6.24
40	1.06	1.59	2.11	3.18	4.24	5.30	6.36	7.43	8.48	9.54	10.6

Изменение крутящего момента

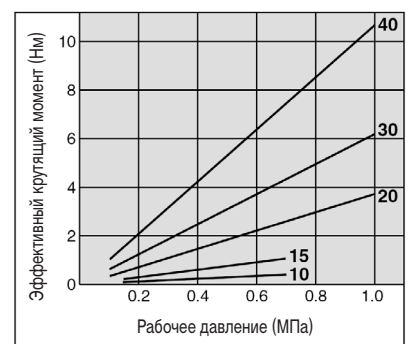

Максимально допустимая осевая и радиальная нагрузка на вал (Н)

Типоразмер	Направление усилия		
	Fsa	Fsb	Fr
10	15.7	7.8	14.7
15	19.6	9.8	19.6
20	49	29.4	49
30	98	49	78
40	108	59	98

Вышеприведенная таблица относится только к статической нагрузке. При динамической нагрузке грузы не должны устанавливаться непосредственно на поворотном валу.

При этом могут использоваться следующие конструктивные варианты.

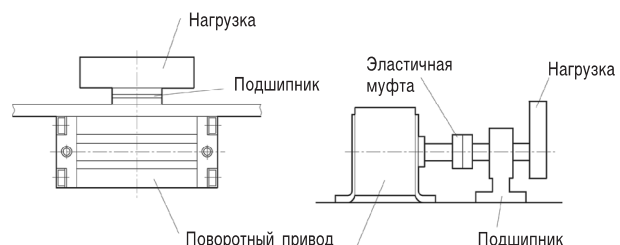

Критерии выбора

Потребление сжатого воздуха (норм.л/мин)

Типоразмер	Угол поворота	Объем (см³)	Рабочее давление, МПа										
			0.1	0.15	0.2	0.3	0.4	0.5	0.6	0.7	0.8	0.9	1.0
10	90°	1.2	–	0.006	0.007	0.009	0.012	0.014	0.016	0.018	–	–	–
	180°	2.2	–	0.011	0.013	0.018	0.022	0.026	0.031	0.035	–	–	–
	360°	4.3	–	0.021	0.026	0.034	0.043	0.051	0.060	0.068	–	–	–
15	90°	2.9	–	0.015	0.017	0.023	0.029	0.035	0.041	0.046	–	–	–
	180°	5.5	–	0.028	0.033	0.044	0.055	0.066	0.077	0.088	–	–	–
	360°	10.7	–	0.023	0.064	0.086	0.107	0.129	0.193	0.172	–	–	–
20	90°	7.1	0.028	0.036	0.043	0.057	0.071	0.085	0.099	0.114	0.128	0.142	0.156
	180°	13.5	0.054	0.068	0.081	0.108	0.135	0.162	0.189	0.216	0.243	0.270	0.297
	360°	26.3	0.105	0.131	0.158	0.210	0.263	0.316	0.368	0.421	0.473	0.526	0.578
30	90°	12.1	0.048	0.060	0.073	0.097	0.121	0.145	0.169	0.193	0.218	0.242	0.266
	180°	23.0	0.092	0.115	0.138	0.184	0.230	0.276	0.322	0.368	0.413	0.459	0.505
	360°	44.7	0.179	0.224	0.268	0.358	0.447	0.537	0.626	0.716	0.805	0.895	0.984
40	90°	20.6	0.082	0.103	0.123	0.164	0.206	0.247	0.288	0.329	0.370	0.411	0.452
	180°	39.1	0.156	0.195	0.234	0.313	0.391	0.469	0.547	0.625	0.703	0.781	0.859
	360°	76.1	0.304	0.380	0.456	0.609	0.761	0.913	1.07	1.22	1.37	1.52	1.67

Номер для заказа

С односторонним валом

Без регулируемого демпфера

Типоразмер	Угол поворота 80~100°	Угол поворота 170~190°	Угол поворота 350~370°
10	CDRQ2BS10-90	CDRQ2BS10-180	CDRQ2BS10-360
15	CDRQ2BS15-90	CDRQ2BS15-180	CDRQ2BS15-360
20	CDRQ2BS20-90	CDRQ2BS20-180	CDRQ2BS20-360
30	CDRQ2BS30-90	CDRQ2BS30-180	CDRQ2BS30-360
40	CDRQ2BS40-90	CDRQ2BS40-180	CDRQ2BS40-360

С регулируемым демпфером

Типоразмер	Угол поворота 80~100°	Угол поворота 170~190°	Угол поворота 350~370°
20	CDRQ2BS20-90C	CDRQ2BS20-180C	CDRQ2BS20-360C
30	CDRQ2BS30-90C	CDRQ2BS30-180C	CDRQ2BS30-360C
40	CDRQ2BS40-90C	CDRQ2BS40-180C	CDRQ2BS40-360C

С двусторонним валом

Без регулируемого демпфера

Типоразмер	Угол поворота 80~100°	Угол поворота 170~190°	Угол поворота 350~370°
10	CDRQ2BW10-90	CDRQ2BW10-180	CDRQ2BW10-360
15	CDRQ2BW15-90	CDRQ2BW15-180	CDRQ2BW15-360
20	CDRQ2BW20-90	CDRQ2BW20-180	CDRQ2BW20-360
30	CDRQ2BW30-90	CDRQ2BW30-180	CDRQ2BW30-360
40	CDRQ2BW40-90	CDRQ2BW40-180	CDRQ2BW40-360

С регулируемым демпфером

Типоразмер	Угол поворота 80~100°	Угол поворота 170~190°	Угол поворота 350~370°
20	CDRQ2BW20-90C	CDRQ2BW20-180C	CDRQ2BW20-360C
30	CDRQ2BW30-90C	CDRQ2BW30-180C	CDRQ2BW30-360C
40	CDRQ2BW40-90C	CDRQ2BW40-180C	CDRQ2BW40-360C

Датчики положения заказываются отдельно.

Технические характеристики и данные по заказу см. на стр. 2-126, 2-219

Компактный поворотный привод CRQ2

Конструкция

Основное исполнение Типоразмер 10/15

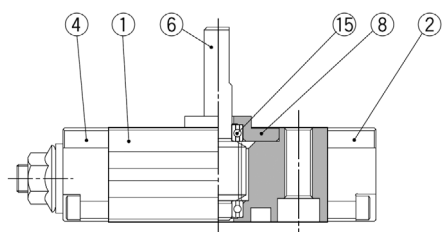
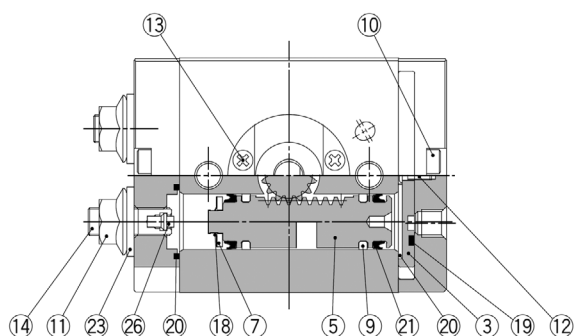

Основное исполнение Типоразмер 20/30/40

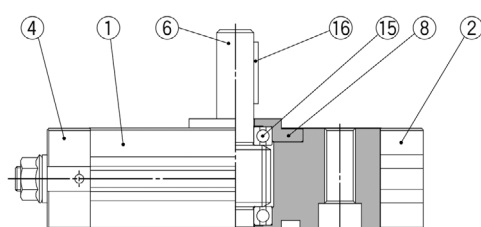
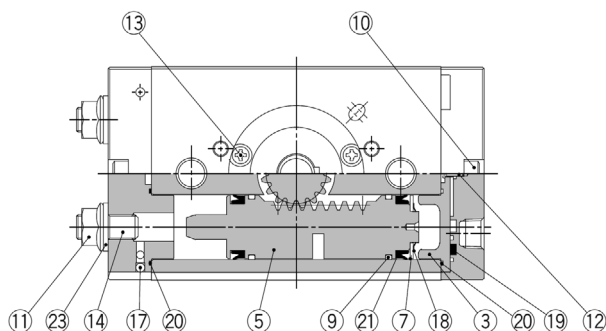

Спецификация

Поз.	Наименование	Материал	
1	Корпус	Алюминиевый сплав	
2	Крышка	Алюминиевый сплав	
3	Упорная пластина	Алюминиевый сплав	
4	Задняя крышка	Алюминиевый сплав	
5	Поршень	Сталь	
6	Вал	10, 15	Сталь
		20, 30, 40	Хромомолибденовая сталь
7	Опорная шайба	Алюминиевый сплав	
8	Верхняя крышка	Алюминиевый сплав	
9	Центрирующее кольцо	Пластик	
10, 14	Винт с шестигранником	Сталь	
11	Гайка	—	
12, 13	Винт с крестообразным шлицем	—	
15	Шарикоподшипник	Сталь	
16	Прямоугольный ключ	Сталь	
17	Шариковый ключ	Сталь	
18	Стопорное кольцо	—	
19	Прокладка	NBR	
20	Уплотнение	NBR	
21	Поршневое уплотнение	NBR	
22	Демпфер	—	
23	Уплотнительная шайба	NBR	
24	Магнит	—	
25	Клапан пневмодемпфера	—	
26	Демпферное уплотнение	—	

Ремкомплект

Включает поз. 19, 20, 21, 23

Типоразмер	Номер для заказа
10	P473010-1
15	P473020-1
20	P473030-1
30	P473040-1
40	P473050-1

Размеры

Типоразмер 10/15

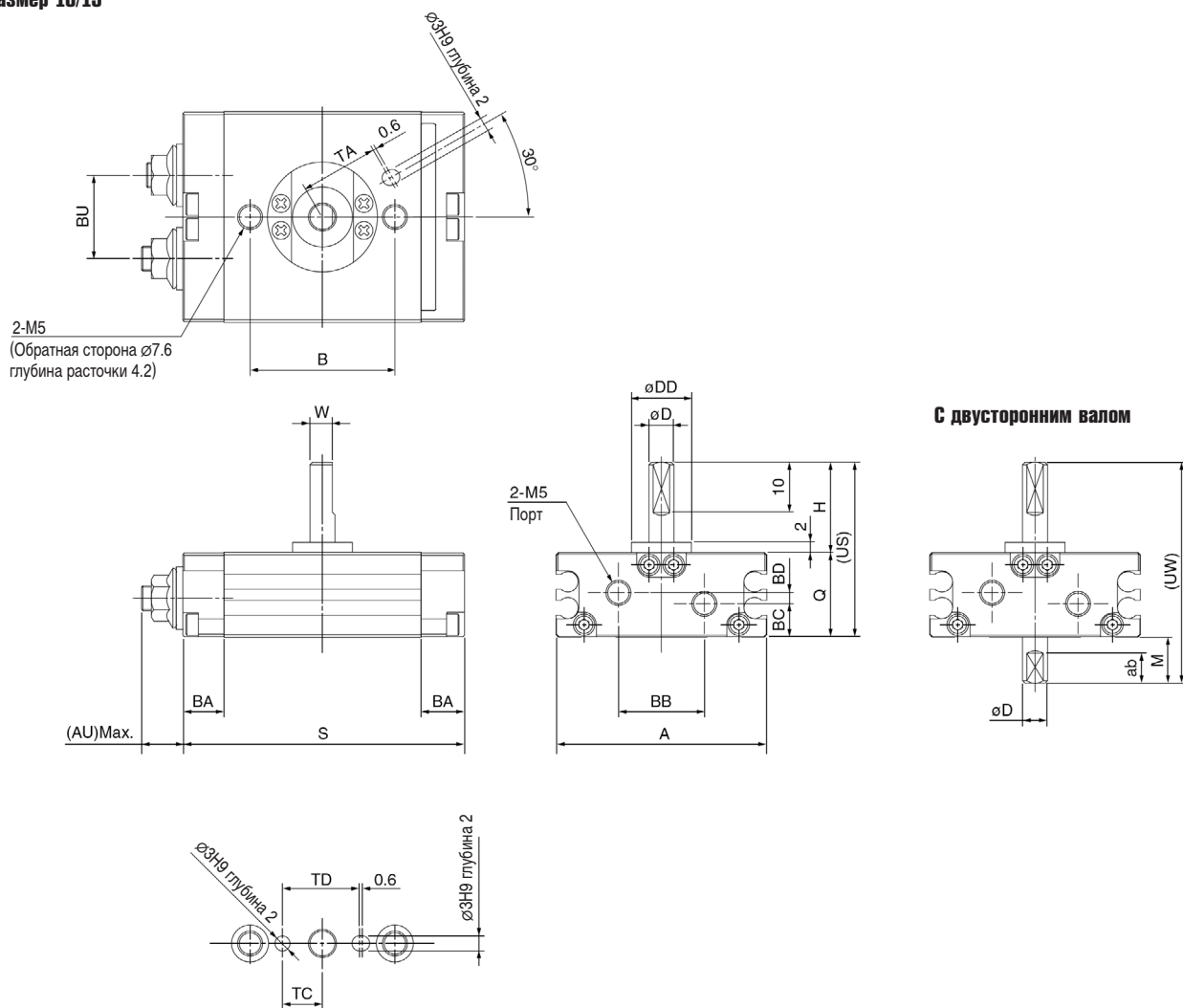

С двусторонним валом

Компания SMC сохраняет за собой право на внесение технических и размерных изменений

Типоразмер	Угол поворота	A	AU	B	BA	BB	BC	BD	BU	D	DD	H
10	90, 180, 360°	42	8.5	29	8.5	17	6.7	2.2	16.7	5	12	18
15	90, 180, 360°	53	9.5	31	9	26.4	10.6	-	23.1	6	14	20

Типоразмер	Угол поворота	W	Q	S	US	UW	ab	M	TA	TC	TD
10	90°	4.5	17	56	35	44	6	9	15.5	8	15.4
	180°			69							
	360°			97							
15	90°	5.5	20	65	40	50	7	10	16	9	17.6
	180°			82							
	360°			116							

Компактный поворотный привод CRQ2

Размеры

Типоразмер 20/30/40

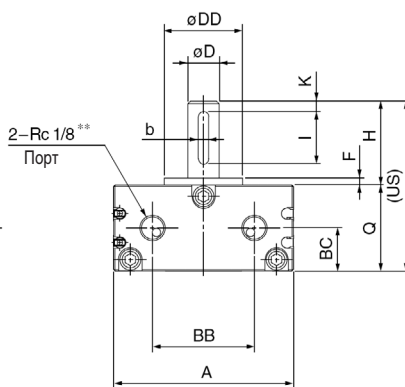
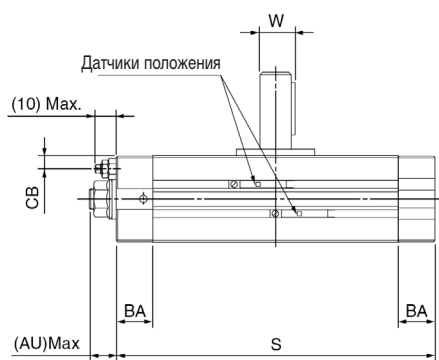
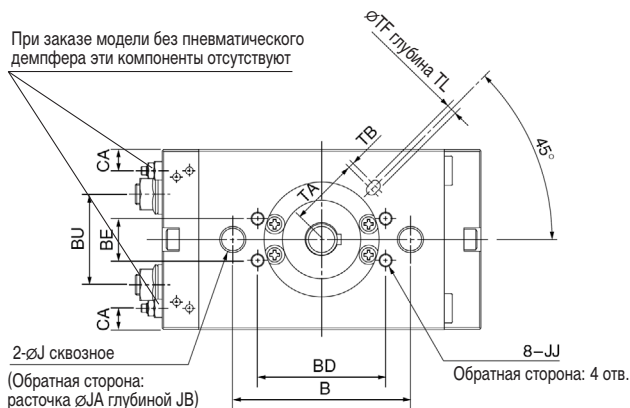

С двусторонним валом

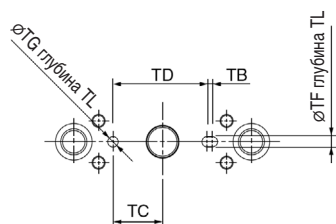
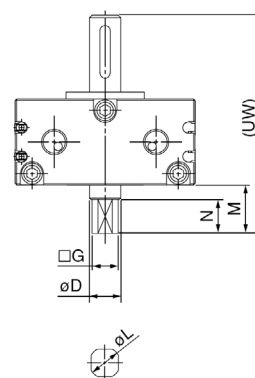

Типоразмер	Угол поворота	A	AU	B	BA	BB	BC	BD	BE	BU	CA	CB	D	DD	F	H	J	JA	JB
20	90, 180, 360°	63	11	50	14	34	14.5	-	-	30.4	7	4.7	10	25	2.5	30	M8	11	6.5
30		69	11	68	14	39	16.5	49	16	34.7	8.1	4.9	12	30	3	32	M10	14	8.5
40		78	13	76	16	47	18.5	55	16	40.4	8.3	5.2	15	32	3	36	M10	14	8.6

Типоразмер	Угол поворота	JJ	K	Q	S	W	Размеры ключа		US	TA	TB	TC	TD	TF	TG	TL	UW	G	M	N	L
							B	I													
20	90°	-	3	29	104	11.5	4	20	59	24.5	1	13.5	27	4	4	2.5	74	8	15	11	9.6
	180°		130																		
	360°		180																		
30	90°	M5	4	33	122	13.5	4	20	65	27	2	19	36	4	4	2.5	83	10	18	13	11.4
	180°	глуб.			153																
	360°	6			216																
40	90°	M6	5	37	139	17	5	25	73	32.5	2	20	39.5	5	5	3.5	93	11	20	15	14
	180°	глуб.			177																
	360°	7			253																

Время поворота

Без демпфирования

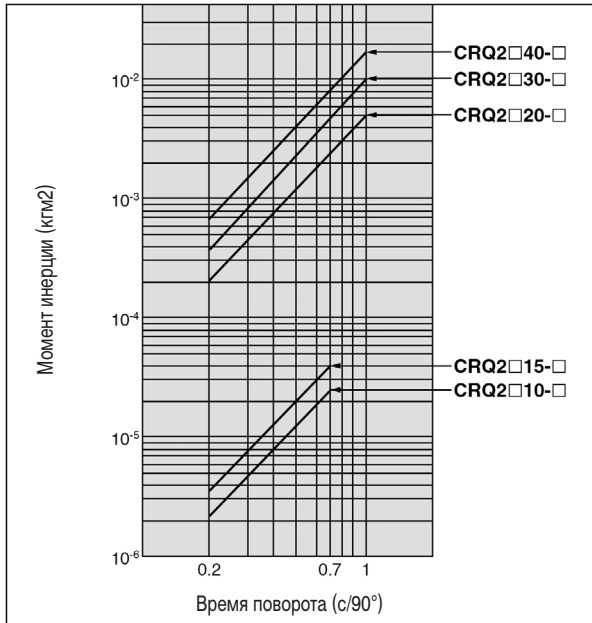

С демпфированием

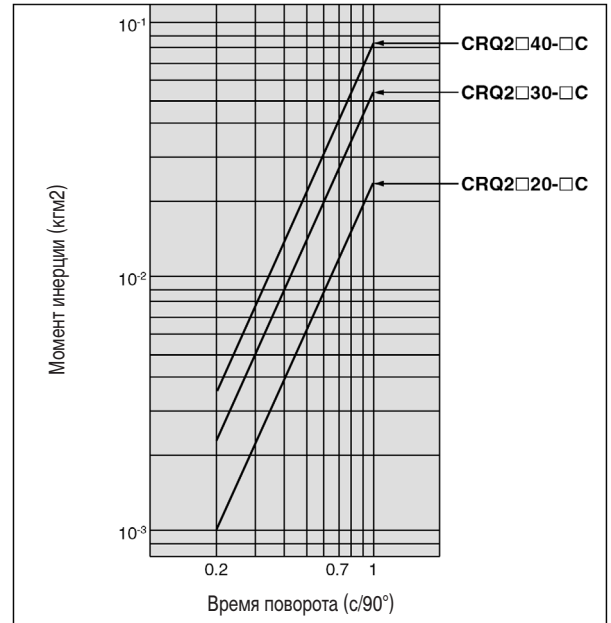

Компактный поворотный привод CRQ2

Датчики положения

На привод CRQ2 устанавливаются универсальные датчики положения: электронные D-M9N(V)L, D-M9P(V)L, D-M9B(V)L и герконовые D-A90(V)L, D-A93(V)L (см. стр. 2-219)

Способ установки – в профильные пазы привода.

Монтажное положение датчиков положения в зависимости от угла поворота D-A9(V), D-M9(V)

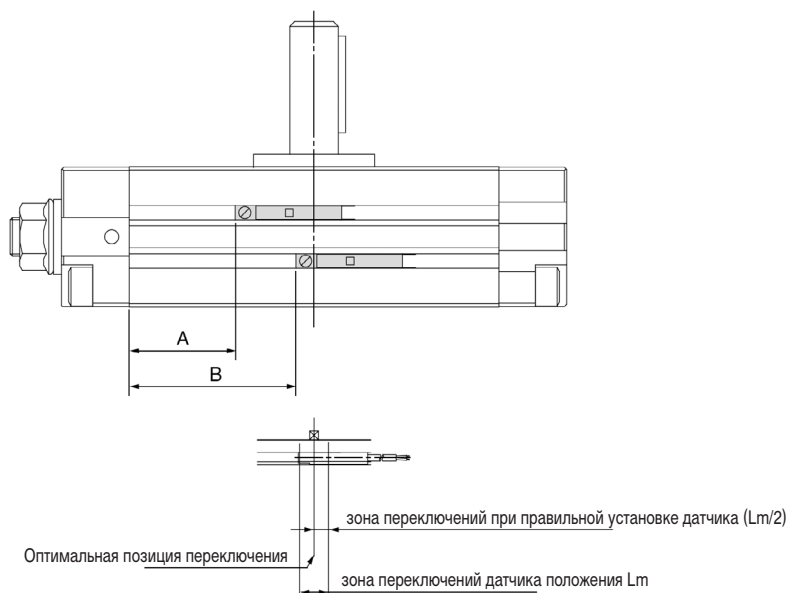

Типоразмер	Угол поворота	Герконовые датчики			Электронные датчики		
		A	B	гистерезис	A	B	гистерезис
10	90°	6.5	13	12°	10.5	17	3°
	180°	9.5	22.5		13.5	26.5	
15	90°	9.5	18	9°	13.5	22	3°
	180°	13.5	30.5		17.5	34.5	
20	90°	22	34.5	9°	26	38.5	4°
	180°	28	53.5		32	57.5	
30	90°	29	45	7°	33	49	3°
	180°	37	68		41	72	
40	90°	34	53	5°	38	57	4°
	180°	43.5	81.5		47.5	85.5	

Low-Speed Rotary Actuator

Possible to transfer a workpiece at low-speed.

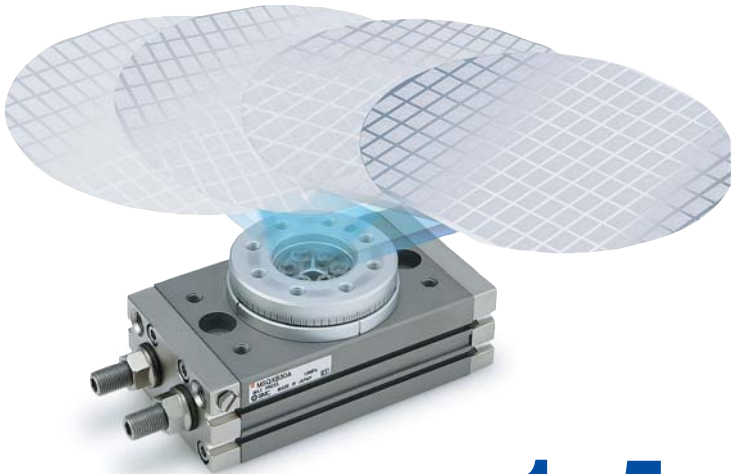

- Realized a stable motion at 5s/90°.

Smooth motion without stick-slip phenomenon

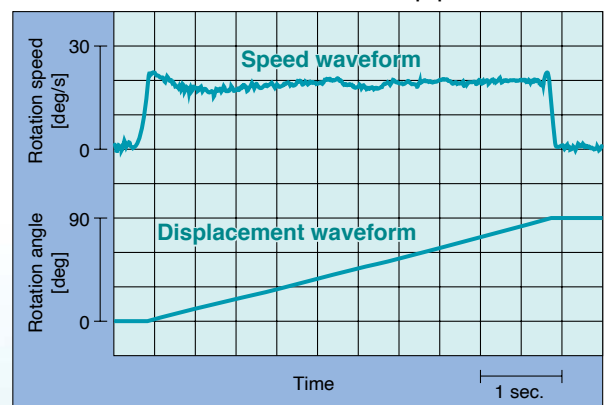

- Rotation time adjustment range: **1 to 5** (s/90°)

Model	Size	Rotation time adjustment range (s/90°)					
		1	2	3	4	5	
Low-speed	CRQ2X	10, 15, 20, 30, 40	1 to 5 (0.7 to 5 for CRQ2X□10,15)				
	MSQX	10, 20, 30, 50					
Standard	CRQ2	10, 15, 20, 30, 40	0.2 to 1 (0.2 to 0.7 for CRQ2□10,15)				
	MSQ	10, 20, 30, 50					

Measurement conditions / Fluid: Air

Mounting orientation: Horizontal without load

Operating pressure: 0.5 MPa

Pneumatic circuit: Meter-out circuit

Ambient temperature: Room temperature

- Dimensions compatible with the CRQ2, MSQ series

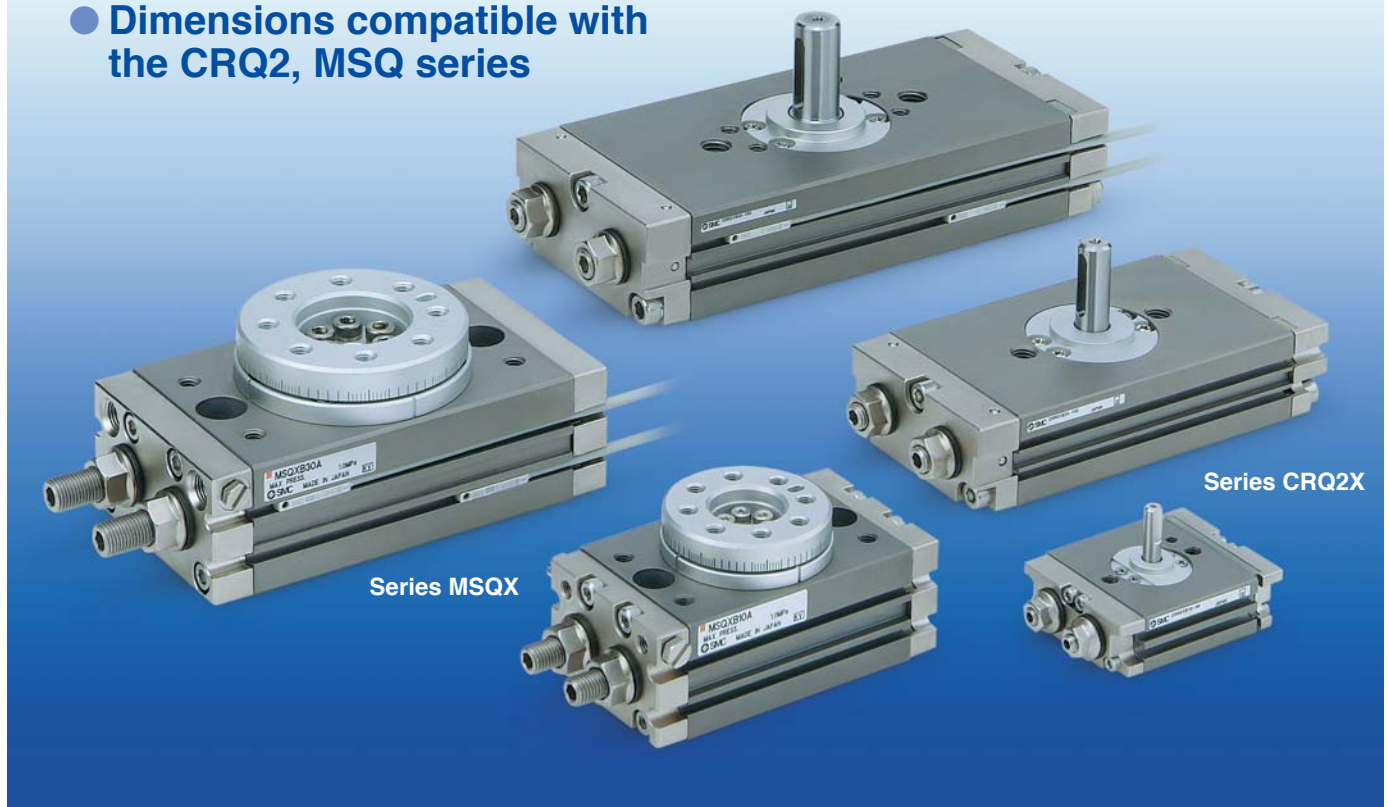

Series **CRQ2X/MSQX**

Series CRQ2X/MSQX Model Selection

* The selection procedure of the rotary for low-speed is the same as for an ordinary rotary. If the rotation time exceeds 2s per 90°, however, the necessary torque and the kinetic energy are calculated with rotation time of 2s per 90°.

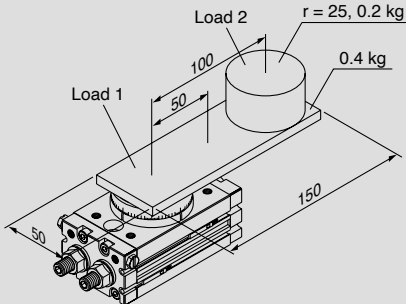
Selection Procedure	Remarks	Selection Example
<p>0 Operating conditions</p> <p>Operating conditions are as follows:</p> <ul style="list-style-type: none"> Provisionally selected model Operating pressure: MPa Mounting position Load type <ul style="list-style-type: none"> Static load: N·m Resistance load: N·m Inertial load: N·m Load dimension: m Load mass: kg Rotation time: s Rotation angle: rad 	<ul style="list-style-type: none"> See P.3 for load type. The unit of the rotation angle is Radians. 180° = π rad 90° = π/2 rad 	 <p>Provisionally selected model: MSQXB10A Operating pressure: 0.3 MPa Mounting position: Vertical, Type of load: Inertial load Rotation time: 6s Rotation angle: π rad (180°)</p>
<p>1 Calculation of moment of inertia</p> <p>Calculate the moment of inertia of the load. ⇒ P.2</p>	<ul style="list-style-type: none"> If the moment of inertia of the load is made up of multiple components, calculate the moment of inertia of each component and add them together. 	<p>Load 1 moment of inertia: I₁ $I_1 = 0.4 \times \frac{0.15^2 + 0.05^2}{12} + 0.4 \times 0.05^2 = 0.001833$ Load 2 moment of inertia: I₂ $I_2 = 0.2 \times \frac{0.025^2}{2} + 0.2 \times 0.1^2 = 0.002063$ Total moment of inertia: I $I = I_1 + I_2 = 0.003896 \text{ [kg} \cdot \text{m}^2\text{]}$ </p>
<p>2 Calculation of necessary torque</p> <p>Calculate necessary torque corresponding to the load type, and ensure it is within effective torque range.</p> <ul style="list-style-type: none"> Static load (T_s) Necessary torque T = T_s Resistance load (T_f) Necessary torque T = T_f x (3 to 5) Inertial load (T_a) Necessary torque T = T_a x 10 ⇒ P.3 	<ul style="list-style-type: none"> When calculating the inertial load, if the rotation time exceeds 2s per 90°, inertial load is calculated with rotation time of 2s per 90°. Even for resistance load, when the load is rotated, necessary torque calculated from inertial load shall be added. <p>Necessary torque T = T_f x (3 to 5) + T_a x 10</p>	<p>Inertial load: T_a $T_a = I \cdot \dot{\omega}$ $\dot{\omega} = \frac{2\theta}{t^2} \text{ [rad/s}^2\text{]}$ Necessary torque: T $T = T_a \times 10$ $= 0.003896 \times \frac{2 \times \pi}{4^2} \times 10 = 0.015 \text{ [N} \cdot \text{m]}$ (t is calculated with 2s per 90°.) 0.109 N·m < Effective torque OK </p>
<p>3 Checking rotation time</p> <p>Confirm that it is within the adjustable range of rotation time. ⇒ P.4</p>	<ul style="list-style-type: none"> Converted to the time per 90° for comparison. (For comparison, 6s/180° is converted to 3s/90°.) 	<p>1.0 ≤ t ≤ 5 t = 3s/90° OK</p>
<p>4 Calculation of kinetic energy</p> <p>Confirm that the load's kinetic energy is within the allowable value.</p> <p>Can be confirmed by the graph of the moment of inertia and the rotation time. ⇒ P.4</p>	<ul style="list-style-type: none"> If the rotation time exceeds 2s per 90°, kinetic energy is calculated with rotation time of 2s per 90°. If the allowable value is exceeded, an external cushioning mechanism such as an absorber needs to be installed. 	<p>$E = \frac{1}{2} \cdot I \cdot \omega^2$ $\omega = \frac{2 \cdot \theta}{t}$ Kinetic energy $\frac{1}{2} \times 0.003896 \times \left(\frac{2 \times \pi}{4}\right)^2 = 0.0048 \text{ [J]}$ (t is calculated with 2s per 90°.) 0.0048 [J] < Allowable energy OK </p>
<p>5 Checking allowable load</p> <p>Check if the load applied to the product is within the allowable range. ⇒ P.5</p>	<ul style="list-style-type: none"> If the allowable value is exceeded, an external bearing needs to be installed. 	<p>$M = 0.4 \times 9.8 \times 0.05 + 0.2 \times 9.8 \times 0.1$ $= 0.392 \text{ [N} \cdot \text{m]}$ 0.392 [N·m] < Allowable moment load OK </p>
<p>6 Calculation of air consumption and necessary air quantity</p> <p>Calculate air consumption and necessary air quantity as required. ⇒ P.6</p>		

Equation Table of Moment of Inertia (Calculation of moment of inertia I) I: Moment of inertia (kg·m²) m: Load mass (kg)

1. Thin shaft

Position of rotational axis:
Perpendicular to the shaft through the center of gravity

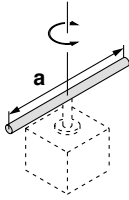

$$I = m \cdot \frac{a^2}{12}$$

2. Thin rectangular plate

Position of rotational axis:
Parallel to side b through the center of gravity

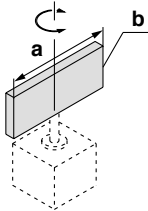

$$I = m \cdot \frac{a^2}{12}$$

3. Thin rectangular plate (Including rectangular parallelepiped)

Position of rotational axis:
Perpendicular to the plate through the center of gravity

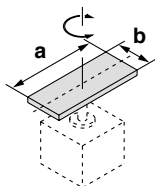

$$I = m \cdot \frac{a^2 + b^2}{12}$$

4. Round plate (Including column)

Position of rotational axis:
Passing through the center axis

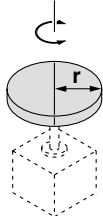

$$I = m \cdot \frac{r^2}{2}$$

5. Solid sphere

Position of rotational axis:
Passing through the diameter

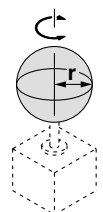

$$I = m \cdot \frac{2r^2}{5}$$

6. Thin round plate

Position of rotational axis:
Passing through the diameter

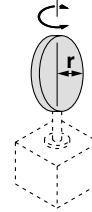

$$I = m \cdot \frac{r^2}{4}$$

7. Cylindrical

Position of rotational axis:
Passing through the diameter and the center of gravity

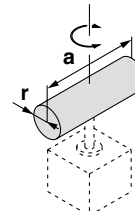

$$I = m \cdot \frac{3r^2 + a^2}{12}$$

8. When rotational axis and the center of the load are not concentric.

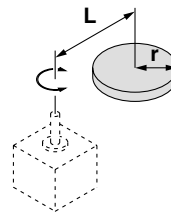

$$I = K + m \cdot L^2$$

K: The moment of inertia around the center of gravity of the load

In case of 4. Round plate $K = m \cdot \frac{r^2}{2}$

9. Gear transmission

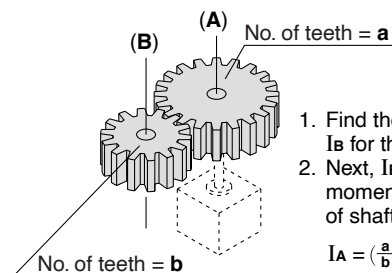

1. Find the moment of inertia I_B for the rotation of shaft (B).
2. Next, I_B is entered to find I_A the moment of inertia for the rotation of shaft (A) as

$$I_A = \left(\frac{a}{b}\right)^2 \cdot I_B$$

Model Selection

Load Type

Calculation method of necessary torque depends on the load type. Refer the below table.

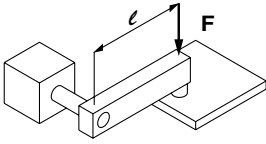
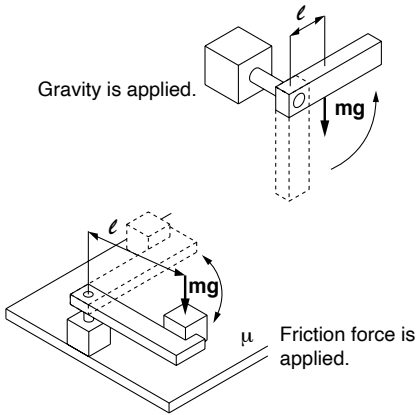
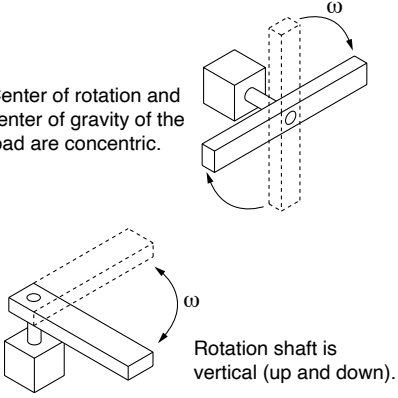
Load type		
Static load: T_s	Resistance load: T_f	Inertial load: T_a
<p>Only pressing force is necessary. (e.g. for clamping)</p> 	<p>Weight or friction force is applied to rotating direction.</p> 	<p>Rotate the load with inertia.</p> 
<p>$T_s = F \cdot l$</p> <p>T_s: Static load (N·m) F: Clamping force (N) l: Distance from the rotation center to the clamping position (m)</p>	<p>Gravity is applied in rotating direction.</p> <p>$T_f = m \cdot g \cdot l$</p> <p>Friction force is applied in rotating direction.</p> <p>$T_f = \mu \cdot m \cdot g \cdot l$</p> <p>$T_f$: Resistance load (N·m) m: Load mass (kg) g: Gravitational acceleration 9.8 (m/s²) l: Distance from the rotation center to the point of application of the weight or friction force (m) μ: Friction coefficient</p>	<p>$T_a = I \cdot \omega = I \cdot \frac{2\theta}{t^2}$</p> <p>$T_a$: Inertial load (N·m) I: Moment of inertia (kg·m²) ω: Angular acceleration (rad/s²) θ: Rotation angle (rad) t: Rotation time (s)</p> <p>For low speed rotary, if the rotation time exceeds 2s per 90°, inertial load is calculated with rotation time of 2s per 90°.</p>
Necessary torque: $T = T_s$	Necessary torque: $T = T_f \times (3 \text{ to } 5)$ ^{Note)}	Necessary torque: $T = T_a \times 10$ ^{Note)}
<p>• Resistance load: Gravity or friction force is applied to rotating direction. Ex. 1) Rotation shaft is horizontal (lateral), and the rotation center and the center of gravity of the load are not concentric. Ex. 2) Load moves by sliding on the floor</p> <p>* The total of resistance load and inertial load is the necessary torque. $T = T_f \times (3 \text{ to } 5) + T_a \times 10$</p> <p>• Not resistance load: Neither weight or friction force is applied in rotating direction. Ex. 1) Rotation shaft is vertical (up and down). Ex. 2) Rotation shaft is horizontal (lateral), and rotation center and the center of gravity of the load are not concentric.</p> <p>* Necessary torque is inertial load only. $T = T_a \times 10$</p> <p>Note) To adjust the speed, margin is necessary for T_f and T_a.</p>		

Effective Torque

Unit: N·m

Model	Size	Operating pressure (MPa)										
		0.1	0.15	0.2	0.3	0.4	0.5	0.6	0.7	0.8	0.9	1.0
CRQ2X	10	—	0.09	0.12	0.18	0.24	0.30	0.36	0.42	—	—	—
	15	—	0.22	0.30	0.45	0.60	0.75	0.90	1.04	—	—	—
	20	0.37	0.55	0.73	1.10	1.47	1.84	2.20	2.57	2.93	3.29	3.66
	30	0.62	0.94	1.25	1.87	2.49	3.11	3.74	4.37	4.99	5.60	6.24
	40	1.06	1.59	2.11	3.18	4.24	5.30	6.36	7.43	8.48	9.54	10.6
MSQX	10	0.18	—	0.36	0.53	0.71	0.89	1.07	1.25	1.42	1.60	1.78
	20	0.37	—	0.73	1.10	1.47	1.84	2.20	2.57	2.93	3.29	3.66
	30	0.55	—	1.09	1.64	2.18	2.73	3.19	3.82	4.37	4.91	5.45
	50	0.93	—	1.85	2.78	3.71	4.64	5.57	6.50	7.43	8.35	9.28

CRQ2X

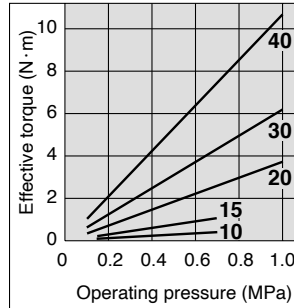

MSQX

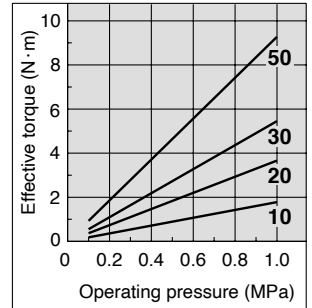

Note 1) Values of operating torque in the above table are representative values, and not guaranteed. Make use of the values as a reference when ordering.

Note 2) Except for cases when an external stopper is used, the holding torque at the operation end is half of the table value.

Kinetic Energy/Rotating Time

In a rotational movement, the kinetic energy of a load may damage the internal parts, even if the required torque for a load is small. Consider the moment of inertia and rotation time before selecting a model.

(For model selection, refer to the moment of inertia and rotation time graph as shown on the below table.)

Allowable kinetic energy and rotation time adjustment range

Set the rotation time, within stable operational guidelines, using the adjustment range specification table as detailed below. When operating at low-speeds which exceed the rotation time adjustment range, use caution as it may result in sticking or malfunction.

Model	Size	Allowable kinetic energy (J)	Stable operational rotation time adjustment range (s/90°)
CRQ2X	10	0.00025	0.7 to 5
	15	0.00039	
	20	0.025	
	30	0.048	
	40	0.081	
MSQX	10	0.007	1 to 5
	20	0.025	
	30	0.048	
	50	0.081	

Model Selection

Select a model based on the moment of inertia and rotation time as shown graph below.

CRQ2X

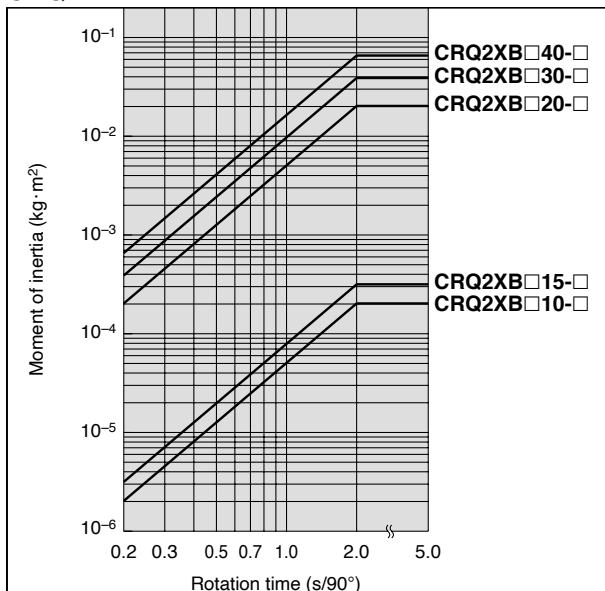

MSQX

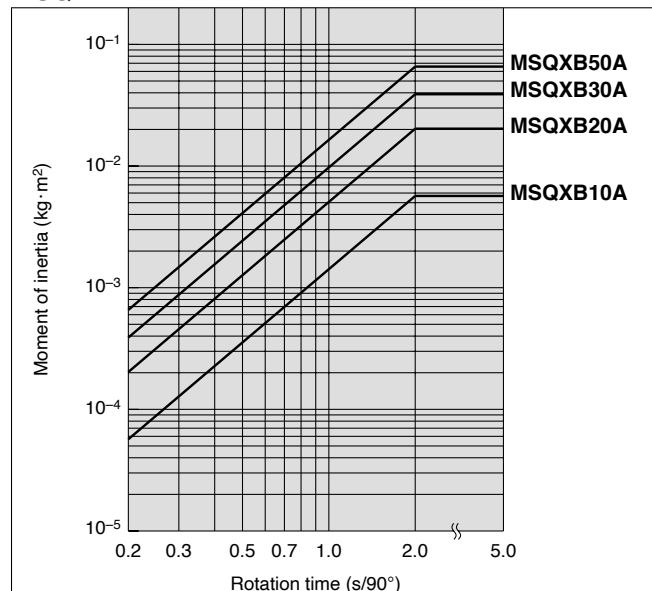

* If the rotation time exceeds 2s per 90°, kinetic energy is calculated with rotation time of 2s per 90°.

Model Selection

Allowable Load

CRQ2X

A load up to the allowable radial/thrust load can be applied provided that a dynamic load is not generated. However, applications which apply a load directly to the shaft should be avoided whenever possible. In order to further improve the operating conditions, a method such as that shown in the drawing on the right side is recommended so that a direct load is not applied to the shaft.

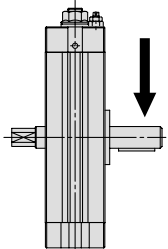
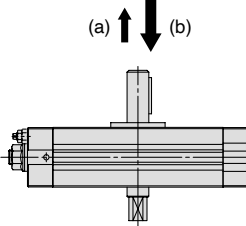
Size			
	Allowable radial load (N)	Allowable thrust load (N)	
		(a)	(b)
10	14.7	7.8	15.7
15	19.6	9.8	19.6
20	49	29.4	49
30	78	49	98
40	98	59	108

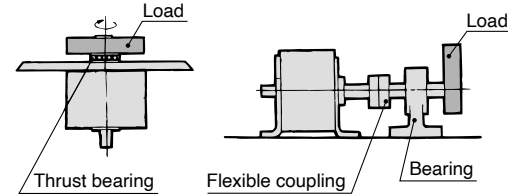

MSQX

Do not allow the load and moment applied to the table to exceed the allowable values shown in the below table. (Operation beyond the allowable values can cause adverse effects on service life, such as play in the table and loss of accuracy.)

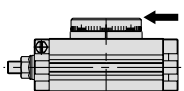
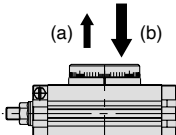
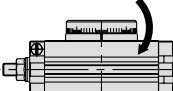
Size				
	Allowable radial load (N)	Allowable thrust load (N)		Allowable moment (N·m)
		(a)	(b)	
10	78	74	78	2.4
20	147	137	137	4.0
30	196	197	363	5.3
50	314	296	451	9.7

Rotary Actuator Technical Data

Air Consumption

Air consumption is the volume of air which is expended by the rotary actuator's reciprocal operation inside the actuator and in the piping between the actuator and the switching valve, etc. This is necessary for selection of a compressor and for calculation of its running cost.

* The air consumption (Q_{CR}) required for one reciprocation of the rotary actuator alone is shown in the below table, and can be used to simplify the calculation.

Formulas

$$Q_{CR} = 2V \times \left(\frac{P + 0.1}{0.1} \right) \times 10^{-3}$$

$$Q_{CP} = 2 \times a \times \ell \times \left(\frac{P}{0.1} \right) \times 10^{-6}$$

$$Q_C = Q_{CR} + Q_{CP}$$

Q_{CR} = Air consumption of rotary actuator	[ℓ (ANR)]
Q_{CP} = Air consumption of tubing or piping	[ℓ (ANR)]
V = Internal volume of rotary actuator	[cm ³]
P = Operating pressure	[MPa]
ℓ = Length of piping	[mm]
a = Internal cross section of piping	[mm ²]
Q_C = Air consumption required for one reciprocation of rotary actuator	[ℓ (ANR)]

When selecting a compressor, it is necessary to choose one which has sufficient reserve for the total air consumption of pneumatic actuators downstream. This is affected by factors such as leakage in piping, consumption by drain valves and pilot valves, etc., and reduction of air volume due to drops in temperature.

Formulas

$$Q_{C2} = Q_C \times n \times \text{Number of actuators} \times \text{Reserve factor}$$

Q_{C2} = Compressor discharge flow rate [ℓ/min (ANR)]

n = Actuator reciprocations per minute

Reserve factor: 1.5 or greater

Internal Cross Section of Tubing and Steel Piping

Nominal size	O.D. (mm)	I.D. (mm)	Internal cross section a (mm ²)
T□0425	4	2.5	4.9
T□0604	6	4	12.6
TU0805	8	5	19.6
T□0806	8	6	28.3
1/8B	—	6.5	33.2
T□1075	10	7.5	44.2
TU1208	12	8	50.3
T□1209	12	9	63.6
1/4B	—	9.2	66.5
TS1612	16	12	113
3/8B	—	12.7	127
T□1613	16	13	133
1/2B	—	16.1	204
3/4B	—	21.6	366
1B	—	27.6	598

Air Consumption

Air consumption: Q_{CR} ℓ (ANR)

Model	Size	Rotation angle (°)	Internal volume V (cm ³)	Operating pressure (MPa)										
				0.1	0.15	0.2	0.3	0.4	0.5	0.6	0.7	0.8	0.9	1.0
CRQ2X	10	90	1.2	—	0.006	0.007	0.009	0.012	0.014	0.016	0.018	—	—	—
		180	2.2	—	0.011	0.013	0.018	0.022	0.026	0.031	0.035	—	—	—
	15	90	2.9	—	0.015	0.017	0.023	0.029	0.035	0.041	0.046	—	—	—
		180	5.5	—	0.028	0.033	0.044	0.055	0.066	0.077	0.088	—	—	—
	20	90	7.1	0.028	0.036	0.043	0.057	0.071	0.085	0.099	0.114	0.128	0.142	0.156
		180	13.5	0.054	0.068	0.081	0.108	0.135	0.162	0.189	0.216	0.243	0.270	0.297
	30	90	12.1	0.048	0.060	0.073	0.097	0.121	0.145	0.169	0.193	0.218	0.242	0.266
		180	23.0	0.092	0.115	0.138	0.184	0.230	0.276	0.322	0.368	0.413	0.459	0.505
40	90	20.6	0.082	0.103	0.123	0.164	0.206	0.247	0.288	0.329	0.370	0.411	0.452	
	180	39.1	0.156	0.195	0.234	0.313	0.391	0.469	0.547	0.625	0.703	0.781	0.859	
MSQX	10	190	6.6	0.026	0.033	0.040	0.053	0.066	0.079	0.092	0.106	0.119	0.132	0.145
	20		13.5	0.054	0.068	0.081	0.108	0.135	0.162	0.189	0.216	0.243	0.270	0.297
	30		20.1	0.080	0.101	0.121	0.161	0.201	0.241	0.281	0.322	0.362	0.402	0.442
	50		34.1	0.136	0.171	0.205	0.273	0.341	0.409	0.477	0.546	0.614	0.682	0.750

Low-Speed Compact Rotary Actuator Rack & Pinion Type

Series **CRQ2X**

Size: 10, 15, 20, 30, 40

How to Order

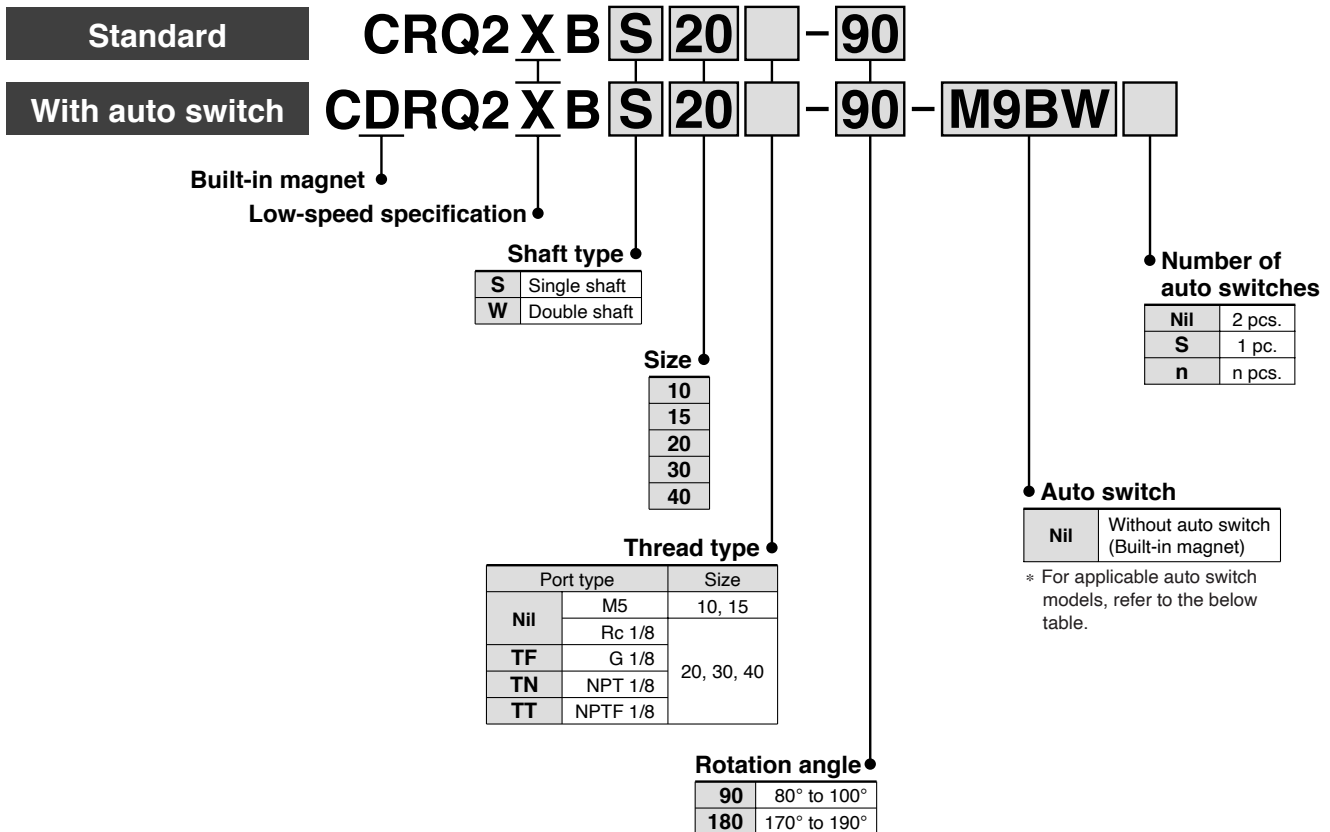

Applicable Auto Switches/Refer to pages 24 through to 27 for further information on auto switches.

Type	Special function	Electrical entry	Indicator light	Wiring (Output)	Load voltage			Auto switch model		Lead wire length (m)*				Applicable load			
					DC	AC	Perpendicular	In-line	0.5 (Nil)	1 (M)	3 (L)	5 (Z)					
Solid state switch	—	Grommet	Yes	3-wire (NPN)	5 V, 12 V	—	M9NV	M9N	●	—	●	○	Relay, PLC				
				3-wire (PNP)			M9PV	M9P	●	—	●	○					
	2-wire			M9BV	M9B		●	—	●	○	—						
	3-wire (NPN)			5 V, 12 V	M9NWV		M9NW	●	●	●	○	IC circuit					
	3-wire (PNP)				M9PWV		M9PW	●	●	●	○	IC circuit					
	2-wire			12 V	M9BWV		M9BW	●	●	●	○	—					
	Water resistant (2-color)**			—	Grommet		Yes	3-wire (NPN)	5 V, 12 V	M9NAV	M9NA	○		○	●	○	IC circuit
								3-wire (PNP)		M9PAV	M9PA	○		○	●	○	IC circuit
								2-wire	12 V	M9BAV	M9BA	○		○	●	○	—
								2-wire	12 V	M9BAV	M9BA	○		○	●	○	—
Reed switch	—	Grommet	No	2-wire	24 V	12 V	100 V or less	A90V	A90	●	—	●	—	IC circuit	Relay, PLC		
			Yes	3-wire (NPN equiv.)	—	5 V	—	A96V	A96	●	—	●	—	IC circuit	—		
				2-wire	24 V	12 V	100 V	A93V	A93	●	—	●	—	—	Relay, PLC		

** Although it is possible to mount water resistant type auto switches, note that the rotary actuator itself is not of water resistant construction.

* Lead wire length symbols: 0.5 m Nil (Example) M9NW
 1 m M M9NWM
 3 m L M9NWL
 5 m Z M9NWZ

- Auto switches marked with "○" are manufactured upon a receipt of order.
- For details about auto switches with pre-wired connector, refer to "SMC Best Pneumatics 2004" Vol. 11 catalog.
- Auto switches are shipped together, (but not assembled).

Low-Speed Compact Rotary Actuator Rack & Pinion Type **Series CRQ2X**

Specifications

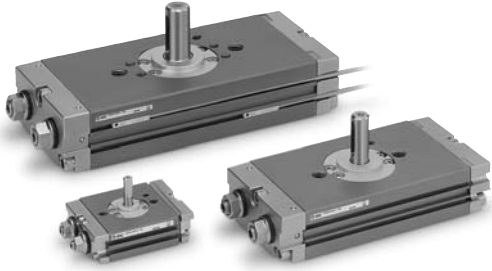

Size	10	15	20	30	40
Fluid	Air (Non-lube)				
Max. operating pressure	0.7 MPa		1 MPa		
Min. operating pressure	0.15 MPa		0.1 MPa		
Ambient and fluid temperature	0° to 60°C (No freezing)				
Cushion	Not attached				
Angle adjustment range	Rotation end $\pm 5^\circ$				
Rotation angle	80° to 100°, 170° to 190°				
Port size	M5 x 0.8		Rc 1/8, G 1/8, NPT 1/8, NPTF 1/8		
Output (N·m)*	0.30	0.75	1.8	3.1	5.3

* Output under the operating pressure at 0.5 MPa. Refer to page 4 for further information.

Allowable Kinetic Energy and Rotation Time Adjustment Range

JIS Symbol

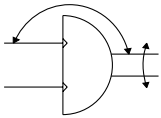

Size	Allowable kinetic energy (J)	Stable operational rotation time adjustment range (s/90°)
10	0.00025	0.7 to 5
15	0.00039	
20	0.025	1 to 5
30	0.048	
40	0.081	

Note) If operated where the kinetic energy exceeds the allowable value, this may cause damage to the internal parts and result in product failure. Please pay special attention to the kinetic energy levels when designing, adjusting and during operation to avoid exceeding the allowable limit.

Weight

Size	Standard weight* (g)	
	90°	180°
10	120	150
15	220	270
20	600	700
30	900	1100
40	1400	1600

* Not including the weight of auto switch.

Series CRQ2X

Rotation Range

When pressurized from the port indicated by the arrow, the shaft will rotate in a clockwise direction.

Rotation angle: 90°

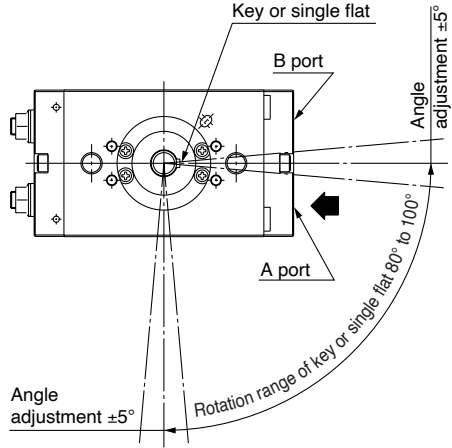

Rotation angle: 180°

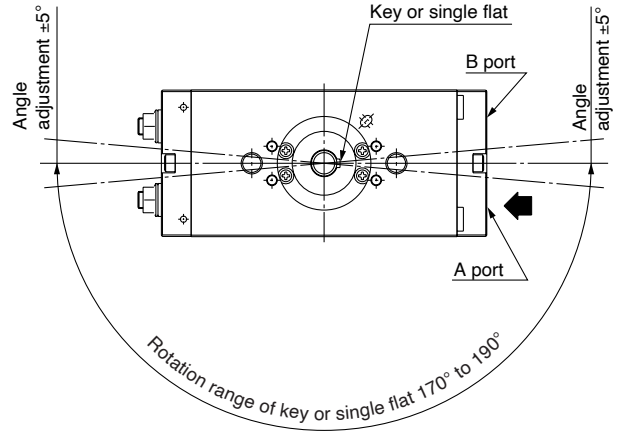

Construction

Standard Size 10/15

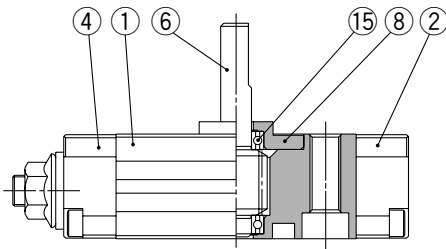
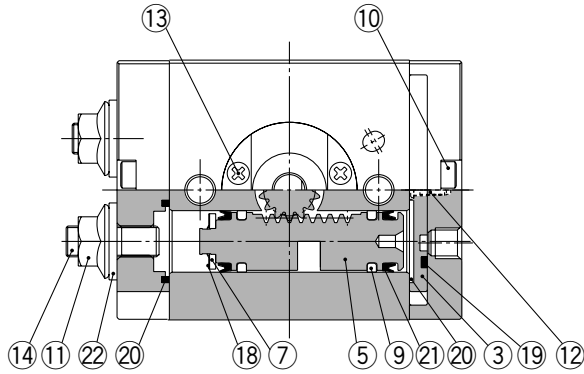

Standard Size 20/30/40

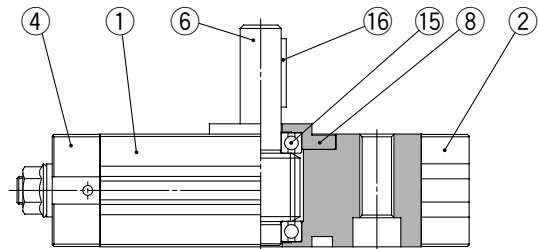
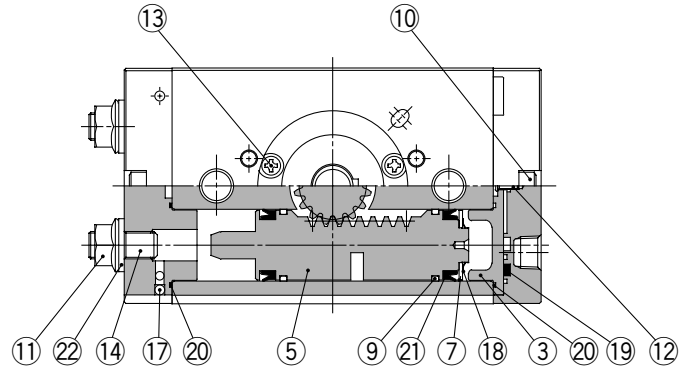

Component Parts

No.	Description	Material
1	Body	Aluminum alloy
2	Cover	Aluminum alloy
3	Plate	Aluminum alloy
4	End cover	Aluminum alloy
5	Piston	Stainless steel
6	Size: 10, 15	Shaft
	Size: 20, 30, 40	
		Stainless steel
		Chrome molybdenum steel
7	Seal retainer	Aluminum alloy
8	Bearing retainer	Aluminum alloy
9	Wear ring	Resin
10	Hexagon socket head cap screw	Stainless steel
11	Hexagon nut with flange	Steel wire
12	Cross recessed screw No. 0	Steel wire

Component Parts

No.	Description	Material
13	Size: 10, 15	Cross recessed screw No. 0
	Size: 20, 30, 40	
		Steel wire
14	Hexagon socket head set screw	Chrome molybdenum steel
15	Bearing	Bearing steel
16	Size: 20, 30, 40 only	Parallel key
		Carbon steel
17	Size: 20, 30, 40 only	Steel ball
		Stainless steel
18	CS-type retaining ring	Stainless steel
19	Seal	NBR
20	Gasket	NBR
21	Piston seal	NBR
22	Seal washer	NBR
23	With auto switch only	Magnet
		—

Replacement Parts

Description	Part no.					Note
	10	15	20	30	40	
Seal kit	P473010-23	P473020-23	P473030-23	P473040-23	P473050-23	A set of above numbers ⑨, ⑰, ⑳, ㉑ and ㉒

Series CRQ2X

Construction

With auto switch
Size 10/15

With auto switch
Size 20/30/40

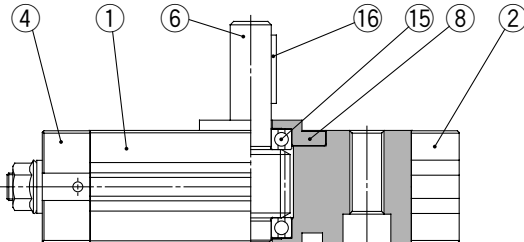
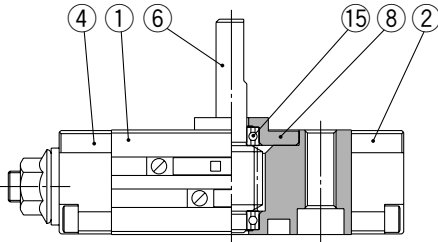
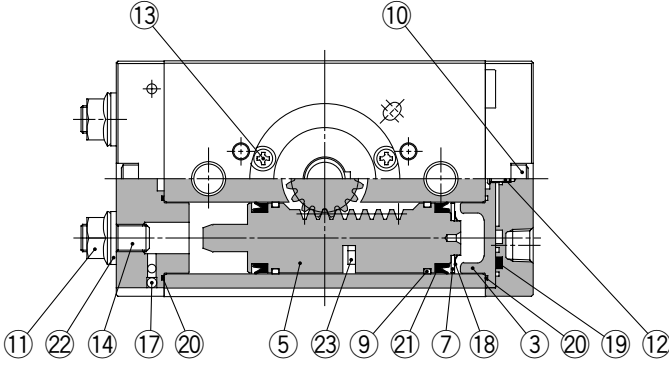
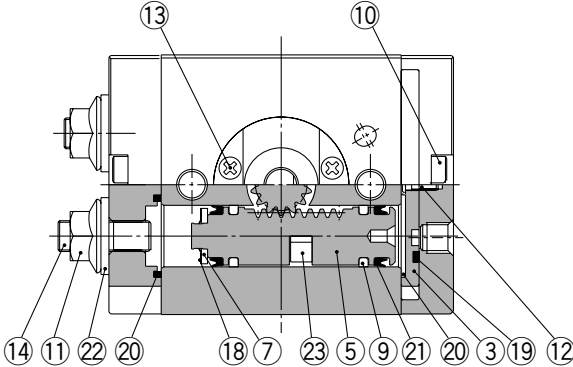

Dimensions

Size 10/15

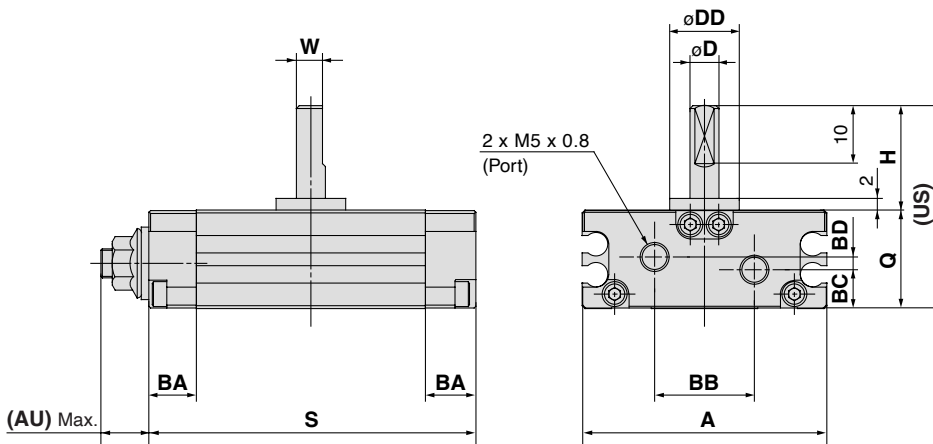
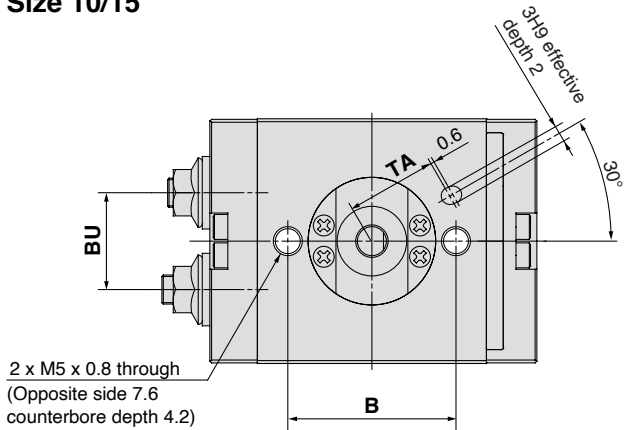

With double shaft

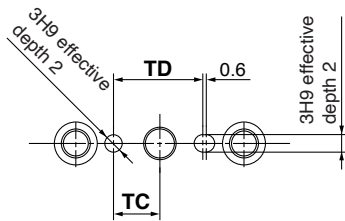
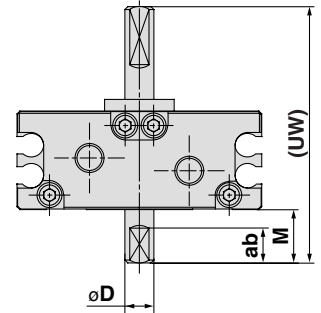

(mm)

Size	Rotation angle	A	AU*	B	BA	BB	BC	BD	BU	D (g6)	DD (h9)	H
10	90°, 180°	42	(8.5)	29	8.5	17	6.7	2.2	16.7	5	12	18
15	90°, 180°	53	(9.5)	31	9	26.4	10.6	—	23.1	6	14	20

Size	Rotation angle	W	Q	S	US	UW	ab	M	TA	TC	TD
10	90°	4.5	17	56	35	44	6	9	15.5	8	15.4
	180°			69							
15	90°	5.5	20	65	40	50	7	10	16	9	17.6
	180°			82							

* The AU dimension is not the dimension at the time of shipment, since its dimension is for adjustment parts.

S: Upper 90°, Lower 180°

Series CRQ2X

Dimensions

Size 20/30/40

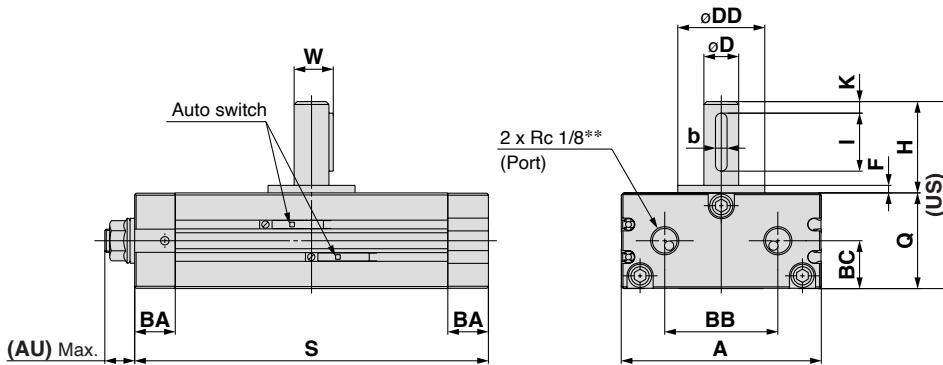
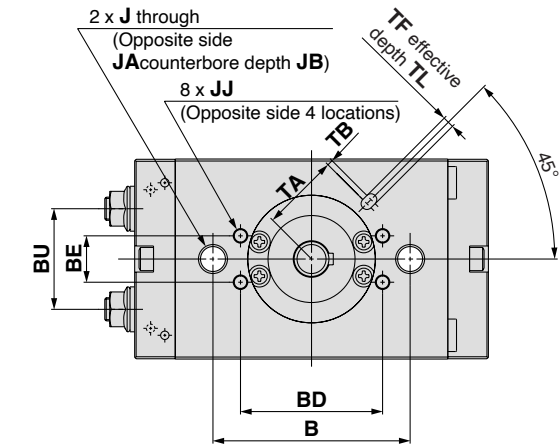

With double shaft

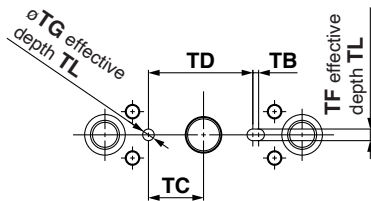
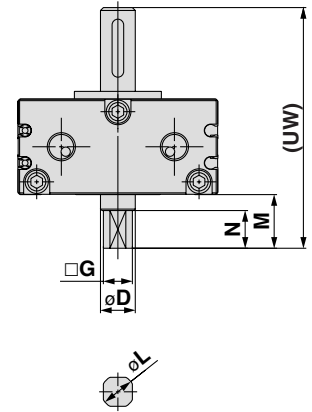

Size	Rotation angle	A	AU*	B	BA	BB	BC	BD	BE	BU	D (g6)	DD (h9)	F	H	J	JA	JB	JJ	K
20	90°, 180°	63	(11)	50	14	34	14.5	—	—	30.4	10	25	2.5	30	M8 x 1.25	11	6.5	—	3
30	90°, 180°	69	(11)	68	14	39	16.5	49	16	34.7	12	30	3	32	M10 x 1.5	14	8.5	M5 x 0.8 depth 6	4
40	90°, 180°	78	(13)	76	16	47	18.5	55	16	40.4	15	32	3	36	M10 x 1.5	14	8.6	M6 x 1 depth 7	5

Size	Rotation angle	Q	S	W	Keyway dimensions		US	TA	TB	TC	TD	TF (H9)	TG (H9)	TL	UW	G	M	N	L
					b	I													
20	90°	29	104	11.5	4 ⁰ _{-0.03}	20	59	24.5	1	13.5	27	4	4	2.5	74	8 ⁰ _{-0.1}	15	11	9.6 ⁰ _{-0.1}
	180°		130																9.6 ⁰ _{-0.1}
30	90°	33	122	13.5	4 ⁰ _{-0.03}	20	65	27	2	19	36	4	4	2.5	83	10 ⁰ _{-0.1}	18	13	11.4 ⁰ _{-0.1}
	180°		153																11.4 ⁰ _{-0.1}
40	90°	37	139	17	5 ⁰ _{-0.03}	25	73	32.5	2	20	39.5	5	5	3.5	93	11 ⁰ _{-0.1}	20	15	14 ⁰ _{-0.1}
	180°		177																14 ⁰ _{-0.1}

* The AU dimension is not the dimension at the time of shipment, since its dimension is for adjustment parts.
 ** In addition to Rc 1/8, G 1/8, NPT 1/8, NPTF 1/8 are also available.

S: Upper 90°, Lower 180°

Unit Used as Flange Mount

The L dimensions of this unit are shown in the below table. When hexagon socket head cap bolt of the JIS standard is used, the head of the bolt will recess into the groove of actuator.

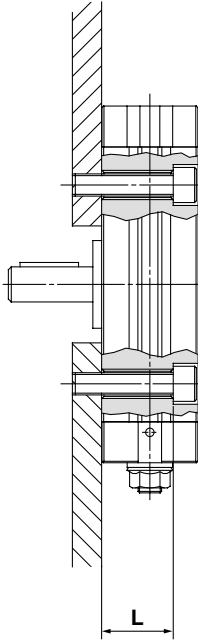

Size	L	Screw
10	13	M4
15	16	M4
20	22.5	M6
30	24.5	M8
40	28.5	M8

Auto Switch Proper Mounting Position (at Rotation End Detection)

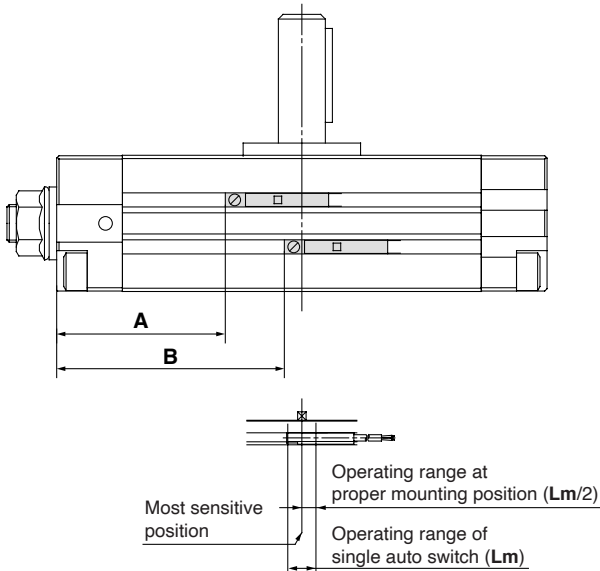

Size	Rotation angle	Reed switch				Solid state switch			
		A	B	Operating angle (° m)	Hysteresis angle	A	B	Operating angle (° m)	Hysteresis angle
10	90°	15	21.5	63°	12°	19	25.5	75°	3°
	180°	18	31			22	35		
15	90°	18.5	27	52°	9°	22.5	31	69°	3°
	180°	22.5	39.5			26.5	43.5		
20	90°	36	48.5	41°	9°	40	52.5	56°	4°
	180°	42	67.5			46	71.5		
30	90°	43	59	32°	7°	47	63	43°	3°
	180°	51	82			55	86		
40	90°	50	69	24°	5°	54	73	36°	4°
	180°	59.5	97.5			63.5	101.5		

Operating angle θ_m : Value of the operating range of single auto switch (Lm) as represented by rotation angle for shaft

Hysteresis angle: Value of the auto switch hysteresis as represented by angle

Note) For actual setting, adjustment shall be made after checking the auto switch operating condition.

Low-Speed Rotary Table Rack & Pinion Type Series **MSQX** Size: 10, 20, 30, 50

How to Order

Basic

MSQX B 10 **A - M9BW**

Low-speed specification

Size

10
20
30
50

Thread type

Port type	Size	
	Nil	M5
Rc 1/8		30, 50
TF	G 1/8	
TN	NPT 1/8	
TT	NPTF 1/8	

With adjustment bolt

Number of auto switches

Nil	2 pcs.
S	1 pc.
n	n pcs.

Auto switch

Nil	Without auto switch (Built-in magnet)
-----	---------------------------------------

* For applicable auto switch models, refer to the below table.

Applicable Auto Switches Refer to pages 24 through to 27 for further information on auto switches.

Type	Special function	Electrical entry	Indicator light	Wiring (Output)	Load voltage			Auto switch model		Lead wire length (m)*				Applicable load	
					DC	AC	Perpendicular	In-line	0.5 (Nil)	1 (M)	3 (L)	5 (Z)			
Solid state switch	—	Grommet	Yes	3-wire (NPN)	5 V, 12 V	—	M9NV	M9N	●	—	●	○	IC circuit	Relay, PLC	
				3-wire (PNP)			M9PV	M9P	●	—	●	○			
				2-wire			M9BV	M9B	●	—	●	○			
	Diagnostic indication (2-color)			24 V	3-wire (NPN)	5 V, 12 V	M9NVV	M9NV	●	●	●	○	IC circuit		
					3-wire (PNP)		M9PVV	M9PV	●	●	●	○			
					2-wire		M9BVV	M9BV	●	●	●	○			
	Water resistant (2-color)**			5 V, 12 V	3-wire (NPN)	5 V, 12 V	M9NAV	M9NA	○	○	●	○	IC circuit		
					3-wire (PNP)		M9PAV	M9PA	○	○	●	○			
					2-wire		M9BAV	M9BA	○	○	●	○			
Reed switch	—	Grommet	No	2-wire	24 V	12 V	100 V or less	A90V	A90	●	—	●	—	IC circuit	Relay, PLC
			Yes	3-wire (NPN equiv.)	—	5 V	—	A96V	A96	●	—	●	—		
				2-wire	24 V	12 V	100 V	A93V	A93	●	—	●	—	—	Relay, PLC

** Although it is possible to mount water resistant type auto switches, note that the rotary actuator itself is not of water resistant construction.

* Lead wire length symbols: 0.5 m Nil (Example) M9NW
 1 m M M9NWM
 3 m L M9NWL
 5 m Z M9NWZ

- Auto switches marked with "○" are manufactured upon a receipt of order.
- For details about auto switches with pre-wired connector, refer to "SMC Best Pneumatics 2004" Vol. 11 catalog.
- Auto switches are shipped together, (but not assembled).

Made to Order → Refer to "SMC Best Pneumatics 2004" Vol. 11 catalog.

- -50 Without indicator light
- -61 Flexible lead wire
- Pre-wired connector

Specifications

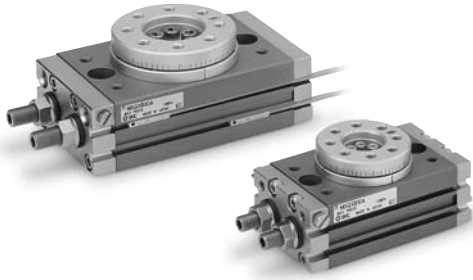

Size		10	20	30	50
Fluid		Air (Non-lube)			
Max. operating pressure		1 MPa			
Min. operating pressure		0.1 MPa			
Ambient and fluid temperature		0° to 60°C (No freezing)			
Cushion		Not attached			
Angle adjustment range		0 to 190°			
Maximum rotation angle		190°			
Port size	End port	M5 x 0.8		Rc 1/8, G 1/8, NPT 1/8, NPTF 1/8	
	Side port	M5 x 0.8			
Output (N·m)*		0.89	1.8	2.7	4.6

* Output under the operating pressure at 0.5 MPa. Refer to page 4 for further information.

JIS Symbol

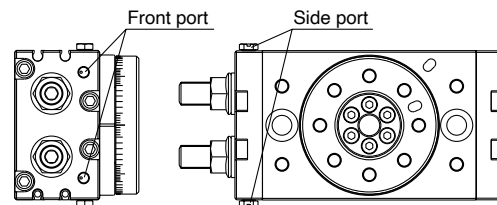
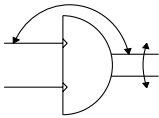

Allowable Kinetic Energy and Rotation Time Adjustment Range

Size	Allowable kinetic energy (J)	Stable operational rotation time adjustment range (s/90°)
10	0.007	1 to 5
20	0.025	
30	0.048	
50	0.081	

Note) If operated where the kinetic energy exceeds the allowable value, this may cause damage to the internal parts and result in product failure. Please pay special attention to the kinetic energy levels when designing, adjusting and during operation to avoid exceeding the allowable limit.

Weight

Size	10	20	30	50
Basic	530	990	1290	2080

* Not including the weight of auto switch.

Series MSQX

Rotation Direction and Rotation Angle

- The rotary table turns in the clockwise direction when the A port is pressurized, and in the counter-clockwise direction when the B port is pressurized.
- By adjusting the adjustment bolt, the rotation end can be set within the range shown in the drawing for the desired rotation angle.

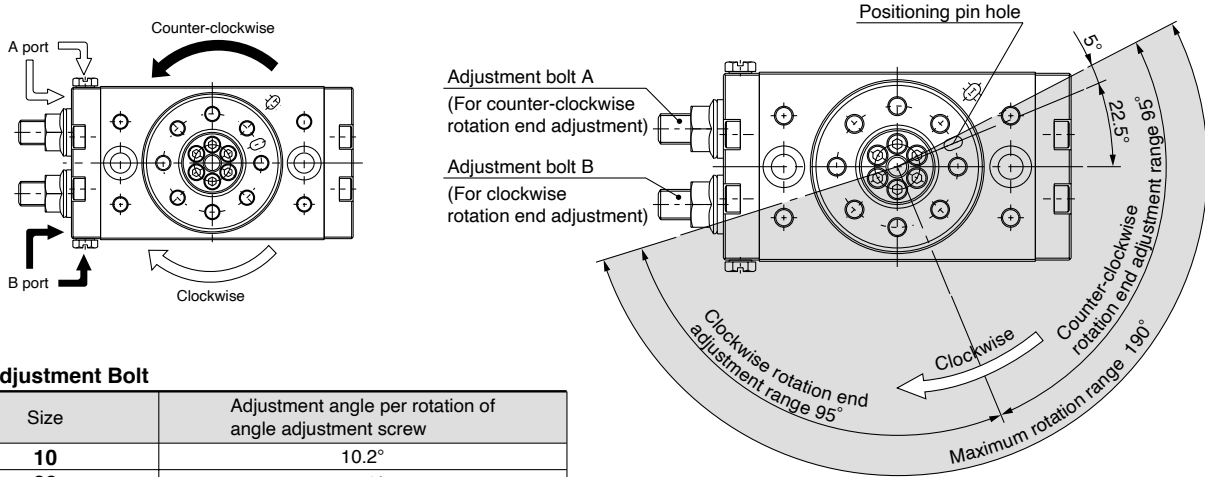

With Adjustment Bolt

Size	Adjustment angle per rotation of angle adjustment screw
10	10.2°
20	7.2°
30	6.5°
50	8.2°

- Note) • The drawing shows the rotation range of the positioning pin hole.
 • The pin hole position in the drawing shows the counter-clockwise rotation end when the adjustment bolts A and B are tightened equally and the rotation is adjusted 180°.

Rotation Angle Range Example

- Various rotation ranges are possible as shown in the drawings below using adjustment bolts A and B. (The drawings also show the rotation ranges of the positioning pin hole.)
- The rotation angle can also be set on a type with inertial absorber.

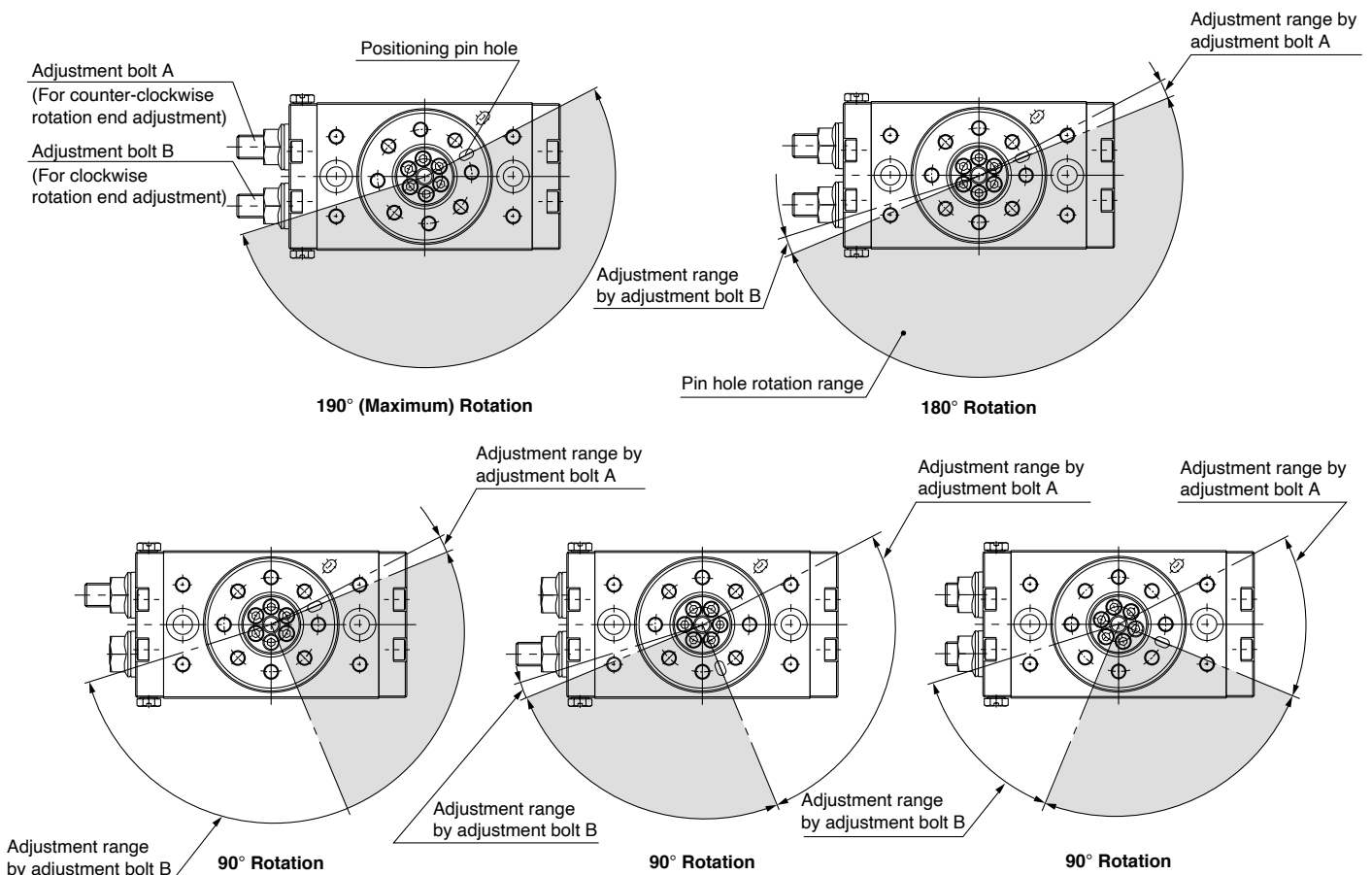
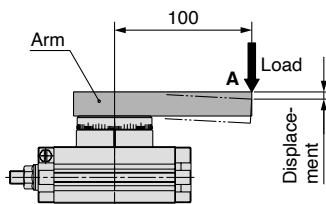
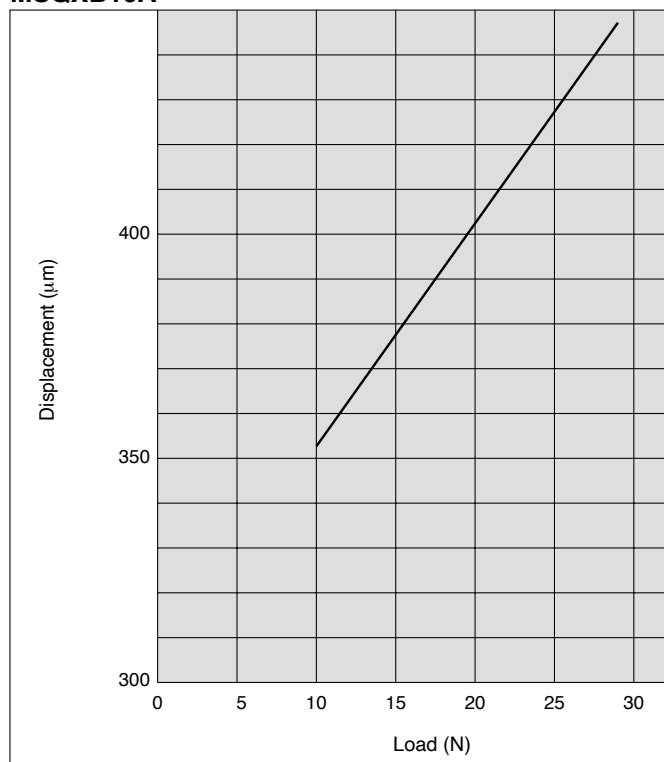

Table Displacement (Reference values)

- The following graphs show the displacement at point A, which is 100 mm apart from the center of rotation, where the load is applied.



MSQXB10A



MSQXB20A

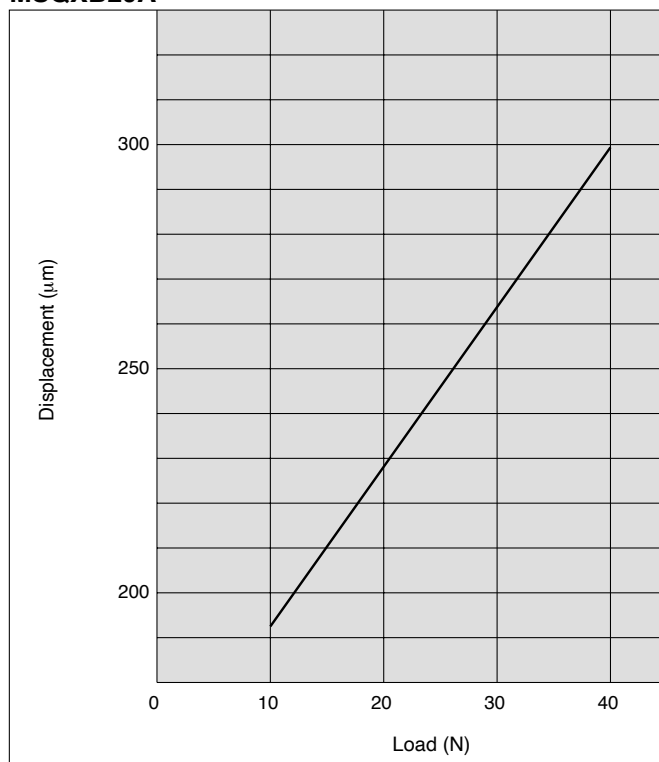

MSQXB30A

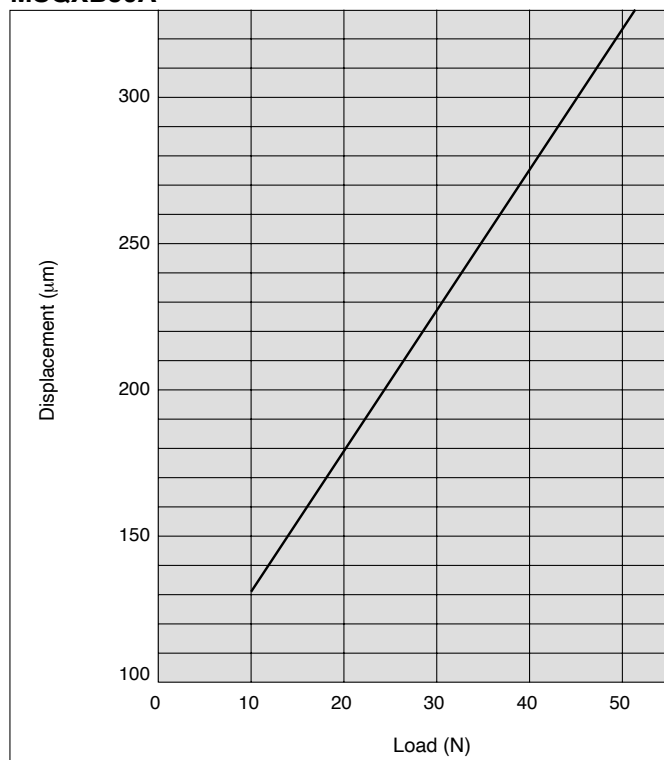

MSQXB50A

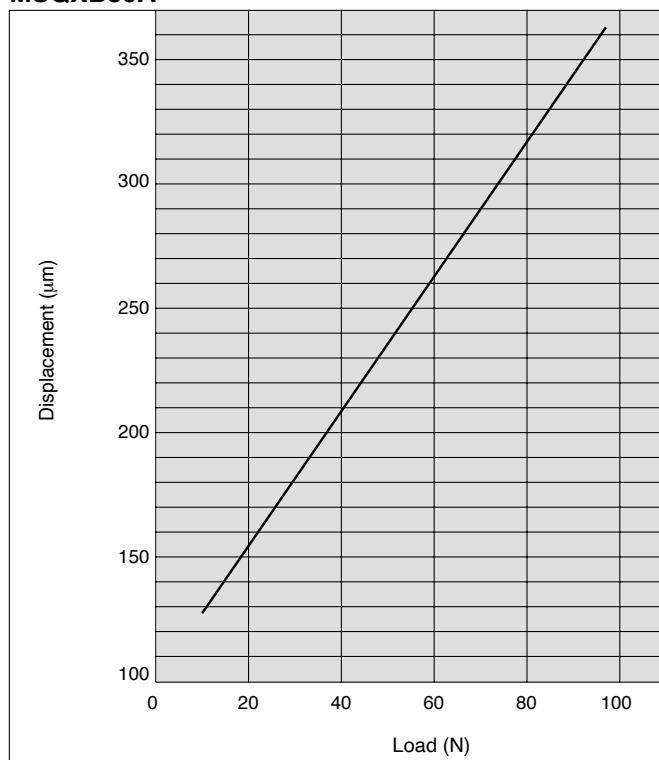

Series MSQX

Construction

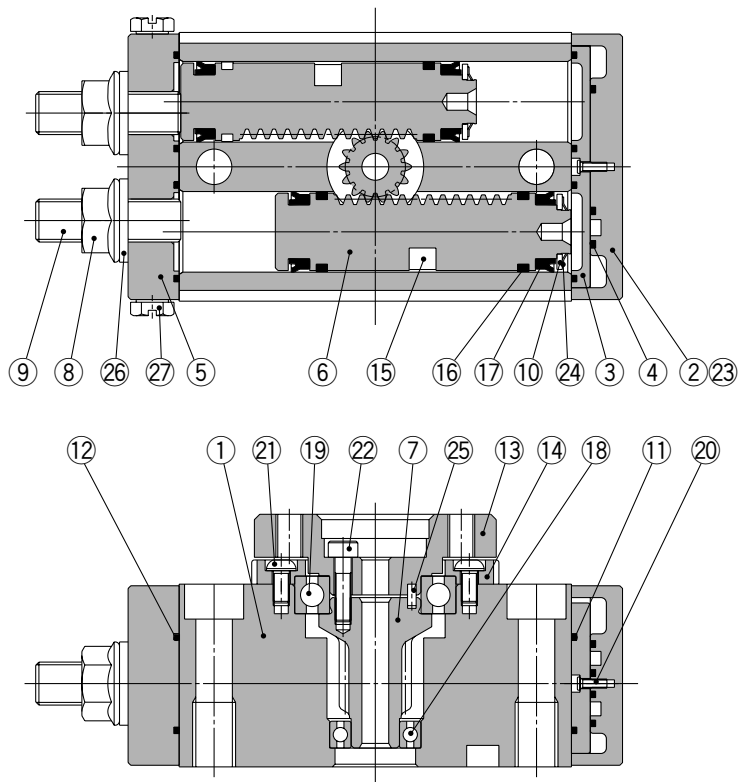

Component Parts

No.	Description	Material
1	Body	Aluminium alloy
2	Cover	Aluminium alloy
3	Plate	Resin
4	Seal	NBR
5	End cover	Aluminium alloy
6	Piston	Stainless steel
7	Pinion	Chrome molybdenum steel
8	Hexagon nut with flange	Steel wire
9	Adjustment bolt	Chrome molybdenum steel
10	Seal retainer	Aluminium alloy
11	Gasket	NBR
12	Gasket	NBR
13	Table	Aluminium alloy
14	Bearing retainer	Aluminium alloy

Component Parts

No.	Description	Material	
15	Magnet	—	
16	Wear ring	Resin	
17	Piston seal	NBR	
18	Deep groove ball bearing	Bearing steel	
19	Deep groove ball bearing	Bearing steel	
20	Cross recessed screw No. 0	Steel wire	
21	Cross recessed screw	Size: 10	Stainless steel
	Low head cap screw	Size: 20 to 50	Chrome molybdenum steel
22	Hexagon socket head cap screw	Stainless steel	
23	Hexagon socket head cap screw	Stainless steel	
24	CS-type retaining ring	Spring steel	
25	Parallel pin	Size: 10 to 50	Carbon steel
26	Seal washer	NBR	
27	Plug	Brass	

Replacement Parts

Description	Part no.				Note
	10	20	30	50	
Seal kit	P523010-20	P523020-20	P523030-20	P523040-20	A set of above numbers (4), (11), (12), (16), (17) and (26)

Series MSQX

Auto Switch Proper Mounting Position (at Rotation End Detection)

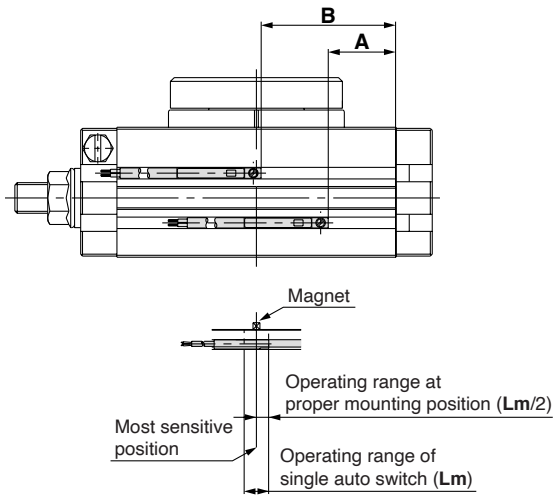

Size	Rotation angle	Reed switch				Solid state switch			
		A	B	Operating angle (θ_m)	Hysteresis angle	A	B	Operating angle (θ_m)	Hysteresis angle
10	190°	17	36	90°	10°	21	40	60°	10°
20	190°	23	50	80°	10°	27	54	50°	10°
30	190°	27	56	65°	10°	31	60	50°	10°
50	190°	33	68	50°	10°	37	72	40°	10°

Operating angle θ_m : Value of the operating range of single auto switch (Lm) as represented by rotation angle for shaft

Hysteresis angle: Value of the auto switch hysteresis as represented by angle

Note) For actual setting, adjustment shall be made after checking the auto switch operating condition.

Series CRQ2X/MSQX

Auto Switch Specifications

Auto Switch Common Specifications

Type	Reed switch	Solid state switch
Leakage current	None	3-wire: 100 μ A or less 2-wire: 0.8 mA or less
Operating time	1.2 ms	1 ms or less
Impact resistance	300 m/s ²	1000 m/s ²
Insulation resistance	50 M Ω or more at 500 VDC Mega (between lead wire and case)	
Withstand voltage	1500 VAC for 1 minute (between lead wire and case)	1000 VAC for 1 minute (between lead wire and case)
Ambient temperature	-10 to 60°C	
Enclosure	IEC60529 standard IP67, JIS C 0920 waterproof construction	
Standard	Conforming to CE Standards	

Lead Wire Length

Lead wire length indication

(Example) D-M9BW **L**

Lead wire length

Nil	0.5 m
M	1 m
L	3 m
Z	5 m

Note 1) Applicable auto switch with 5 m lead wire "Z"

Solid state switch: Manufactured upon receipt of order as standard.

Note 2) To designate solid state switches with flexible specifications, add "-61" after the lead wire length. Flexible cable is used for D-M9□(V), D-M9□W(V), D-M9□A(V) as standard. There is no need to place the suffix -61 to the end of part number.

Note 3) 1 m (M): D-M9□W, D-M9□A(V).

Note 4) Lead wire length tolerance

Lead wire length	Tolerance
0.5 m	±15 mm
1 m	±30 mm
3 m	±90 mm
5 m	±150 mm

Contact Protection Box: CD-P11, CD-P12

<Applicable switch model>

D-A9□(V) type

The above auto switch type does not have a built-in contact protection circuit.

- ① Where the operation load is an inductive load.
- ② Where the wiring length to load is greater than 5 m.
- ③ Where the load voltage is 100 VAC.

Therefore, use a contact protection box with the switch for any of the above cases:

The contact life may be shortened (due to permanent energizing conditions). Since the solid state auto switch is a semiconductor switch which has no contacts, no contact protection box is needed.

- ④ Where the load voltage is 110 VAC.

When the load voltage is increased by more than 10% to the rating of applicable auto switches above, use a contact protection box (CD-P11) to reduce the upper limit of the load current by 10% so that it can be set within the range of the load current range.

Specifications

Part no.	CD-P11		CD-P12
Load voltage	100 VAC	200 VAC	24 VDC
Max. load current	25 mA	12.5 mA	50 mA

* Lead wire length — Switch connection side 0.5 m
Load connection side 0.5 m



Internal Circuit

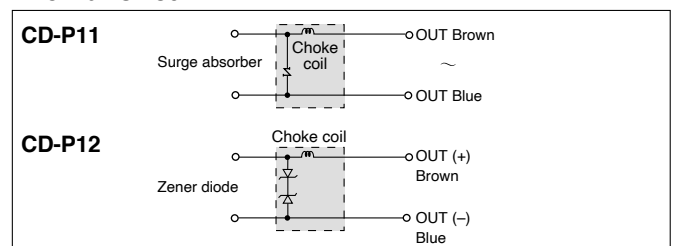

Dimensions

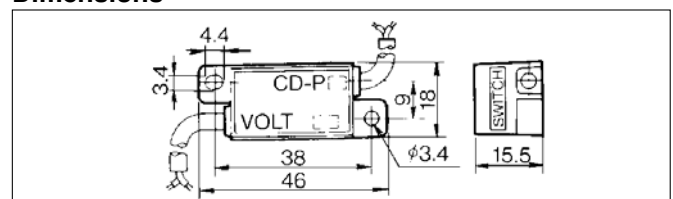

Connection

To connect a switch unit to a contact protection box, connect the lead wire from the side of the contact protection box marked SWITCH to the lead wire coming out of the switch unit. Keep the switch as close as possible to the contact protection box, with a lead wire length of no more than 1 meter.

Auto Switch Connections and Examples

Basic Wiring

Solid state 3-wire, NPN

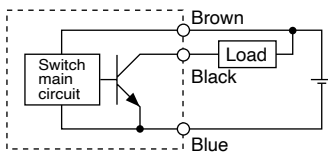

Solid state 3-wire, PNP

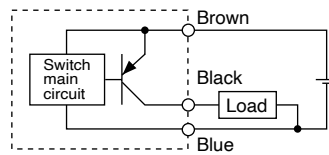

2-wire (Solid state)

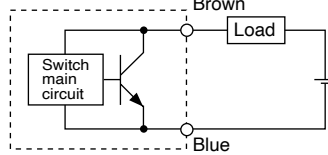

2-wire (Reed)

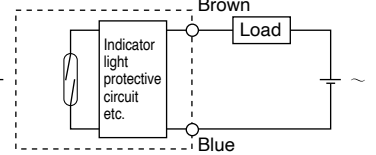

(Power supplies for switch and load are separate.)

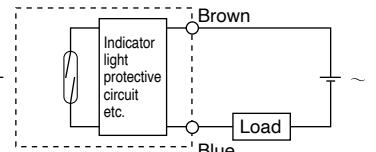
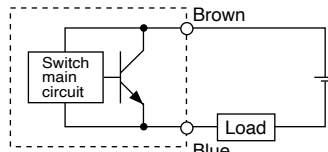
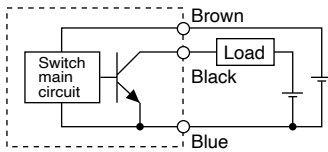

Example of Connection to PLC (Programmable Logic Controller)

• Sink input specification 3-wire, NPN

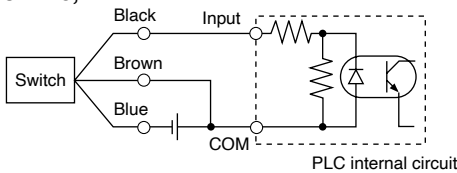

• Source input specification 3-wire, PNP

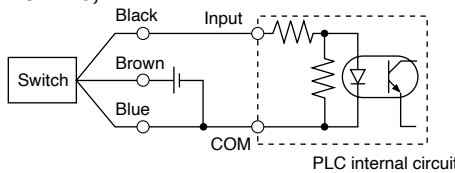

Connect according to the applicable PLC input specifications, since the connection method will vary depending on the PLC input specifications.

2-wire

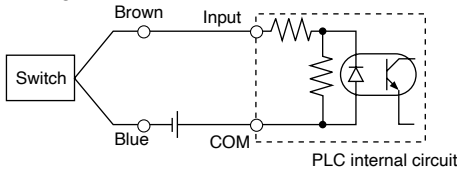

2-wire

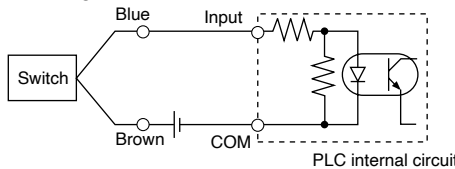

Example of AND (Serial) and OR (Parallel) Connection

• 3-wire

AND connection for NPN output (using relays)

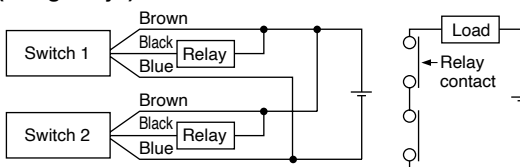

AND connection for NPN output (performed with switches only)

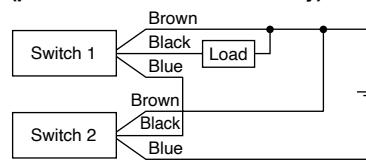

OR connection for NPN output

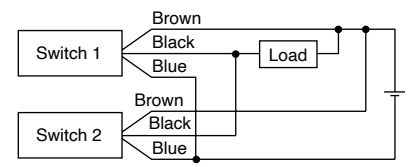

The indicator lights will illuminate when both switches are turned ON.

2-wire with 2-switch AND connection

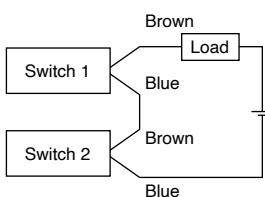

When two switches are connected in series, a load may malfunction because the load voltage will decrease when in the ON state. The indicator lights will illuminate if both of the switches are in the ON state.

2-wire with 2-switch OR connection

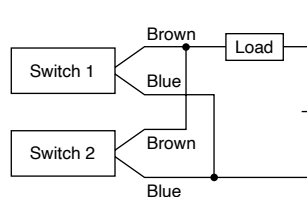

(Solid state)

When two switches are connected in parallel, a malfunction may occur because the load voltage will increase when in the OFF state.

(Reed)

Because there is no current leakage, the load voltage will not increase when turned OFF. However, depending on the number of switches in the ON state, the indicator lights may sometimes dim or not light because of the dispersion and reduction of the current flowing to the switches.

$$\begin{aligned} \text{Load voltage at ON} &= \frac{\text{Power supply voltage}}{\text{Residual voltage}} \times 2 \text{ pcs.} \\ &= \frac{24 \text{ V}}{4 \text{ V}} \times 2 \text{ pcs.} \\ &= 16 \text{ V} \end{aligned}$$

Example: Power supply is 24 VDC.
Internal voltage drop in switch is 4 V.

$$\begin{aligned} \text{Load voltage at OFF} &= \text{Leakage current} \times 2 \text{ pcs.} \\ &\quad \times \text{Load impedance} \\ &= 1 \text{ mA} \times 2 \text{ pcs.} \times 3 \text{ k}\Omega \\ &= 6 \text{ V} \end{aligned}$$

Example: Load impedance is 3 kΩ.
Leakage current from switch is 1 mA.

Reed Switch: Direct Mounting Style

D-A90(V)/D-A93(V)/D-A96(V)

Grommet



Caution

Precautions

Fix the switch with the existing screw installed on the switch body. The switch may be damaged if a screw other than the one supplied is used.

Auto Switch Internal Circuit

D-A90(V)

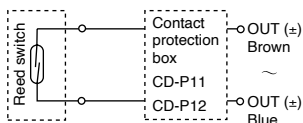

D-A93(V)

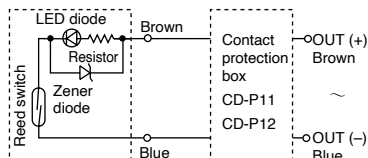

D-A96(V)

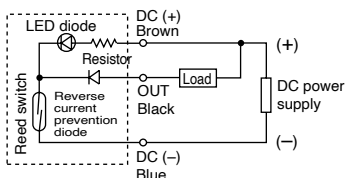

- Note) ① In a case where the operation load is an inductive load.
 ② In a case where the wiring load is greater than 5 m.
 ③ In a case where the load voltage is 100 VAC.

Use the auto switch with a contact protection box in any of the above mentioned cases. (For details about the contact protection box, refer to page 22.)

Auto Switch Specifications

PLC: Programmable Logic Controller

D-A90/D-A90V (Without indicator light)						
Auto switch part no.	D-A90	D-A90V	D-A90	D-A90V	D-A90	D-A90V
Electrical entry direction	In-line	Perpendicular	In-line	Perpendicular	In-line	Perpendicular
Applicable load	IC circuit, Relay, PLC					
Load voltage	24 VAC/DC or less		48 VAC/DC or less		100 VAC/DC or less	
Maximum load current	50 mA		40 mA		20 mA	
Contact protection circuit	None					
Internal resistance	1 Ω or less (including lead wire length of 3 m)					
Standard	Conforming to CE Standards					
D-A93/D-A93V/D-A96/D-A96V (With indicator light)						
Auto switch part no.	D-A93	D-A93V	D-A93	D-A93V	D-A96	D-A96V
Electrical entry direction	In-line	Perpendicular	In-line	Perpendicular	In-line	Perpendicular
Applicable load	Relay, PLC				IC circuit	
Load voltage	24 VDC		100 VAC		4 to 8 VDC	
Load current range and max. load current	5 to 40 mA		5 to 20 mA		20 mA	
Contact protection circuit	None					
Internal voltage drop	D-A93 — 2.4 V or less (to 20 mA)/3 V or less (to 40 mA)				D-A93V — 2.7 V or less	
Indicator light	Red LED illuminates when turned ON.					
Standard	Conforming to CE Standards					

Lead wires

- D-A90(V)/D-A93(V) — Oilproof heavy-duty vinyl cable: $\phi 2.7$, 0.18 mm² x 2 cores (Brown, Blue), 0.5 m
- D-A96(V) — Oilproof heavy-duty vinyl cable: $\phi 2.7$, 0.15 mm² x 3 cores (Brown, Black, Blue), 0.5 m

Note 1) Refer to page 22 for reed switch common specifications.

Note 2) Refer to page 22 for lead wire lengths.

Note 3) If load current is less than 5 mA, the visibility of the indicator light is decreased. If less than 2.5 mA, the light may become invisible. From the point of view of contact output, however, it is not a problem as long as the load current is more than 1 mA.

Weight

Unit: g

Auto switch part no.	D-A90(V)	D-A93(V)	D-A96(V)
Lead wire length (m)	0.5	6	8
	3	30	41

Dimensions

Unit: mm

D-A90/A93/A96

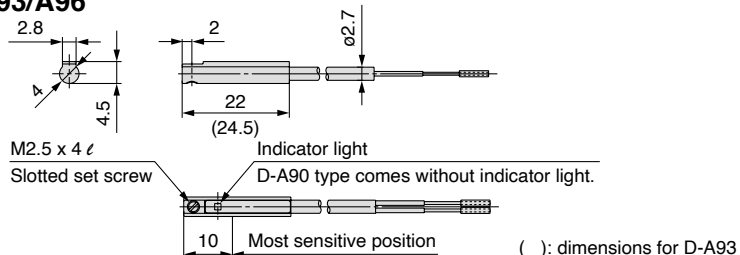

D-A90V/A93V/A96V

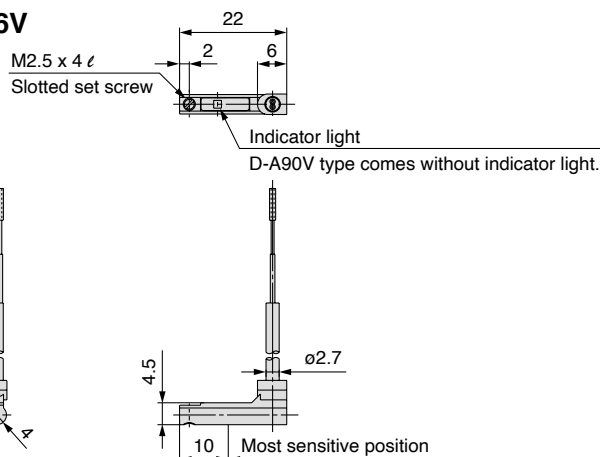

Solid State Switch: Direct Mounting Style D-M9N(V)/D-M9P(V)/D-M9B(V)

Grommet

- 2-wire load current is reduced (2.5 to 40 mA).
- UL certified (style 2844) lead cable is used.
- Flexibility is 1.5 times greater than the conventional model (SMC comparison).
- Using flexible cable as standard spec.
- Brightness of indicator light is 2 times greater than the conventional model (SMC comparison).



⚠ Caution

Precautions

Fix the switch with the existing screw installed on the switch body. The switch may be damaged if a screw other than the one supplied is used.

Auto Switch Internal Circuit

D-M9N(V)

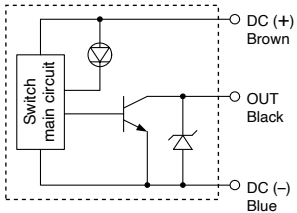

D-M9P(V)

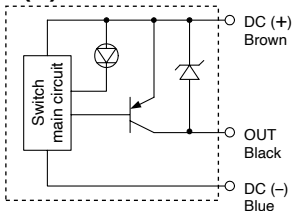

D-M9B(V)

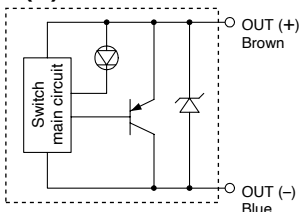

Auto Switch Specifications

PLC: Programmable Logic Controller

D-M9□/D-M9□V (With indicator light)						
Auto switch part no.	D-M9N	D-M9NV	D-M9P	D-M9PV	D-M9B	D-M9BV
Electrical entry direction	In-line	Perpendicular	In-line	Perpendicular	In-line	Perpendicular
Wiring type	3-wire			2-wire		
Output type	NPN		PNP		—	
Applicable load	IC circuit, Relay, PLC				24 VDC relay, PLC	
Power supply voltage	5, 12, 24 VDC (4.5 to 28 V)					—
Current consumption	10 mA or less					—
Load voltage	28 VDC or less		—		24 VDC (10 to 28 VDC)	
Load current	40 mA or less				2.5 to 40 mA	
Internal voltage drop	0.8 V or less					4 V or less
Leakage current	100 μA or less at 24 VDC				0.8 mA or less	
Indicator light	Red LED illuminates when turned ON.					
Standard	Conforming to CE Standards					

- Lead wires — Oilproof heavy-duty vinyl cable: $\phi 2.7 \times 3.2$ ellipse
 D-M9B(V) 0.15 mm² x 2 cores
 D-M9N(V), D-M9P(V) 0.15 mm² x 3 cores

Note 1) Refer to page 22 for solid state switch common specifications.

Note 2) Refer to page 22 for lead wire lengths.

Weight

Unit: g

Auto switch part no.	D-M9N(V)	D-M9P(V)	D-M9B(V)
Lead wire length (m)	0.5	8	7
	3	41	38
	5	68	63

Dimensions

Unit: mm

D-M9□

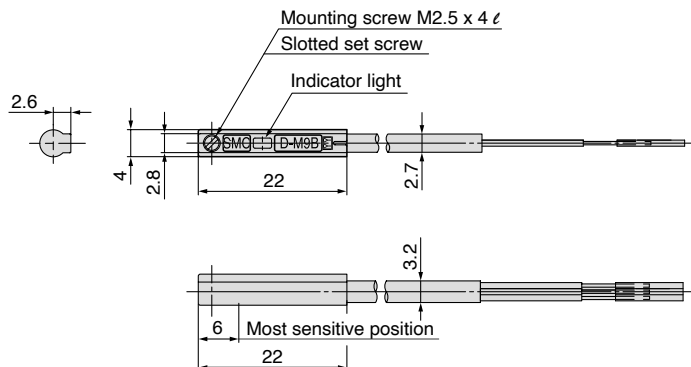

D-M9□V

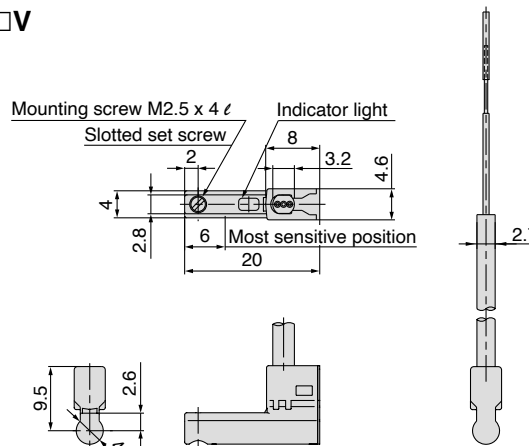

2-Color Indication Solid State Switch: Direct Mounting Style

D-M9NW(V)/D-M9PW(V)/D-M9BW(V)



Grommet

- 2-wire load current is reduced (2.5 to 40 mA).
- UL certified (style 2844) lead cable is used.
- Flexibility is 1.5 times greater than the conventional model (SMC comparison).
- Using flexible cable as standard spec.
- The optimum operating position can be determined by the color of the light. (Red → Green ← Red)
- Brightness of indicator light is 2 times greater than the conventional model (SMC comparison).



Auto Switch Internal Circuit

D-M9NW(V)

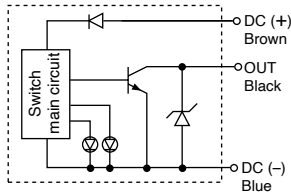

D-M9PW(V)

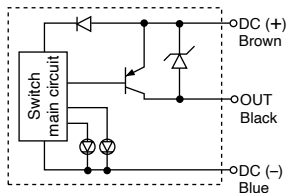

D-M9BW(V)

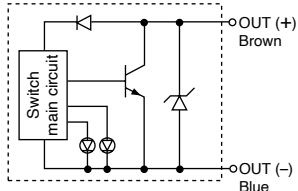

Indicator light / Display method

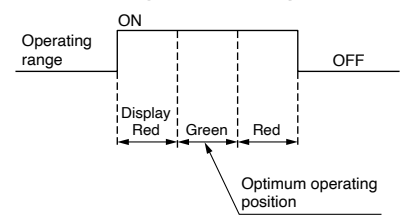

Auto Switch Specifications

PLC: Programmable Logic Controller

D-M9□W/D-M9□WV (With indicator light)						
Auto switch part no.	D-M9NW	D-M9NWV	D-M9PW	D-M9PWV	D-M9BW	D-M9BWV
Electrical entry direction	In-line	Perpendicular	In-line	Perpendicular	In-line	Perpendicular
Wiring type	3-wire			2-wire		
Output type	NPN		PNP		—	
Applicable load	IC circuit, Relay, PLC				24 VDC relay, PLC	
Power supply voltage	5, 12, 24 VDC (4.5 to 28 V)					—
Current consumption	10 mA or less					—
Load voltage	28 VDC or less		—		24 VDC (10 to 28 VDC)	
Load current	40 mA or less				2.5 to 40 mA	
Internal voltage drop	0.8 V or less at 10 mA (2 V or less at 40 mA)				4 V or less	
Leakage current	100 μA or less at 24 VDC				0.8 mA or less	
Indicator light	Operating position Red LED illuminates. Optimum operating position Green LED illuminates.					
Standard	Conforming to CE Standards					

- Lead wires — Oilproof heavy-duty vinyl cable: $\phi 2.7 \times 3.2$ ellipse
D-M9BW(V) 0.15 mm² x 2 cores
D-M9NW(V), D-M9PW(V) 0.15 mm² x 3 cores

Note 1) Refer to page 22 for solid state switch common specifications.
Note 2) Refer to page 22 for lead wire lengths.

Weight

Unit: g

Auto switch part no.	D-M9NW(V)	D-M9PW(V)	D-M9BW(V)
Lead wire length (m)	0.5	8	8
	1	14	14
	3	41	41
	5	68	68

Dimensions

Unit: mm

D-M9□W

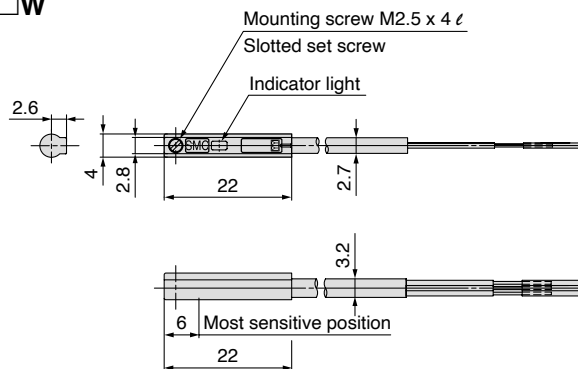

D-M9□WV

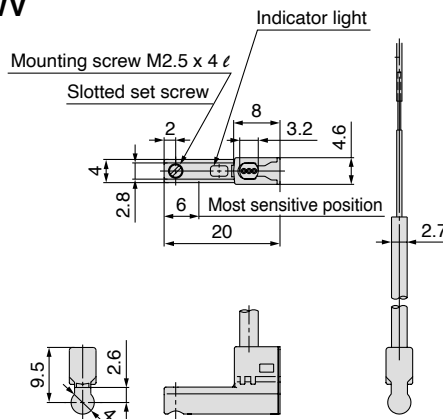

Water Resistant 2-Color Indication Solid State Switch: Direct Mounting Style D-M9NA(V)/D-M9PA(V)/D-M9BA(V)

Grommet

- Water (coolant) resistant type
- 2-wire load current is reduced (2.5 to 40 mA).
- UL certified (style 2844) lead cable is used.
- The optimum operating position can be determined by the color of the light. (Red Green Red)

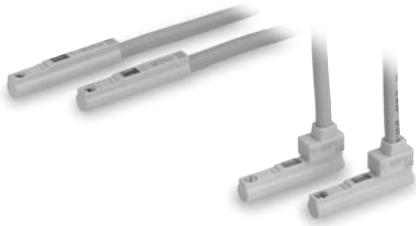

Auto Switch Internal Circuit

D-M9NA(V)

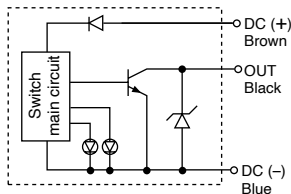

D-M9PA(V)

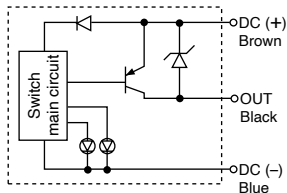

D-M9BA(V)

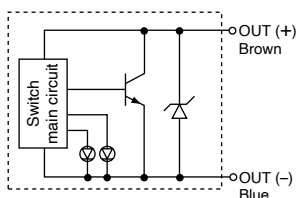

Indicator light / Display method

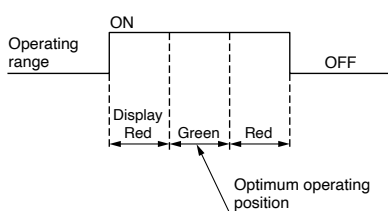

Auto Switch Specifications

PLC: Programmable Logic Controller

D-M9□A/D-M9□AV (With indicator light)						
Auto switch part no.	D-M9NA	D-M9NAV	D-M9PA	D-M9PAV	D-M9BA	D-M9BAV
Electrical entry direction	In-line	Perpendicular	In-line	Perpendicular	In-line	Perpendicular
Wiring type	3-wire			2-wire		
Output type	NPN		PNP		—	
Applicable load	IC circuit, Relay, PLC				24 VDC relay, PLC	
Power supply voltage	5, 12, 24 VDC (4.5 to 28 V)				—	
Current consumption	10 mA or less				—	
Load voltage	28 VDC or less		—		24 VDC (10 to 28 VDC)	
Load current	40 mA or less				2.5 to 40 mA	
Internal voltage drop	0.8 V or less at 10 mA (2 V or less at 40 mA)				4 V or less	
Leakage current	100 μA or less at 24 VDC				0.8 mA or less	
Indicator light	Operating position Red LED illuminates. Optimum operating position Green LED illuminates.					
Standard	Conforming to CE Standards					

- Lead wires — Oilproof heavy-duty vinyl cable: $\phi 2.7 \times 3.2$ ellipse
D-M9BA(V) 0.15 mm² x 2 cores
D-M9NA(V), D-M9PA(V) 0.15 mm² x 3 cores

Note 1) Refer to page 22 for solid state switch common specifications.

Note 2) Refer to page 22 for lead wire lengths.

Weight

Unit: g

Auto switch part no.	D-M9NA(V)	D-M9PA(V)	D-M9BA(V)
Lead wire length (m)	0.5	8	7
	1	14	13
	3	41	38
	5	68	63

Dimensions

Unit: mm

D-M9□A

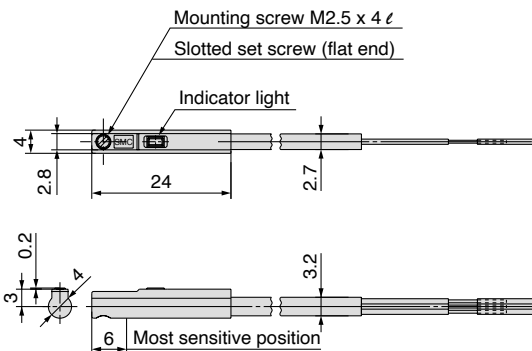

D-M9□AV

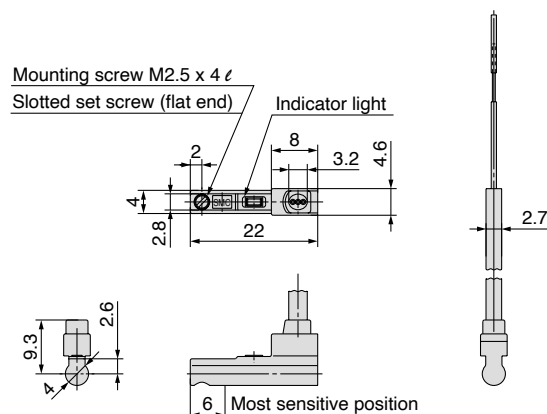

Series MSQX

Made to Order



Please contact SMC for detailed specifications, lead times and prices.

Symbol

With External Stopper

X150/X151/X152/X153

Prevent holding torque from being halved at the rotation end.

How to Order

MSQXB 10 **AX - M9NW** - **X150**

Size | **Port type** | **Auto switch** | **Connection port location and rotation angle**

Size	Port type	Size	Auto switch	Connection port location and rotation angle								
10	Nil	M5	Without auto switch (Built-in magnet)	<table border="1"> <tr> <td>X150</td> <td>Standard, 180°</td> </tr> <tr> <td>X151</td> <td>Standard, 90°</td> </tr> <tr> <td>X152</td> <td>Symmetric type, 180°</td> </tr> <tr> <td>X153</td> <td>Symmetric type, 90°</td> </tr> </table>	X150	Standard, 180°	X151	Standard, 90°	X152	Symmetric type, 180°	X153	Symmetric type, 90°
X150		Standard, 180°										
X151	Standard, 90°											
X152	Symmetric type, 180°											
X153	Symmetric type, 90°											
20	M5	10, 20										
30	Rc 1/8	30, 50										
50	TF		G 1/8									
	TN		NPT 1/8									
	TT	NPTF 1/8										

Specifications

Size	10	20	30	50
Rotation angle	90°, 180°			
Angle adjustment range	Each rotation end $^{+3}_{-5}$			

* Specifications other than the above are the same as standard.

Weight

Size	10	20	30	50
90° spec.	630	1200	1520	2480
180° spec.	600	1140	1450	2370

(g)

* Values not including the auto switch weight.

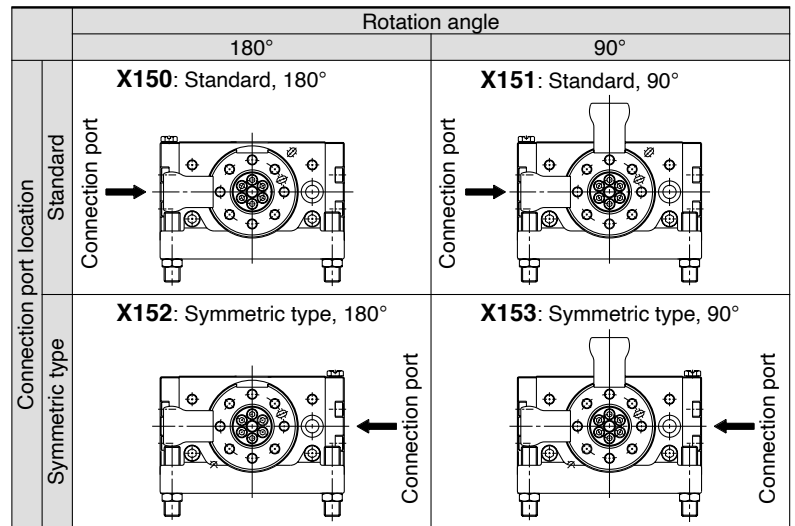

Dimensions

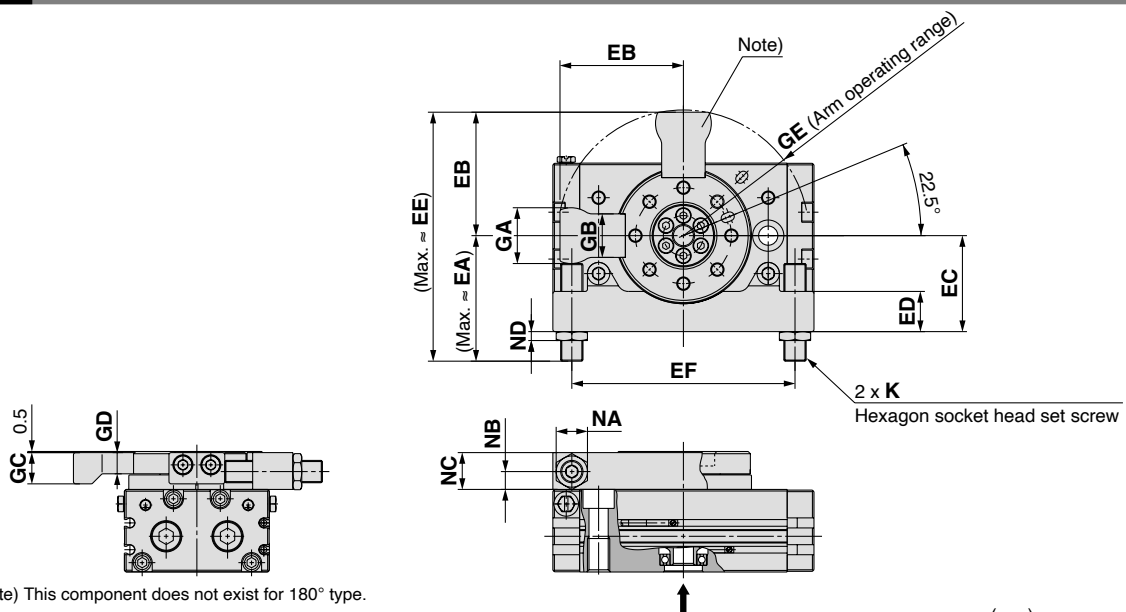

Size	EA	EB	EC	ED	EE	EF	GA	GB	GC	GD	GE	K	NA	NB	NC	ND
10	47.1	44.3	33.5	14	91.4	80	20	15.6	11	7.5	45.2	M8 x 1	10	5.5	12.5	4
20	57.1	55.3	43	18	112.4	100	25	19.5	14	9.5	56.4	M10 x 1	14	8	16.5	4
30	58.4	60.3	46	19.5	118.7	110	27	21.5	14	9.5	61.5	M10 x 1	14	8	16.5	4
50	74.4	71.4	56	22	145.8	130	32	28	18	11.5	72.9	M14 x 1.5	19	8.5	19.5	6



* Dimensions other than the above are the same as standard.



Series CRQ2X/MSQX Safety Instructions

These safety instructions are intended to prevent a hazardous situation and/or equipment damage. These instructions indicate the level of potential hazard by labels of "Caution", "Warning" or "Danger". To ensure safety, be sure to observe ISO 4414 ^{Note 1)}, JIS B 8370 ^{Note 2)} and other safety practices.

■ Explanation of the Labels

Labels	Explanation of the labels
 Danger	In extreme conditions, there is a possible result of serious injury or loss of life.
 Warning	Operator error could result in serious injury or loss of life.
 Caution	Operator error could result in injury ^{Note 3)} or equipment damage. ^{Note 4)}

Note 1) ISO 4414: Pneumatic fluid power – General rules relating to systems

Note 2) JIS B 8370: General Rules for Pneumatic Equipment

Note 3) Injury indicates light wounds, burns and electrical shocks that do not require hospitalization or hospital visits for long-term medical treatment.

Note 4) Equipment damage refers to extensive damage to the equipment and surrounding devices.

■ Selection/Handling/Applications

1. The compatibility of the pneumatic equipment is the responsibility of the person who designs the pneumatic system or decides its specifications.

Since the products specified here are used in various operating conditions, their compatibility for the specific pneumatic system must be based on specifications or post analysis and/or tests to meet the specific requirements. The expected performance and safety assurance are the responsibility of the person who has determined the compatibility of the system. This person should continuously review the suitability of all items specified, referring to the latest catalog information with a view to giving due consideration to any possibility of equipment failure when configuring a system.

2. Only trained personnel should operate pneumatically operated machinery and equipment.

Compressed air can be dangerous if handled incorrectly. Assembly, handling or repair of pneumatic systems should be performed by trained and experienced operators. (Understanding JIS B 8370 General Rules for Pneumatic Equipment, and other safety rules are included.)

3. Do not service machinery/equipment or attempt to remove components until safety is confirmed.

1. Inspection and maintenance of machinery/equipment should only be performed once measures to prevent falling or runaway of the driven objects have been confirmed.
2. When equipment is removed, confirm that safety process as mentioned above. Turn off the supply pressure for this equipment and exhaust all residual compressed air in the system, and release all the energy (liquid pressure, spring, condenser, gravity).
3. Before machinery/equipment is restarted, take measures to prevent quick extension of a cylinder piston rod, etc.

4. If the equipment will be used in the following conditions or environment, please contact SMC first and be sure to take all necessary safety precautions.

1. Conditions and environments beyond the given specifications, or if product is used outdoors.
2. Installation on equipment in conjunction with atomic energy, railway, air navigation, vehicles, medical equipment, food and beverages, recreation equipment, emergency stop circuits, clutch and brake circuits in press applications, or safety equipment.
3. An application which has the possibility of having negative effects on people, property, requiring special safety analysis.
4. If the products are used in an interlock circuit, prepare a double interlock style circuit with a mechanical protection function for the prevention of a breakdown. And, examine the devices periodically if they function normally or not.

■ Exemption from Liability

1. SMC, its officers and employees shall be exempted from liability for any loss or damage arising out of earthquakes or fire, action by a third person, accidents, customer error with or without intention, product misuse, and any other damages caused by abnormal operating conditions.

2. SMC, its officers and employees shall be exempted from liability for any direct or indirect loss or damage, including consequential loss or damage, loss of profits, or loss of chance, claims, demands, proceedings, costs, expenses, awards, judgments and any other liability whatsoever including legal costs and expenses, which may be suffered or incurred, whether in tort (including negligence), contract, breach of statutory duty, equity or otherwise.

3. SMC is exempted from liability for any damages caused by operations not contained in the catalogs and/or instruction manuals, and operations outside of the specification range.

4. SMC is exempted from liability for any loss or damage whatsoever caused by malfunctions of its products when combined with other devices or software.



Series CRQ2X/MSQX Auto Switches Precautions 1

Be sure to read this before handling.

Design and Selection

Warning

1. Confirm the specifications.

Read the specifications carefully and use this product appropriately.

The product may be damaged or malfunction if it is used outside the range of specifications of current load, voltage, temperature or impact. We do not guarantee any damage in any case the product is used outside of the specification range.

2. Pay attention to the length of time that a switch is on at an intermediate stroke position.

When an auto switch is placed at an intermediate position of the stroke and a load is driven at the time the piston passes, the auto switch will operate. However if the speed is too great, the operating time will be shortened and the load may not operate properly. The maximum detectable piston speed is:

$$V \text{ (mm/s)} = \frac{\text{Auto switch operating range (mm)}}{\text{Load operating time (ms)}} \times 1000$$

3. Keep wiring as short as possible.

<Reed switch>

As the length of the wiring to a load gets longer, the rush current at switching ON becomes greater, and this may shorten the product's life. (The switch will stay ON all the time.)

Use a contact protection box when the wire length is 5 m or longer.

<Solid state switch>

Although wire length should not affect switch function, use a wire 100 m or shorter.

If the wiring is longer it will likely increase noise although the length is less than 100 m.

When the wire length is long, we recommend attaching the ferrite core to the both ends of the cable to prevent excess noise.

Since the solid state auto switch is a semiconductor switch which has no contacts, no contact protection box is needed.

4. Do not use a load that generates surge voltage. If a surge voltage is generated, the discharge occurs at the contact, possibly resulting in the shortening of product life.

<Reed switch>

If driving a load such as a relay that generates a surge voltage, use a switch with a built-in contact protection circuit or use a contact protection box.

<Solid state switch>

Although a zener diode for surge protection is connected at the output side of a solid state auto switch, damage may still occur if the surge is applied repeatedly. When a load, such as a relay or solenoid, which generates surge is directly driven, use a type of switch with a built-in surge absorbing element.

5. Cautions for use in an interlock circuit

When an auto switch is used for an interlock signal requiring high reliability, devise a double interlock system to avoid trouble by providing a mechanical protection function, or by also using another switch (sensor) together with the auto switch. Also perform periodic maintenance and confirm proper operation.

6. Do not make any modifications (including exchanging the printed circuit boards) to the product.

It may cause human injuries and accidents.

Caution

1. Use caution when multiple actuators are used and close to each other.

When two or more auto switch actuators are lined up in close proximity to each other, magnetic field interference may cause the switches to malfunction. Maintain a minimum cylinder separation of 40 mm. (When the allowable interval is specified for each cylinder series, use the indicated value.)

Use of a magnetic screen plate (MU-S025) or magnetic screen tape can reduce the interference of magnetic force.

2. Take note of the internal voltage drop of the auto switch.

<Reed switch>

1) Auto switches with an indicator light (Model D-A96(V))

- If auto switches are connected in series as shown below, take note that there will be a large voltage drop because of internal resistance in the light emitting diodes. (Refer to internal voltage drop in the auto switch specifications.) [The voltage drop will be "n" times larger when "n" auto switches are connected.]

Even though an auto switch operates normally, the load may not operate.

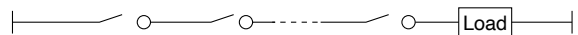

- In the same way, when operating under a specified voltage, although an auto switch may operate normally, the load may not operate. Therefore, the formula below should be satisfied after confirming the minimum operating voltage of the load.

$$\text{Supply voltage} - \text{Internal voltage drop of switch} > \text{Minimum operating voltage of load}$$

2) If the internal resistance of a light emitting diode causes a problem, select a switch without an indicator light (Model D-A90).

<Solid state switch>

3) Generally, the internal voltage drop will be greater with a 2-wire solid state auto switch than with a reed switch. Take the same precautions as in 1).

Also, note that a 12 VDC relay is not applicable.



Series CRQ2X/MSQX

Auto Switches

Precautions 2

Be sure to read this before handling.

Design and Selection

⚠ Caution

3. Pay attention to leakage current.

<Solid state switch>

With a 2-wire solid state auto switch, current (leakage current) flows to the load to operate the internal circuit even when in the OFF state.

$$\text{Operating current of load (OFF condition)} > \text{Leakage current}$$

If the criteria given in the above formula are not met, it will not reset correctly (stays ON). Use a 3-wire switch if this specification will not be satisfied.

Moreover, leakage current flow to the load will be “n” times larger when “n” auto switches are connected in parallel.

4. Ensure sufficient clearance for maintenance activities.

When designing an application, be sure to allow sufficient clearance for maintenance and inspections.

5. Minimum stroke for auto switch mounting

The minimum stroke value for mounting one or two auto switches is obtained when the switch can detect at the cylinder stroke ends.

However, even if the switch is mounted at the proper position within the minimum stroke range, it may not be able to detect when the piston stops in the middle of the stroke due to a stopper, etc. It may also turn on in the middle of a stroke.

6. When multiple auto switches are required.

“n” indicates the number of switch which can be physically mounted. Detection intervals depends on the switch mounting structure and set position therefore some required interval and set positions may not be available.

7. Limitations of detectable positioning

When using certain mounting brackets, the surface and position where an auto switch can be mounted maybe restricted due to physical interference (bottom side of foot bracket etc.). Please select the set position of the auto switch so that it does not interfere with the mounting bracket of the cylinder (trunnion or support ring etc.).

8. Use the cylinder and switch in proper combination.

The auto switch is pre-adjusted to activate properly for an auto-switch-capable SMC cylinder.

If the auto switch is mounted improperly, used for another brand of cylinder or used after the alternation of the machine installation, the switch may not activate properly.

Mounting and Adjustment

⚠ Warning

1. Operating manual

Install the products and operate them only after reading the operating manual carefully and understanding its contents. Also keep the manual where it can be referred to as necessary.

2. Do not drop or bump.

Do not drop, bump or apply excessive impacts (300 m/s² or more for reed switches and 1000 m/s² or more for solid state switches) while handling. Although the body of the auto switch may not be damaged, the inside of the auto switch could be damaged and cause a malfunction.

3. Mount auto switches using the proper fastening torque.

When a switch is tightened beyond the range of fastening torque, the mounting screws, auto switches, auto switch mounting bracket, etc. may be damaged. On the other hand, tightening below the range of fastening torque may allow the switch to slip out of position. (Refer to auto switch mounting for each series regarding auto switch mounting, moving, and fastening torque, etc.)

4. Mount an auto switch at the center of the operating range.

Adjust the mounting position of an auto switch so that the piston stops at the center of the operating range (the range in which a switch is ON). (The mounting position shown in a catalog indicates the optimum position at stroke end.) If mounted at the end of the operating range (around the borderline of ON and OFF), operation will be unstable or the service life will be shortened.

<D-M9□>

When the auto switch is used to replace old series auto switch, it may not activate depending on operating condition because of its shorter operating range.

Such as

- Application where the stop position of actuator may vary and exceed the operating range of the auto switch, for example, pushing, pressing, clamping operation, etc.
- Application where the auto switch is used for detecting an intermediate stop position of the actuator. (In this case the detecting time will be reduced.)

In these applications, set the auto switch to the center of the required detecting range.

5. Secure the space for maintenance.

When installing the products, please allow access for maintenance.

⚠ Caution

1. Do not carry an actuator by the auto switch lead wires.

Never carry a cylinder (actuator) by its lead wires. This may not only cause broken lead wires, but it may cause internal elements of the auto switch to be damaged by the stress.

2. Fix the auto switch with appropriate screw installed on the auto switch body. If using other screws, auto switch may be damaged.



Series CRQ2X/MSQX Auto Switches Precautions 3

Be sure to read this before handling.

Wiring

Warning

1. Confirm proper insulation of wiring.

Be certain that there is no faulty wiring insulation (contact with other circuits, ground fault, improper insulation between terminals, etc.). Damage may occur due to excess current flow into a switch.

2. Do not wire with power lines or high-voltage lines.

Wire separately from power lines or high-voltage lines, avoiding parallel wiring or wiring in the same conduit with these lines. Control circuits, including auto switches, may malfunction due to noise from these other lines.

Caution

1. Avoid repeatedly bending or stretching lead wires.

Broken lead wires will result from applying bending stress or stretching force to the lead wires.

Stress and tensile force applied to the connection between the cable and switch increases the possibility of disconnection.

Fix the cable in the middle so that it is not movable in the area where it connects with the switch.

2. Be sure to connect the load before power is applied.

<2-wire type>

If the power is turned ON when an auto switch is not connected to a load, the switch will be instantly damaged because of excess current.

It is the same as when the 2-wire brown cord (+, output) is directly connected to the (+) power supply terminal.

3. Do not allow short circuit of loads.

<Reed switch>

If the power is turned ON with a load in a short circuited condition, the switch will be instantly damaged because of excess current flow into the switch.

<Solid state switch>

Model D-M9□(V) except D-M9□W(V) and all models of PNP output type switches do not have built-in short circuit prevention circuits. If loads are short circuited, the switches will be instantly damaged, as in the case of reed switches.

Take special care to avoid reverse wiring with the power supply line (brown) and the output line (black) on 3-wire type switches.

Caution

4. Avoid incorrect wiring.

<Reed switch>

A 24 VDC switch with indicator light has polarity. The brown lead wire is (+) and the blue lead wire or the second terminal are (-).

1) If connections are reversed, a switch will operate, however, the light emitting diode will not light up.

Also note that a current greater than that specified will damage a light emitting diode and it will no longer operate.

Applicable models:

D-A93, D-A54

<Solid state switch>

1) If connections are reversed on a 2-wire type switch, the auto switch will not be damaged if protected by a protection circuit, but the switch will always stay in an ON state.

However, it is still necessary to avoid reversed connections, since the auto switch could be damaged by a load short circuit in this condition.

2) If connections are reversed (power supply line + and power supply line -) on a 3-wire type switch, the switch will be protected by a protection circuit. However, if the power supply line (+) is connected to the blue wire and the power supply line (-) is connected to the black wire, the auto switch will be damaged.

<D-M9□>

The D-M9□ does not have built-in short circuit protection circuit. Be aware that if the power supply connection is reversed (e.g. (+) power supply wire and (-) power supply wire connection is reversed), the auto switch will be damaged.

5. When the cable sheath is stripped, confirm the stripping direction. The insulator may be split or damaged depending on the direction. (D-M9□ only)

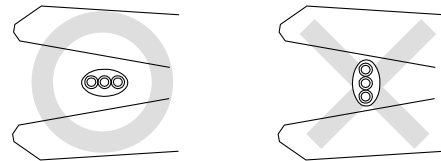

Recommended Tool

Model name	Model no.
Wire stripper	D-M9N-SWY

* Stripper for a round cable (ø2.0) can be used for a 2-wire type cable.

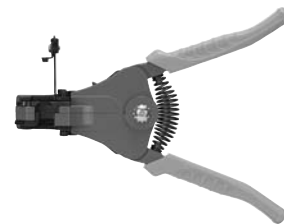



Series CRQ2X/MSQX Auto Switches Precautions 4

Be sure to read this before handling.

Operating Environment

⚠ Warning

- 1. Never use in an atmosphere of explosive gases.**

The construction of auto switches is not intended to prevent explosion. Never use in an atmosphere with an explosive gas since this may cause a serious explosion.
- 2. Do not use in an area where a magnetic field is generated.**

Auto switches will malfunction or magnets inside actuators will become demagnetized.
- 3. Do not use in an environment where the auto switch will be continually exposed to water.**

Although switches, satisfy IEC standard IP67 construction (JIS C 0920: waterproof construction), do not use switches in applications where continually exposed to water splash or spray. Poor insulation or swelling of the potting resin inside auto switches may cause malfunction.
- 4. Do not use in an environment with oil or chemicals.**

Consult with SMC if auto switches will be used in an environment with coolant, cleaning solvent, various oils or chemicals. If auto switches are used under these conditions for even a short time, they may be adversely affected by improper insulation, malfunction due to swelling of the potting resin, or hardening of the lead wires.
- 5. Do not use in an environment with temperature cycles.**

Consult with SMC if switches are used where there are temperature cycles other than normal temperature changes, as they may be adversely affected internally.
- 6. Do not use in an environment where there is excessive impact shock.**

<Reed switch>
When excessive impact (300 m/s² or more) is applied to a reed switch during operation, the contact point will malfunction and generate or cut off a signal momentarily (1 ms or less). Consult with SMC regarding the need to use a solid state switch depending upon the environment.
- 7. Do not use in an area where surges are generated.**

<Solid state switch>
When there are units (solenoid type lifter, high-frequency induction furnace, motor, radio equipment etc.) which generate large surges or electromagnetic waves in the area around actuators with solid state auto switches, this may cause deterioration or damage to the auto switches. Avoid sources of surge generation and crossed lines.

⚠ Caution

- 1. Avoid accumulation of iron debris or close contact with magnetic substances.**

When a large amount of ferrous debris such as machining chips or spatter is accumulated, or a magnetic substance (something attracted by a magnet) is brought into close proximity with an auto switch actuator, it may cause the auto switch (actuator) to malfunction due to a loss of the magnetic force inside the actuator.
- 2. Consult with SMC concerning water resistance, elasticity of lead wires, usage at welding sites, etc.**
- 3. Do not use in direct sunlight.**
- 4. Do not mount the product in locations where it is exposed to radiant heat.**

Maintenance

⚠ Warning

- 1. Perform the following maintenance periodically in order to prevent possible danger due to unexpected auto switch malfunction.**
 - 1) Securely tighten auto switch mounting screws.
If screws become loose or the mounting position is dislocated, retighten them after readjusting the mounting position.
 - 2) Confirm that there is no damage to lead wires.
To prevent faulty insulation, replace auto switches or repair lead wires, etc., if damage is discovered.
 - 3) Confirm the lighting of the green light on the 2-color indicator type auto switch.
Confirm that the green LED is on when stopped at the established position. If the red LED is on, the mounting position is not appropriate. Readjust the mounting position until the green LED lights up.
- 2. Maintenance procedures are outlined in the operation manual.**

Not following proper procedures could cause the product to malfunction and could lead to damage to the equipment or machine.
- 3. Removal of equipment, and supply/exhaust of compressed air**

Before any machinery or equipment is removed, first ensure that the appropriate measures are in place to prevent the fall or erratic movement of driven objects and equipment, then cut off the electric power and reduce the pressure in the system to zero. Only then should you proceed with the removal of any machinery and equipment.
When machinery is restarted, proceed with caution after confirming that appropriate measures are in place to prevent actuators from sudden movement.



Series **CRQ2X/MSQX** Specific Product Precautions

Be sure to read this before handling.

Selection

Caution

1. **Changes in speed occur in applications in which there are changes to the load during operation, such as the load being lifted (lowered) against gravity.**
2. **The purpose of this product is stable rotation at low-speed.**
It does not provide any function to cushion the impact at the operation start or end.
3. **Speed may vary at the rotation end depending on operating conditions. (This phenomenon can be avoided by using the external stopper.)**

Air Supply

Caution

1. **Do not use at dew point of -60°C or lower.**
Operation at dew point of -60°C or lower may adversely affect the lubricant used inside and can lead to operation failure.



SMC'S GLOBAL MANUFACTURING, DISTRIBUTION AND SERVICE NETWORK

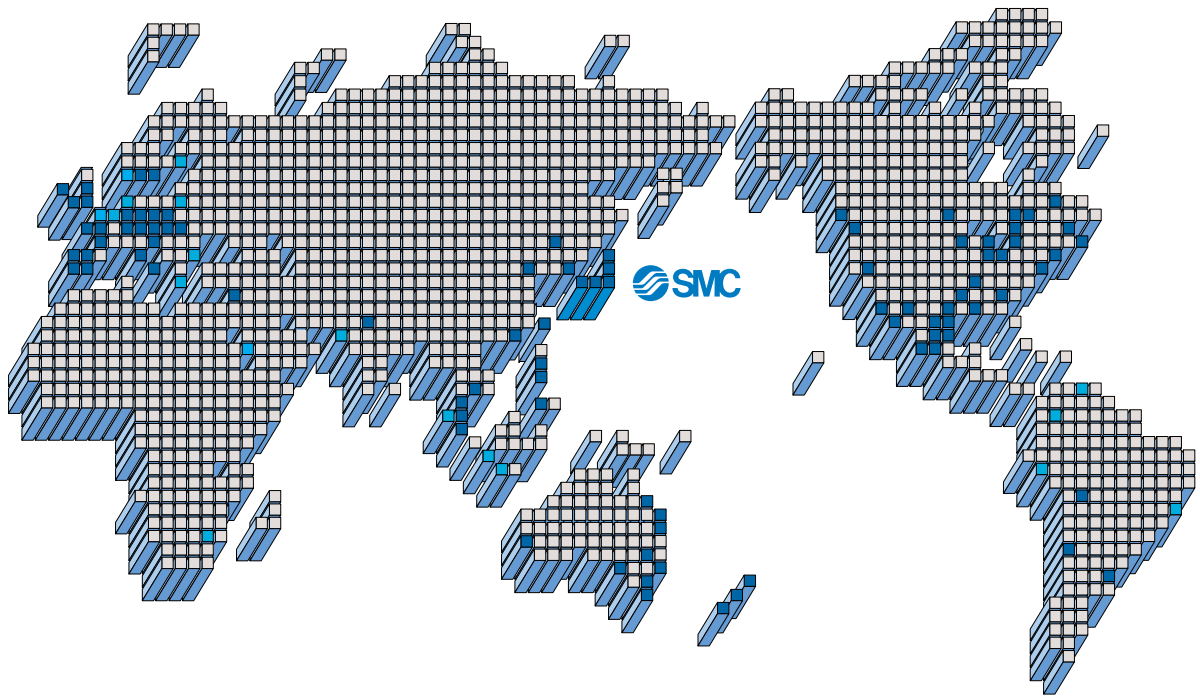

EUROPE

AUSTRIA

SMC Pneumatik GmbH

BELGIUM

SMC Pneumatics N.V./S.A.

BULGARIA

SMC Industrial Automation Bulgaria EOOD

CROATIA

SMC Industrijska automatika d.o.o.

CZECH REPUBLIC

SMC Industrial Automation CZ s.r.o.

DENMARK

SMC Pneumatik A/S

ESTONIA

SMC Pneumatics Estonia OÜ

FINLAND

SMC Pneumatics Finland OY

FRANCE

SMC Pneumatique SA

GERMANY

SMC Pneumatik GmbH

GREECE

SMC Hellas EPE

HUNGARY

SMC Hungary Ipari Automatizálási Kft.

IRELAND

SMC Pneumatics (Ireland) Ltd.

ITALY

SMC Italia S.p.A.

LATVIA

SMC Pnuematics Latvia SIA

LITHUANIA

SMC Pneumatics Lietuva, UAB

NETHERLANDS

SMC Pneumatics BV.

NORWAY

SMC Pneumatics Norway A/S

POLAND

SMC Industrial Automation Polska Sp.z.o.o.

ROMANIA

SMC Romania s.r.l.

RUSSIA

SMC Pneumatik LLC.

SLOVAKIA

SMC Priemyselná automatizácia, s.r.o.

SLOVENIA

SMC INDUSTRIJSKA AVTOMATIKA d.o.o.

SPAIN/PORTUGAL

SMC España, S.A.

SWEDEN

SMC Pneumatics Sweden AB

SWITZERLAND

SMC Pneumatik AG.

UK

SMC Pneumatics (U.K.) Ltd.

ASIA

CHINA

SMC (China) Co., Ltd.

HONG KONG

SMC Pneumatics (Hong Kong) Ltd.

INDIA

SMC Pneumatics (India) Pvt. Ltd.

INDONESIA

PT. SMC Pneumatics Indonesia

MALAYSIA

SMC Pneumatics (S.E.A.) Sdn. Bhd.

PHILIPPINES

SHOKETSU-SMC Corporation

SINGAPORE

SMC Pneumatics (S.E.A.) Pte. Ltd.

SOUTH KOREA

SMC Pneumatics Korea Co., Ltd.

TAIWAN

SMC Pneumatics (Taiwan) Co., Ltd.

THAILAND

SMC Thailand Ltd.

NORTH AMERICA

CANADA

SMC Pneumatics (Canada) Ltd.

MEXICO

SMC Corporation (Mexico) S.A. de C.V.

USA

SMC Corporation of America

SOUTH AMERICA

ARGENTINA

SMC Argentina S.A.

BOLIVIA

SMC Pneumatics Bolivia S.R.L.

BRAZIL

SMC Pneumaticos Do Brazil Ltda.

CHILE

SMC Pneumatics (Chile) S.A.

VENEZUELA

SMC Neumatica Venezuela S.A.

OCEANIA

AUSTRALIA

SMC Pneumatics (Australia) Pty. Ltd.

NEW ZEALAND

SMC Pneumatics (N.Z.) Ltd.

Safety Instructions

Be sure to read "Precautions for Handling Pneumatic Devices" (M-03-E3A) before using.

SMC Corporation

Akihabara UDX 15F,
4-14-1, Sotokanda, Chiyoda-ku, Tokyo 101-0021, JAPAN

Phone: 03-5207-8249 FAX: 03-5298-5362

URL <http://www.smcworld.com>

© 2007 SMC Corporation All Rights Reserved

Specifications are subject to change without prior notice
and any obligation on the part of the manufacturer.

D-DN

1st printing LV printing LV 13500DN Printed in Japan.

This catalog is printed on recycled paper with concern for the global environment.