

Zero Differential Pressure Type Pilot Operated 2 Port Solenoid Valve

New



Air



Water



Oil



Heated water



High temperature oil

Compact Height

4% Smaller* (4 mm)
(VXZ24, C37 (Brass) body)

* Comparison with SMC conventional model

Lightweight Weight

27% Lighter* (150 g)
(VXZ23, Resin body)

- Can be used at 0 m hydraulic head!
- Min. operating pressure differential: 0 MPa (When the valve opens.)

VXZ23

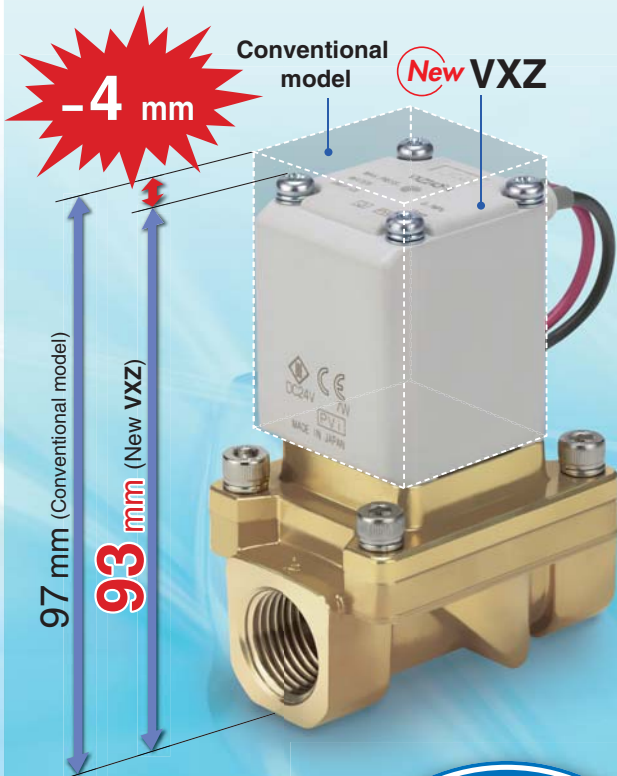

Body material

Aluminium*, Resin* (Built-in One-touch fittings)
* VXZ23

Resin body Aluminium body

Bracket Standard equipment

Applicable tubing O.D.
ø10, ø12
Metric size
ø3/8"
Inch size

Body material

C37 (Brass), Stainless steel (VXZ23 to 26)

C37 (Brass) body Stainless steel body

Enclosure

IP65*

* Electrical entry "Faston" type terminal is IP40.

Valve type

N.C. N.O.

Series VXZ



CAT.EUS70-51A-UK

Zero Differential Pressure Type Pilot Operated 2 Port Solenoid Valve *Series VXZ*



Enclosure
IP65

Flame resistance
UL94V-0 conformed

Piping variations
Thread piping, One-touch fitting

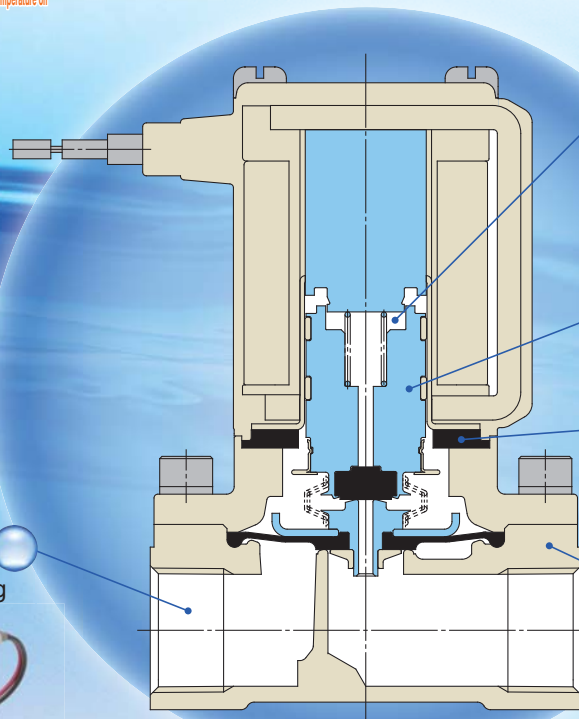

Clearance

By providing a buffer and clearance, we reduced the collision sound of the core when ON (when the valve is open). Because of the clearance, when using highly viscous fluids such as oil, the armature does not get stuck and the responsiveness when OFF (when the valve is closed) is improved.

Improved armature durability

Low-noise construction

Impact noise reduced by the rubber buffer

Body material

Aluminium, Resin **Air** (VXZ2³_A)

C37 (Brass), Stainless steel

Water/Oil/Air/Heated water/High temperature oil

Built-in full-wave rectifier type (AC specification)

- Improved durability**
Service life is extended by a special construction. (compared with current AC specification)
- Reduced buzz noise**
Rectified to DC by a full-wave rectifier, resulting in a buzz noise reduction.
- Improved OFF response**
Specially constructed to improve the OFF response when operated with a higher viscosity fluid such as oil.
- Low-noise construction**
Specially constructed to reduce impact noise during operation.



Variations

<Fluid>

Model	Applicable fluid*				
	Air	Water	Oil	Heated water	High temperature oil
For Air VXZ2□0 P.4	●				
For Water VXZ2□2 P.7	●	●			
For Oil VXZ2□3 P.10	●	●	●		
For Heated water VXZ2□5 P.13	●	●		●	
For High temperature oil VXZ2□6 P.16	●	●	●		●

<Body Size>

Model	Body size	Orifice diameter mmø	Port size	Body material	Fluid
VXZ2 ³ _A	10A	10	1/4, 3/8	Aluminium	
			ø10, ø12, ø3/8"	Resin	
VXZ2 ⁴ _B	15A	15	1/2	C37 (Brass)	
				Stainless steel	
VXZ2 ⁵ _C	20A	20	3/4	C37 (Brass)	
				Stainless steel	
VXZ2 ⁶ _D	25A	25	1	C37 (Brass)	
				Stainless steel	

* For details, refer to pages 35 and 36.

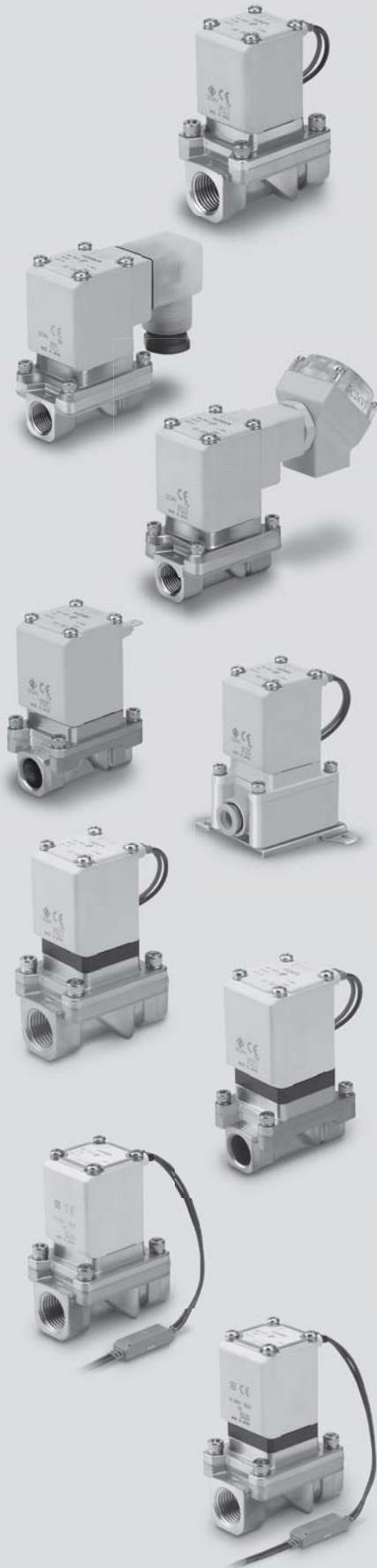

Common Specifications P. 2

Selection Steps P. 3



For Air

Model/Valve Specifications, Fluid and Ambient Temperature, Valve Leakage P. 4, 5

How to Order P. 6



For Water

Model/Valve Specifications, Fluid and Ambient Temperature, Valve Leakage P. 7, 8

How to Order P. 9



For Oil

Model/Valve Specifications, Fluid and Ambient Temperature, Valve Leakage .. P. 10, 11

How to Order P. 12



For Heated Water

Model/Valve Specifications, Fluid and Ambient Temperature, Valve Leakage ... P. 13, 14

How to Order P. 15



For High Temperature Oil

Model/Valve Specifications, Fluid and Ambient Temperature, Valve Leakage ... P. 16, 17

How to Order P. 18

Other Special Options P. 19

Construction P. 20

Dimensions

For Air, Water, Oil

Body material: Resin P. 22

Body material: Aluminium, C37 (Brass), Stainless steel ... P. 24

For Heated Water, High Temperature Oil

Body material: C37 (Brass), Stainless steel P. 26

Replacement Parts P. 27

Glossary of Terms P. 28

Solenoid Valve Flow-rate Characteristics P. 29

Flow-rate Characteristics P. 34

Specific Product Precautions P. 35

Safety Instructions Back cover

Specifications

For Air

For Water

For Oil

For Heated Water

For High Temperature Oil

Options

Construction

Dimensions

Series VXZ

Common Specifications

Standard Specifications

Valve specifications	Valve construction		Zero differential pressure type pilot operated 2 port diaphragm type
	Withstand pressure		2.0 MPa (Resin body type 1.5 MPa)
	Body material		Aluminium, Resin, C37 (Brass), Stainless steel ^{Note 1)}
	Seal material		NBR, FKM, EPDM
	Enclosure		Dust-tight, Water-jet-proof type (equivalent to IP65) ^{Note 2)}
	Environment		Location without corrosive or explosive gases
Coil specifications	Rated voltage	AC	24 VAC, 48 VAC, 100 VAC, 110 VAC, 200 VAC, 220 VAC, 230 VAC, 240 VAC
		DC	12 VDC, 24 VDC
	Allowable voltage fluctuation		±10% of rated voltage
	Allowable leakage voltage	AC (Built-in full-wave rectifier type)	10% or less of rated voltage
		DC	2% or less of rated voltage
Coil insulation type		Class B (for air, water, oil), Class H (for heated water, high temperature oil)	

Note 1) Aluminium body and resin body are available only for the VXZ2³.

Note 2) Electrical entry "Faston" type terminal is IP40.

⚠ Be sure to read "Specific Product Precautions" before handling.

⚠ When pressure differential is less than 0.01 MPa, operation may become unstable. Please contact SMC in case of low flow operation. (Refer to page 21.)

Solenoid Coil Specifications

Normally Closed (N.C.)

DC Specification

Class B

Model	Power consumption [W] ^{Note 1)}	Temperature rise [°C] ^{Note 2)}
VXZ23, 24	7	55
VXZ25, 26	10.5	65

Class H

Model	Power consumption [W] ^{Note 1)}	Temperature rise [°C] ^{Note 2)}
VXZ23, 24	12	100
VXZ25, 26	15	100

Normally Open (N.O.)

DC Specification

Class B

Model	Power consumption [W] ^{Note 1)}	Temperature rise [°C] ^{Note 2)}
VXZ2A, 2B	8.5	70
VXZ2C, 2D	12.5	70

Class H

Model	Power consumption [W] ^{Note 1)}	Temperature rise [°C] ^{Note 2)}
VXZ2A, 2B	12	100
VXZ2C, 2D	15	100

Note 1) Power consumption, Apparent power: The value at ambient temperature of 20°C and when the rated voltage is applied. (Variation: ±10%)

Note 2) The value at ambient temperature of 20°C and when the rated voltage is applied. The value depends on the ambient environment. This is for reference.

Normally Closed (N.C.)

AC Specification (Built-in Full-wave Rectifier Type)

Class B

Model	Apparent power [VA] ^{Note 1) 2)}	Temperature rise [°C] ^{Note 3)}
VXZ23, 24	9.5	70
VXZ25, 26	12	70

Class H

Model	Apparent power [VA] ^{Note 1) 2)}	Temperature rise [°C] ^{Note 3)}
VXZ23, 24	12	100
VXZ25, 26	15	100

Normally Open (N.O.)

AC Specification (Built-in Full-wave Rectifier Type)

Class B

Model	Apparent power [VA] ^{Note 1) 2)}	Temperature rise [°C] ^{Note 3)}
VXZ2A, 2B	10	70
VXZ2C, 2D	14	70

Class H

Model	Apparent power [VA] ^{Note 1) 2)}	Temperature rise [°C] ^{Note 3)}
VXZ2A, 2B	12	100
VXZ2C, 2D	15	100

Note 1) Power consumption, Apparent power: The value at ambient temperature of 20°C and when the rated voltage is applied. (Variation: ±10%)

Note 2) There is no difference in the frequency and the inrush and energized apparent power, since a rectifying circuit is used in the AC (Built-in full-wave rectifier type).

Note 3) The value at ambient temperature of 20°C and when the rated voltage is applied. The value depends on the ambient environment. This is for reference.

Series VXZ Selection Steps

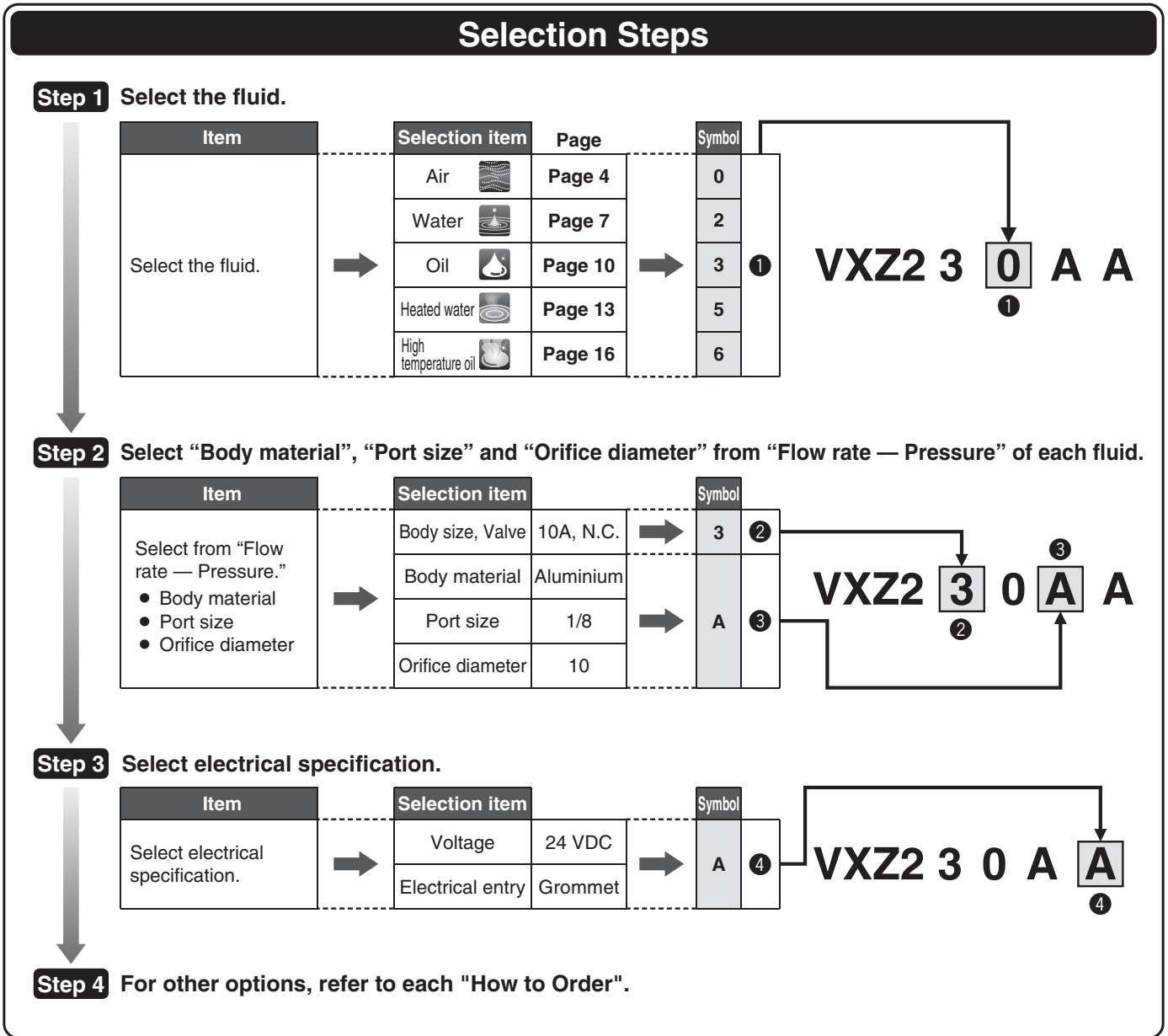

Specifications

For Air

For Water

For Oil

For Heated Water

For High Temperature Oil

Options

Construction

Dimensions

Series VXZ



For Air

* Can be used with low vacuum (up to 133 Pa.abs).

Flow-rate Characteristics

N.C.

Symbol

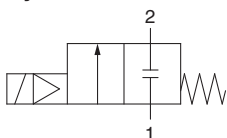

When the valve is closed, flow is blocked from port 1 to port 2. However, if the pressure in port 2 is higher than port 1, the valve will not be able to block the fluid and it will flow from port 2 to port 1.



Normally Closed (N.C.)

Body material	Port size (Nominal diameter)	Orifice diameter [mmø]	Model	Min. operating pressure differential ^{Note 1)} [MPa]	Max. operating pressure differential [MPa]		Flow-rate characteristics				Max. system pressure [MPa]	^{Note 2)} Weight [g]								
					AC	DC	C [dm ³ /(s·bar)]	b	Cv	Effective area [mm ²]										
Resin	ø10	10	VXZ230	0	1.0	0.7	—	—	—	—	1.5	400								
	ø3/8"												0.38	1.7						
	ø12													1.2						
Aluminium	1/4 (8A)	15	VXZ240										1.0	0.7	—	—	—	—	1.5	720
	3/8 (10A)																			
C37 (Brass), Stainless steel	1/2 (15A)	20	VXZ250										1.0	0.7	—	—	—	—	1.5	1100
	3/4 (20A)			2.4																
Stainless steel	1 (25A)	25	VXZ260	1.0	0.7	—	—	—	—	1.5	1300									
	1 (25A)											2.6								
							—		185											

Note 1) The operation of the valve may be unstable due to the capacity of the pressure supply source such as pumps and compressors or the pressure loss by the orifice of piping. Please contact SMC to check if the required valve size can be used in the application. Please contact SMC for the compatibility of the circuit flow and valve size. (Refer to page 21.)

Note 2) Weight of grommet type. Add 10 g for conduit, 30 g for DIN terminal, and 60 g for conduit terminal type respectively.

• Refer to "Glossary of Terms" on page 28 for details on the max. operating pressure differential.

Fluid and Ambient Temperature

Fluid temperature [°C]	Ambient temperature [°C]
-10 ^{Note)} to 60	-20 to 60

Note) Dew point temperature: -10°C or less

Valve Leakage Rate

Internal Leakage

Seal material	Leakage rate (Air) ^{Note 1)}
NBR, FKM	15 cm ³ /min or less (Aluminium body type)
	15 cm ³ /min or less (Resin body type)
	1 cm ³ /min or less (Metal body type)

External Leakage

Seal material	Leakage rate (Air) ^{Note 1)}
NBR, FKM	15 cm ³ /min or less (Aluminium body type)
	15 cm ³ /min or less (Resin body type)
	1 cm ³ /min or less (Metal body type)

Note 1) Leakage is the value at ambient temperature 20°C.

Note 2) When the product is used with low vacuum (to 133 Pa.abs), give caution to the external leakage outlined above.

Flow-rate Characteristics

N.O.

Symbol

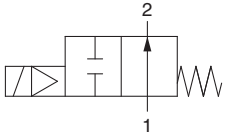

When the valve is closed, flow is blocked from port 1 to port 2. However, if the pressure in port 2 is higher than port 1, the valve will not be able to block the fluid and it will flow from port 2 to port 1.



Normally Open (N.O.)

Body material	Port size (Nominal diameter)	Orifice diameter [mmø]	Model	Min. operating pressure differential ^{Note 1)} [MPa]	Max. operating pressure differential [MPa]		Flow-rate characteristics				Max. system pressure [MPa]	^{Note 2)} Weight [g]
					AC	DC	C [dm ³ /(s·bar)]	b	Cv	Effective area [mm ²]		
Resin	ø10	10	VXZ2A0	0	0.7	0.6	6.2	0.38	1.7	—	1.5	430
	ø3/8"						5.3		1.2			
	ø12						8.0		2.0			
Aluminium	1/4 (8A)	15	VXZ2B0	0	0.7	0.6	8.5	0.44	2.4	—	1.5	630
	3/8 (10A)						9.3		2.6			
C37 (Brass),	1/2 (15A)	15	VXZ2C0	0	0.7	0.6	23.0	0.34	6.0	—	1.5	750
Stainless steel	3/4 (20A)	20	VXZ2D0				36.0		9.4			
	1 (25A)	25	VXZ2D0				—		185			

Note 1) The operation of the valve may be unstable due to the capacity of the pressure supply source such as pumps and compressors or the pressure loss by the orifice of piping. Please contact SMC to check if the required valve size can be used in the application. Please contact SMC for the compatibility of the circuit flow and valve size. (Refer to page 21.)

Note 2) Weight of grommet type. Add 10 g for conduit, 30 g for DIN terminal, and 60 g for conduit terminal type respectively.

• Refer to "Glossary of Terms" on page 28 for details on the max. operating pressure differential.

Fluid and Ambient Temperature

Fluid temperature [°C]	Ambient temperature [°C]
-10 ^{Note)} to 60	-20 to 60

Note) Dew point temperature: -10°C or less

Valve Leakage Rate

Internal Leakage

Seal material	Leakage rate (Air) ^{Note 1)}
NBR, FKM	15 cm ³ /min or less (Aluminium body type)
	15 cm ³ /min or less (Resin body type)
	1 cm ³ /min or less (Metal body type)

External Leakage

Seal material	Leakage rate (Air) ^{Note 1)}
NBR, FKM	15 cm ³ /min or less (Aluminium body type)
	15 cm ³ /min or less (Resin body type)
	1 cm ³ /min or less (Metal body type)

Note 1) Leakage is the value at ambient temperature 20°C.

How to Order (Single Unit)



VXZ2 **3** **0** **A** **A** **A** **□**

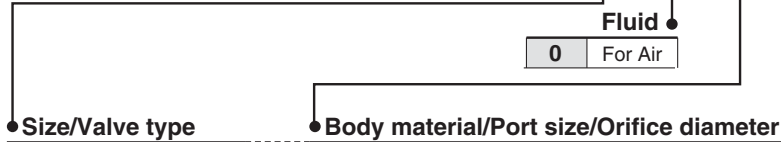

● Size/Valve type			● Body material/Port size/Orifice diameter				
Symbol	Body size	Valve type	Symbol	Body material	Port size	Orifice diameter	
3	10A	N.C.	A	Aluminium	1/4	10	
		N.O.			3/8		
A	10A	N.O.	C	Resin	ø10 One-touch fitting		
					D		ø3/8" One-touch fitting
					E		ø12 One-touch fitting
4	15A	N.C.	F	C37 (Brass)	1/2	15	
		N.O.		G			Stainless steel
B	15A	N.O.	H	C37 (Brass)	3/4	20	
				J			Stainless steel
5	20A	N.C.	K	C37 (Brass)	1	25	
		N.O.		L			Stainless steel
C	20A	N.O.	M	C37 (Brass)	1	25	
				N			Stainless steel

Note 1) VXZ2A0 only possible with other options with one-touch fitting (–, C, H and Z).
 Note 2) If you need a valve for air of C37 (Brass) or stainless steel in the port size of 1/4 or 3/8, use the valve for water.

Voltage/Electrical entry (coil insulation type: Class B)

Symbol	Voltage	Electrical entry	Symbol	Voltage	Electrical entry
A	24 VDC	Grommet	Z1W	24 VAC	Conduit terminal (With surge voltage suppressor)
B	100 VAC	Grommet (With surge voltage suppressor)	Z1N	12 VDC	Conduit (With surge voltage suppressor)
C	110 VAC				
D	200 VAC	DIN terminal (With surge voltage suppressor)	Z1P	48 VAC	Faston terminal
E	230 VAC				
F	24 VDC	Conduit terminal (With surge voltage suppressor)	Z1Q	220 VAC	DIN terminal (With surge voltage suppressor, with light)
G	24 VDC				
H	100 VAC	Conduit (With surge voltage suppressor)	Z1R	240 VAC	Conduit terminal (With surge voltage suppressor, with light)
J	110 VAC				
K	200 VAC	Faston terminal	Z1Y	24 VAC	Conduit terminal (With surge voltage suppressor, with light)
L	230 VAC				
M	24 VDC	Conduit terminal (With surge voltage suppressor)	Z1S	12 VDC	DIN terminal (With surge voltage suppressor, without DIN connector)
N	100 VAC				
P	110 VAC	Conduit (With surge voltage suppressor)	Z1T	12 VDC	DIN terminal (With surge voltage suppressor, without DIN connector)
Q	200 VAC				
R	230 VAC	Faston terminal	Z2A	24 VDC	DIN terminal (With surge voltage suppressor, without DIN connector)
S	24 VDC				
T	100 VAC	Conduit terminal (With surge voltage suppressor)	Z2B	100 VAC	DIN terminal (With surge voltage suppressor, without DIN connector)
U	110 VAC				
V	200 VAC	Conduit (With surge voltage suppressor)	Z2C	110 VAC	DIN terminal (With surge voltage suppressor, without DIN connector)
W	230 VAC				
Y	24 VDC	Faston terminal	Z2D	200 VAC	DIN terminal (With surge voltage suppressor, without DIN connector)
Z1A	48 VAC				
Z1B	220 VAC	Grommet (With surge voltage suppressor)	Z2E	230 VAC	DIN terminal (With surge voltage suppressor, without DIN connector)
Z1C	240 VAC				
Z1U	24 VAC	Grommet (With surge voltage suppressor)	Z2F	48 VAC	DIN terminal (With surge voltage suppressor, without DIN connector)
Z1D	12 VDC				
Z1E	12 VDC	Grommet (With surge voltage suppressor)	Z2G	220 VAC	DIN terminal (With surge voltage suppressor, without DIN connector)
Z1F	48 VAC				
Z1G	220 VAC	DIN terminal (With surge voltage suppressor)	Z2H	240 VAC	DIN terminal (With surge voltage suppressor, without DIN connector)
Z1H	240 VAC				
Z1V	24 VAC	Conduit terminal (With surge voltage suppressor)	Z2V	24 VAC	DIN terminal (With surge voltage suppressor, without DIN connector)
Z1J	12 VDC				
Z1K	48 VAC	Conduit terminal (With surge voltage suppressor)	Z2J	12 VDC	DIN terminal (With surge voltage suppressor, without DIN connector)
Z1L	240 VAC				
Z1M	240 VAC	Conduit terminal (With surge voltage suppressor)	Z2K	24 VDC	DIN terminal (With surge voltage suppressor, without DIN connector)
		Conduit terminal (With surge voltage suppressor)	Z2L	100 VAC	DIN terminal (With surge voltage suppressor, without DIN connector)
		Conduit terminal (With surge voltage suppressor)	Z2M	110 VAC	DIN terminal (With surge voltage suppressor, without DIN connector)
		Conduit terminal (With surge voltage suppressor)	Z2N	200 VAC	DIN terminal (With surge voltage suppressor, without DIN connector)
		Conduit terminal (With surge voltage suppressor)	Z2P	230 VAC	DIN terminal (With surge voltage suppressor, without DIN connector)
		Conduit terminal (With surge voltage suppressor)	Z2Q	48 VAC	DIN terminal (With surge voltage suppressor, without DIN connector)
		Conduit terminal (With surge voltage suppressor)	Z2R	220 VAC	DIN terminal (With surge voltage suppressor, without DIN connector)
		Conduit terminal (With surge voltage suppressor)	Z2S	240 VAC	DIN terminal (With surge voltage suppressor, without DIN connector)
		Conduit terminal (With surge voltage suppressor)	Z2W	24 VAC	DIN terminal (With surge voltage suppressor, without DIN connector)
		Conduit terminal (With surge voltage suppressor)	Z2T	12 VDC	DIN terminal (With surge voltage suppressor, without DIN connector)
		Conduit terminal (With surge voltage suppressor)	Z3A	24 VDC	DIN terminal (With surge voltage suppressor, without DIN connector)
		Conduit terminal (With surge voltage suppressor)	Z3B	100 VAC	DIN terminal (With surge voltage suppressor, without DIN connector)
		Conduit terminal (With surge voltage suppressor)	Z3C	110 VAC	DIN terminal (With surge voltage suppressor, without DIN connector)
		Conduit terminal (With surge voltage suppressor)	Z3D	200 VAC	DIN terminal (With surge voltage suppressor, without DIN connector)
		Conduit terminal (With surge voltage suppressor)	Z3E	230 VAC	DIN terminal (With surge voltage suppressor, without DIN connector)
		Conduit terminal (With surge voltage suppressor)	Z3F	48 VAC	DIN terminal (With surge voltage suppressor, without DIN connector)
		Conduit terminal (With surge voltage suppressor)	Z3G	220 VAC	DIN terminal (With surge voltage suppressor, without DIN connector)
		Conduit terminal (With surge voltage suppressor)	Z3H	240 VAC	DIN terminal (With surge voltage suppressor, without DIN connector)
		Conduit terminal (With surge voltage suppressor)	Z3V	24 VAC	DIN terminal (With surge voltage suppressor, without DIN connector)
		Conduit terminal (With surge voltage suppressor)	Z3J	12 VDC	DIN terminal (With surge voltage suppressor, without DIN connector)

● With bracket

—	No
XB	Yes

Note) Bracket is standardised with the resin body type. No need to add "XB".

* The bracket for aluminium, C37 (Brass) and stainless steel body type is shipped together with the product, but not assembled.

● Other options

Symbol	Seal material ^{Note 1)}	Oil-free	Port thread
—	NBR	—	Rc, With one-touch fitting ^{Note 2)}
A	NBR	—	G
B	NBR	—	NPT
C	FKM	—	Rc, With one-touch fitting ^{Note 2)}
D	NBR	○	G
E	NBR	○	NPT
F	FKM	—	G
G	FKM	—	NPT
H	FKM	○	Rc, With one-touch fitting ^{Note 2)}
K	FKM	○	G
L	FKM	○	NPT
Z	NBR	○	Rc, With one-touch fitting ^{Note 2)}

Note 1) For low concentration ozone resistant, select seal material FKM.

Note 2) One-touch fittings are attached to the resin body type.

For other special options, refer to page 19.

EPDM specification
Special electrical entry direction

Dimensions → Page 22 and after



For Water

* Can be used with air (Up to 133 Pa.abs for vacuum).
Note that the maximum operating pressure differential and flow-rate characteristics should be within the specifications for air.

Flow-rate Characteristics

N.C.

Symbol

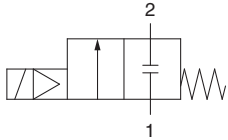

When the valve is closed, flow is blocked from port 1 to port 2. However, if the pressure in port 2 is higher than port 1, the valve will not be able to block the fluid and it will flow from port 2 to port 1.

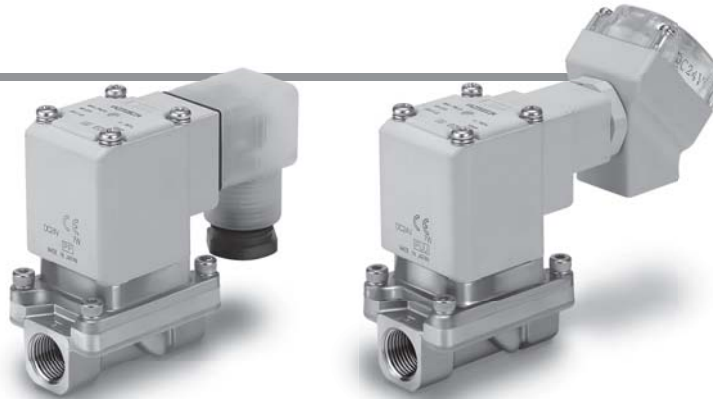

Normally Closed (N.C.)

Body material	Port size (Nominal diameter)	Orifice diameter [mmø]	Model	Min. operating pressure differential ^{Note 1)} [MPa]	Max. operating pressure differential [MPa]		Flow-rate characteristics		Max. system pressure [MPa]	Weight ^{Note 2)} [g]			
					AC	DC	Av x 10 ⁻⁶ m ²	Cv					
C37 (Brass), Stainless steel	1/4 (8A)	10	VXZ232	0	1.0	0.7	46	1.9	1.5	600			
	3/8 (10A)						58	2.4					
	1/2 (15A)	15	VXZ242				130	5.3		720			
	3/4 (20A)						20	VXZ252			220	9.2	1100
	1 (25A)										25	VXZ262	

Note 1) The operation of the valve may be unstable due to the capacity of the pressure supply source such as pumps and compressors or the pressure loss by the orifice of piping. Please contact SMC to check if the required valve size can be used in the application. Please contact SMC for the compatibility of the circuit flow and valve size. (Refer to page 21.)

Note 2) Weight of grommet type. Add 10 g for conduit, 30 g for DIN terminal, and 60 g for conduit terminal type respectively.

• Refer to "Glossary of Terms" on page 28 for details on the max. operating pressure differential.

Fluid and Ambient Temperature

Fluid temperature [°C]	Ambient temperature [°C]
1 to 60	-20 to 60

Note) With no freezing

Valve Leakage Rate

Internal Leakage

Seal material	Leakage rate (Water) ^{Note 1)}
NBR, FKM	0.1 cm ³ /min or less

External Leakage

Seal material	Leakage rate (Water) ^{Note 1)}
NBR, FKM	0.1 cm ³ /min or less

Note 1) Leakage is the value at ambient temperature 20°C.

Specifications

For Air

For Water

For Oil

For Heated Water

For High Temperature Oil

Options

Construction

Dimensions

Series VXZ



Flow-rate Characteristics

N.O.

Symbol

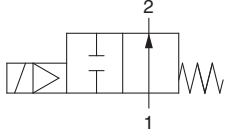

When the valve is closed, flow is blocked from port 1 to port 2. However, if the pressure in port 2 is higher than port 1, the valve will not be able to block the fluid and it will flow from port 2 to port 1.

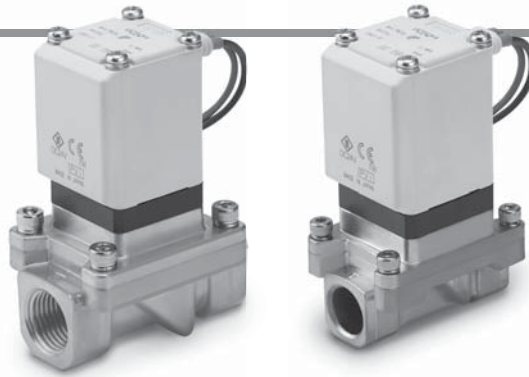

Normally Open (N.O.)

Body material	Port size (Nominal diameter)	Orifice diameter [mmø]	Model	Min. operating pressure differential ^{Note 1} [MPa]	Max. operating pressure differential [MPa]		Flow-rate characteristics		Max. system pressure [MPa]	Weight ^{Note 2} [g]
					AC	DC	Av x 10 ⁻⁶ m ²	Cv		
C37 (Brass), Stainless steel	1/4 (8A)	10	VXZ2A2	0	0.7	0.6	46	1.9	1.5	630
	3/8 (10A)		VXZ2B2				58	2.4		
	1/2 (15A)	VXZ2C2	130				5.3			
	3/4 (20A)	VXZ2C2	220				9.2			
	1 (25A)	VXZ2D2	245				10.2			

Note 1) The operation of the valve may be unstable due to the capacity of the pressure supply source such as pumps and compressors or the pressure loss by the orifice of piping. Please contact SMC to check if the required valve size can be used in the application. Please contact SMC for the compatibility of the circuit flow and valve size. (Refer to page 21.)

Note 2) Weight of grommet type. Add 10 g for conduit, 30 g for DIN terminal, and 60 g for conduit terminal type respectively.

• Refer to "Glossary of Terms" on page 28 for details on the max. operating pressure differential.

Fluid and Ambient Temperature

Fluid temperature [°C]	Ambient temperature [°C]
1 to 60	-20 to 60

Note) With no freezing

Valve Leakage Rate

Internal Leakage

Seal material	Leakage rate (Water) ^{Note 1}
NBR, FKM	0.1 cm ³ /min or less

External Leakage

Seal material	Leakage rate (Water) ^{Note 1}
NBR, FKM	0.1 cm ³ /min or less

Note 1) Leakage is the value at ambient temperature 20°C.



How to Order (Single Unit)

VXZ2 3 2 A A A

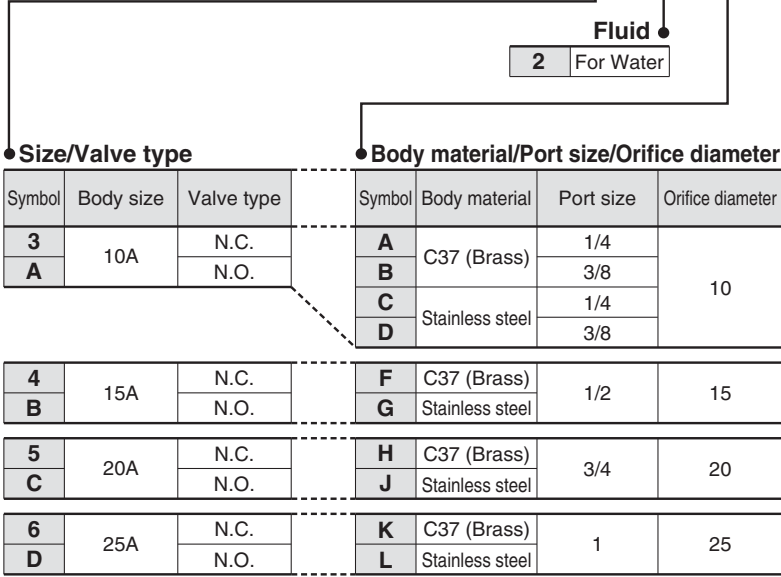

• With bracket

	No
XB	Yes

* The bracket is shipped together with the product, but not assembled.

• Other options

Symbol	Seal material ^{Note}	Oil-free	Port thread
—	NBR	—	Rc
A	NBR	—	G
B			NPT
C	FKM	—	Rc
D	NBR	○	G
E			NPT
F	FKM	—	G
G	FKM	—	NPT
H			Rc
K	FKM	○	G
L			NPT
Z	NBR	○	Rc

Note) For low concentration ozone resistant and deionised water, select seal material FKM.

For other special options, refer to page 19.

EPDM specification
Special electrical entry direction

Voltage/Electrical entry (coil insulation type: Class B)

Symbol	Voltage	Electrical entry	Symbol	Voltage	Electrical entry
A	24 VDC	Grommet	Z1W	24 VAC	Conduit terminal (With surge voltage suppressor)
B	100 VAC	Grommet (With surge voltage suppressor)	Z1N	12 VDC	Conduit (With surge voltage suppressor)
C	110 VAC				
D	200 VAC				
E	230 VAC				
F	24 VDC				
G	24 VDC	DIN terminal (With surge voltage suppressor)	Z1Q	220 VAC	Faston terminal
H	100 VAC				
J	110 VAC				
K	200 VAC				
L	230 VAC	Conduit terminal (With surge voltage suppressor)	Z1S	12 VDC	DIN terminal (With surge voltage suppressor, with light)
M	24 VDC				
N	100 VAC				
P	110 VAC				
Q	200 VAC				
R	230 VAC				
S	24 VDC				
T	100 VAC				
U	110 VAC				
V	200 VAC				
W	230 VAC	Conduit terminal (With surge voltage suppressor, with light)	Z2A	24 VDC	DIN terminal (With surge voltage suppressor, without DIN connector)
Y	24 VDC				
Z1A	48 VAC				
Z1B	220 VAC				
Z1C	240 VAC				
Z1U	24 VAC				
Z1D	12 VDC				
Z1E	12 VDC				
Z1F	48 VAC				
Z1G	220 VAC				
Z1H	240 VAC				
Z1V	24 VAC				
Z1I	12 VDC				
Z1K	48 VAC				
Z1L	220 VAC				
Z1M	240 VAC				
Z2V	24 VAC				
Z2J	12 VDC				
Z2K	24 VDC				
Z2L	100 VAC				
Z2M	110 VAC				
Z2N	200 VAC				
Z2P	230 VAC				
Z2Q	48 VAC				
Z2R	220 VAC				
Z2S	240 VAC				
Z2W	24 VAC				
Z2T	12 VDC				
Z3A	24 VDC				
Z3B	100 VAC				
Z3C	110 VAC				
Z3D	200 VAC				
Z3E	230 VAC				
Z3F	48 VAC				
Z3G	220 VAC				
Z3H	240 VAC				
Z3V	24 VAC				
Z3J	12 VDC				

Dimensions → Page 24 and after

Specifications

For Air

For Water

For Oil

For Heated Water

For High Temperature Oil

Options

Construction

Dimensions

Series VXZ



For Oil

* Can be used with air and water.
Note that the maximum operating pressure differential and flow-rate characteristics should be within the specifications of the fluid used.

⚠ When the fluid is oil.

The kinematic viscosity must not exceed 50 mm²/s. The special construction of the armature adopted in the built-in full-wave rectifier type gives an improvement in OFF response by providing clearance on the absorbed surface when it is switched ON.

Flow-rate Characteristics

N.C.

Symbol

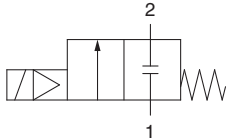

When the valve is closed, flow is blocked from port 1 to port 2. However, if the pressure in port 2 is higher than port 1, the valve will not be able to block the fluid and it will flow from port 2 to port 1.



Normally Closed (N.C.)

Body material	Port size (Nominal diameter)	Orifice diameter [mmø]	Model	Min. operating pressure differential ^{Note 1)} [MPa]	Max. operating pressure differential [MPa]		Flow-rate characteristics		Max. system pressure [MPa]	Weight ^{Note 2)} [g]
					AC	DC	Av x 10 ⁻⁶ m ²	Cv		
C37 (Brass), Stainless steel	1/4 (8A)	10	VXZ233	0	0.7		46	1.9	1.5	600
	3/8 (10A)		VXZ243				58	2.4		720
	1/2 (15A)	15	VXZ253				130	5.3		1100
	3/4 (20A)	20	VXZ253				220	9.2		1300
	1 (25A)	25	VXZ263				245	10.2		

Note 1) The operation of the valve may be unstable due to the capacity of the pressure supply source such as pumps and compressors or the pressure loss by the orifice of piping. Please contact SMC to check if the required valve size can be used in the application. Please contact SMC for the compatibility of the circuit flow and valve size. (Refer to page 21.)

Note 2) Weight of grommet type. Add 10 g for conduit, 30 g for DIN terminal, and 60 g for conduit terminal type respectively.

● Refer to "Glossary of Terms" on page 28 for details on the max. operating pressure differential.

Fluid and Ambient Temperature

Fluid temperature [°C]	Ambient temperature [°C]
-5 ^{Note)} to 60	-20 to 60

Note) Kinematic viscosity: 50 mm²/s or less

Valve Leakage Rate

Internal Leakage

Seal material	Leakage rate (Oil) ^{Note)}
FKM	0.1 cm ³ /min or less

External Leakage

Seal material	Leakage rate (Oil) ^{Note)}
FKM	0.1 cm ³ /min or less

Note) Leakage is the value at ambient temperature 20°C.



Specifications

For Air

For Water

For Oil

For Heated Water

For High Temperature Oil

Options

Construction

Dimensions

Flow-rate Characteristics

N.O.

Symbol

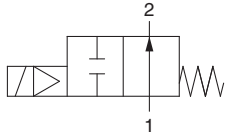

When the valve is closed, flow is blocked from port 1 to port 2. However, if the pressure in port 2 is higher than port 1, the valve will not be able to block the fluid and it will flow from port 2 to port 1.



Normally Open (N.O.)

Body material	Port size (Nominal diameter)	Orifice diameter [mmø]	Model	Min. operating pressure differential ^{Note 1)} [MPa]	Max. operating pressure differential [MPa]		Flow-rate characteristics		Max. system pressure [MPa]	Weight ^{Note 2)} [g]
					AC	DC	Av x 10 ⁻⁶ m ²	Cv		
C37 (Brass), Stainless steel	1/4 (8A)	10	VXZ2A3	0	0.7	0.6	46	1.9	1.5	630
	3/8 (10A)		VXZ2B3				58	2.4		750
	1/2 (15A)	VXZ2C3	130				5.3	1150		
	3/4 (20A)	VXZ2C3	220				9.2	1350		
	1 (25A)	VXZ2D3	245				10.2			

Note 1) The operation of the valve may be unstable due to the capacity of the pressure supply source such as pumps and compressors or the pressure loss by the orifice of piping. Please contact SMC to check if the required valve size can be used in the application. Please contact SMC for the compatibility of the circuit flow and valve size. (Refer to page 21.)

Note 2) Weight of grommet type. Add 10 g for conduit, 30 g for DIN terminal, and 60 g for conduit terminal type respectively.

● Refer to "Glossary of Terms" on page 28 for details on the max. operating pressure differential.

Fluid and Ambient Temperature

Fluid temperature [°C]	Ambient temperature [°C]
-5 ^{Note)} to 60	-20 to 60

Note) Kinematic viscosity: 50 mm²/s or less

Valve Leakage Rate

Internal Leakage

Seal material	Leakage rate (Oil) ^{Note)}
FKM	0.1 cm ³ /min or less

External Leakage

Seal material	Leakage rate (Oil) ^{Note)}
FKM	0.1 cm ³ /min or less

Note) Leakage is the value at ambient temperature 20°C.

Series VXZ



How to Order (Single Unit)

VXZ2 **3** **3** **A** **A** **A**

Common Specifications	
Seal material	FKM

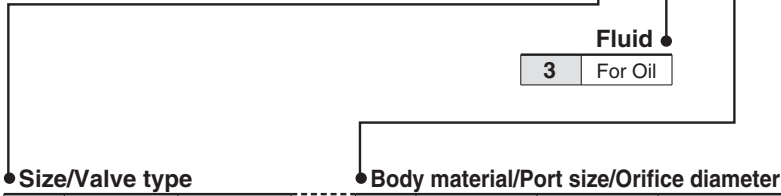

Size/Valve type			Body material/Port size/Orifice diameter							
Symbol	Body size	Valve type	Symbol	Body material	Port size	Orifice diameter				
3	10A	N.C.	A	C37 (Brass)	1/4	10				
A		N.O.								
4	15A	N.C.					F	C37 (Brass)	1/2	15
B		N.O.								
5	20A	N.C.	H	C37 (Brass)	3/4	20				
C		N.O.								
6	25A	N.C.	K	C37 (Brass)	1	25				
D		N.O.								

• With bracket

—	No
XB	Yes

* The bracket is shipped together with the product, but not assembled.

• Other options

Symbol	Oil-free	Port thread
—	—	Rc
A	—	G
B	—	NPT
D	○	G
E	○	NPT
Z	○	Rc

For other special options, refer to page 19.

Special electrical entry direction

Voltage/Electrical entry (coil insulation type: Class B)

Symbol	Voltage	Electrical entry	Symbol	Voltage	Electrical entry	
A	24 VDC	Grommet	Z1W	24 VAC	Conduit terminal (With surge voltage suppressor)	
B	100 VAC	Grommet (With surge voltage suppressor)	Z1N	12 VDC		
C	110 VAC		Z1P	48 VAC	Conduit (With surge voltage suppressor)	
D	200 VAC		Z1Q	220 VAC		
E	230 VAC		Z1R	240 VAC		
F	24 VDC		Z1Y	24 VAC		
G	24 VDC	Z1S	12 VDC			
H	100 VAC	DIN terminal (With surge voltage suppressor)	Z1T	12 VDC		Faston terminal
J	110 VAC		Z2A	24 VDC	DIN terminal (With surge voltage suppressor, with light)	
K	200 VAC		Z2B	100 VAC		
L	230 VAC		Z2C	110 VAC		
M	24 VDC	Z2D	200 VAC			
N	100 VAC	Conduit terminal (With surge voltage suppressor)	Z2E	230 VAC		
P	110 VAC		Z2F	48 VAC		
Q	200 VAC		Z2G	220 VAC		
R	230 VAC		Z2H	240 VAC		
S	24 VDC	Conduit (With surge voltage suppressor)	Z2V	24 VAC		Conduit terminal (With surge voltage suppressor, with light)
T	100 VAC		Z2J	12 VDC		
U	110 VAC		Z2K	24 VDC		
V	200 VAC		Z2L	100 VAC		
W	230 VAC	Faston terminal	Z2M	110 VAC		
Y	24 VDC		Z2N	200 VAC		
Z1A	48 VAC		Grommet (With surge voltage suppressor)	Z2P	230 VAC	
Z1B	220 VAC			Z2Q	48 VAC	
Z1C	240 VAC	Z2R		220 VAC		
Z1U	24 VAC	Z2S		240 VAC		
Z1D	12 VDC	Grommet	Z2W	24 VAC	DIN terminal (With surge voltage suppressor, without DIN connector)	
Z1E	12 VDC	Grommet (With surge voltage suppressor)	Z2T	12 VDC		
Z1F	48 VAC	DIN terminal (With surge voltage suppressor)	Z3A	24 VDC		
Z1G	220 VAC		Z3B	100 VAC		
Z1H	240 VAC		Z3C	110 VAC		
Z1V	24 VAC		Z3D	200 VAC		
Z1J	12 VDC		Z3E	230 VAC		
Z1K	48 VAC	Conduit terminal (With surge voltage suppressor)	Z3F	48 VAC		
Z1L	220 VAC		Z3G	220 VAC		
Z1M	240 VAC		Z3H	240 VAC		
				Z3V	24 VAC	
			Z3J	12 VDC		

Dimensions → Page 24 and after



For Heated Water

* Can be used with air (up to 99°C) and water.
Note that the maximum operating pressure differential and flow-rate characteristics should be within the specifications of the fluid used.

Flow-rate Characteristics

N.C.

Symbol

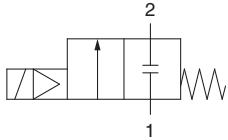

When the valve is closed, flow is blocked from port 1 to port 2. However, if the pressure in port 2 is higher than port 1, the valve will not be able to block the fluid and it will flow from port 2 to port 1.



Normally Closed (N.C.)

Body material	Port size (Nominal diameter)	Orifice diameter [mmø]	Model	Min. operating pressure differential ^{Note 1)} [MPa]	Max. operating pressure differential [MPa]		Flow-rate characteristics		Max. system pressure [MPa]	Weight ^{Note 2)} [g]
					AC	DC	Av x 10 ⁻⁶ m ²	Cv		
C37 (Brass), Stainless steel	1/4 (8A)	10	VXZ235	0	1.0	0.7	46	1.9	1.5	600
	3/8 (10A)						58	2.4		720
	1/2 (15A)	15	VXZ245				130	5.3		1100
	3/4 (20A)						20	VXZ255		220
	1 (25A)	25	VXZ265							245

Note 1) The operation of the valve may be unstable due to the capacity of the pressure supply source such as pumps and compressors or the pressure loss by the orifice of piping. Please contact SMC to check if the required valve size can be used in the application. Please contact SMC for the compatibility of the circuit flow and valve size. (Refer to page 21.)

Note 2) Weight of grommet type. Add 10 g for conduit, 30 g for DIN terminal, and 60 g for conduit terminal type respectively.

• Refer to "Glossary of Terms" on page 28 for details on the max. operating pressure differential.

Fluid and Ambient Temperature

Fluid temperature [°C]	Ambient temperature [°C]
1 to 99	-20 to 60

Note) With no freezing

Valve Leakage Rate

Internal Leakage

Seal material	Leakage rate (Water) ^{Note)}
EPDM	0.1 cm ³ /min or less

External Leakage

Seal material	Leakage rate (Water) ^{Note)}
EPDM	0.1 cm ³ /min or less

Note) Leakage is the value at ambient temperature 20°C.

Specifications

For Air

For Water

For Oil

For Heated Water

For High Temperature Oil

Options

Construction

Dimensions

Series VXZ



For Heated Water

Flow-rate Characteristics

N.O.

Symbol

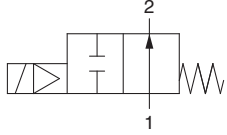

When the valve is closed, flow is blocked from port 1 to port 2. However, if the pressure in port 2 is higher than port 1, the valve will not be able to block the fluid and it will flow from port 2 to port 1.



Normally Open (N.O.)

Body material	Port size (Nominal diameter)	Orifice diameter [mmø]	Model	Min. operating pressure differential ^{Note 1} [MPa]	Max. operating pressure differential [MPa]		Flow-rate characteristics		Max. system pressure [MPa]	Weight ^{Note 2} [g]
					AC	DC	Av x 10 ⁻⁶ m ²	Cv		
C37 (Brass), Stainless steel	1/4 (8A)	10	VXZ2A5	0	0.7	0.6	46	1.9	1.5	630
	3/8 (10A)		58				2.4			
	1/2 (15A)	15	VXZ2B5				130	5.3		
	3/4 (20A)	20	VXZ2C5				220	9.2		
	1 (25A)	25	VXZ2D5				245	10.2		

Note 1) The operation of the valve may be unstable due to the capacity of the pressure supply source such as pumps and compressors or the pressure loss by the orifice of piping. Please contact SMC to check if the required valve size can be used in the application. Please contact SMC for the compatibility of the circuit flow and valve size. (Refer to page 21.)

Note 2) Weight of grommet type. Add 10 g for conduit, 30 g for DIN terminal, and 60 g for conduit terminal type respectively.

● Refer to "Glossary of Terms" on page 28 for details on the max. operating pressure differential.

Fluid and Ambient Temperature

Fluid temperature [°C]	Ambient temperature [°C]
1 to 99	-20 to 60

Note) With no freezing

Valve Leakage Rate

Internal Leakage

Seal material	Leakage rate (Water) ^{Note)}
EPDM	0.1 cm ³ /min or less

External Leakage

Seal material	Leakage rate (Water) ^{Note)}
EPDM	0.1 cm ³ /min or less

Note) Leakage is the value at ambient temperature 20°C.



How to Order (Single Unit)

VXZ2 **3** **5** **A** **A** **A**

Common Specifications

Seal material	EPDM
---------------	------

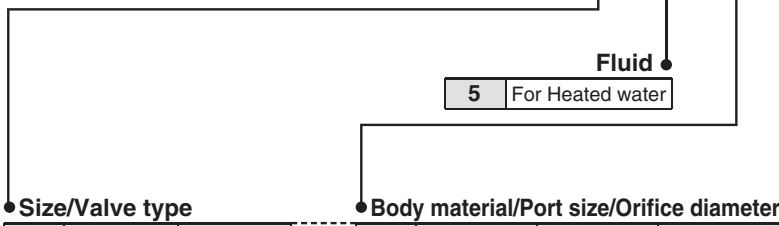

Size/Valve type			Body material/Port size/Orifice diameter				
Symbol	Body size	Valve type	Symbol	Body material	Port size	Orifice diameter	
3	10A	N.C.	A	C37 (Brass)	1/4	10	
		N.O.			3/8		
4	15A	N.C.			C		1/4
		N.O.			D		3/8
5	20A	N.C.	F	1/2	15		
		N.O.	G	3/4			
6	25A	N.C.	H	1	25		
		N.O.	J	25			

With bracket

—	No
XB	Yes

* The bracket is shipped together with the product, but not assembled.

Other options

Symbol	Oil-free	Port thread
—	—	Rc
A	—	G
B	—	NPT
D	○	G
E	○	NPT
Z	○	Rc

For other special options, refer to page 19.

Special electrical entry direction

Voltage/Electrical entry (coil insulation type: Class H)

Symbol	Voltage	Electrical entry ^{Note 3)}	Symbol	Voltage	Electrical entry ^{Note 3)}
A	24 VDC	Grommet	Z1P	48 VAC	Conduit (With surge voltage suppressor)
B	100 VAC	Grommet (With surge voltage suppressor)	Z1Q	220 VAC	
C	110 VAC		Z1R	240 VAC	
D	200 VAC		Z1Y	24 VAC	
E	230 VAC		Z2A	24 VDC	DIN terminal ^{Note 1) 2)} (With surge voltage suppressor, with light)
G	24 VDC	Z2B	100 VAC		
H	100 VAC	Z2C	110 VAC		
J	110 VAC	Z2D	200 VAC		
K	200 VAC	Z2E	230 VAC		
L	230 VAC	Z2F	48 VAC		
N	100 VAC	Z2G	220 VAC		
P	110 VAC	Z2H	240 VAC		
Q	200 VAC	Z2V	24 VAC		
R	230 VAC	Z2K	24 VDC	Conduit terminal (With surge voltage suppressor, with light)	
T	100 VAC	Z2L	100 VAC		
U	110 VAC	Z2M	110 VAC		
V	200 VAC	Z2N	200 VAC		
W	230 VAC	Z2P	230 VAC		
Z1A	48 VAC	Z2Q	48 VAC		
Z1B	220 VAC	Z2R	220 VAC		
Z1C	240 VAC	Z2S	240 VAC		
Z1U	24 VAC	Z2W	24 VAC		
Z1F	48 VAC	DIN terminal ^{Note 1) 2)} (With surge voltage suppressor)			
Z1G	220 VAC				
Z1H	240 VAC				
Z1V	24 VAC				
Z1K	48 VAC	Conduit terminal (With surge voltage suppressor)			
Z1L	220 VAC				
Z1M	240 VAC				
Z1W	24 VAC				

Note 1) AC voltage coil for "H" of DIN terminal type does not have full-wave rectifier.

Full-wave rectifier is built on the DIN connector side. Please refer to page 27 to order it as an accessory.

Note 2) DIN connector insulation class is Class "B".

Note 3) Faston terminal is not available.

Dimensions → Page 26 and after

Specifications

For Air

For Water

For Oil

For Heated Water

For High Temperature Oil

Options

Construction

Dimensions

Series VXZ



For High Temperature Oil

* Can be used with air (up to 99°C), water (up to 99°C) and oil. Note that the maximum operating pressure differential and flow-rate characteristics should be within the specifications of the fluid used.

⚠ When the fluid is oil.

The kinematic viscosity must not exceed 50 mm²/s. The special construction of the armature adopted in the built-in full-wave rectifier type gives an improvement in OFF response by providing clearance on the absorbed surface when it is switched ON.

Flow-rate Characteristics

N.C.

Symbol

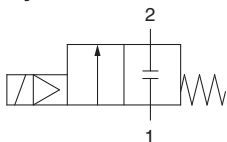

When the valve is closed, flow is blocked from port 1 to port 2. However, if the pressure in port 2 is higher than port 1, the valve will not be able to block the fluid and it will flow from port 2 to port 1.



Normally Closed (N.C.)

Body material	Port size (Nominal diameter)	Orifice diameter [mmø]	Model	Min. operating pressure differential ^{Note 1)} [MPa]	Max. operating pressure differential [MPa]		Flow-rate characteristics		Max. system pressure [MPa]	Weight ^{Note 2)} [g]
					AC	DC	Av x 10 ⁻⁶ m ²	Cv		
C37 (Brass), Stainless steel	1/4 (8A)	10	VXZ236	0	0.7		46	1.9	1.5	600
	3/8 (10A)		VXZ246				58	2.4		720
	1/2 (15A)	VXZ256	130				5.3	1100		
	3/4 (20A)	VXZ256	220				9.2	1300		
	1 (25A)	VXZ266	245				10.2			

Note 1) The operation of the valve may be unstable due to the capacity of the pressure supply source such as pumps and compressors or the pressure loss by the orifice of piping. Please contact SMC to check if the required valve size can be used in the application. Please contact SMC for the compatibility of the circuit flow and valve size. (Refer to page 21.)

Note 2) Weight of grommet type. Add 10 g for conduit, 30 g for DIN terminal, and 60 g for conduit terminal type respectively.

• Refer to "Glossary of Terms" on page 28 for details on the max. operating pressure differential.

Fluid and Ambient Temperature

Fluid temperature [°C]	Ambient temperature [°C]
-5 ^{Note)} to 100	-20 to 60

Note) Kinematic viscosity: 50 mm²/s or less

Valve Leakage Rate

Internal Leakage

Seal material	Leakage rate (Oil) ^{Note)}
FKM	0.1 cm ³ /min or less

External Leakage

Seal material	Leakage rate (Oil) ^{Note)}
FKM	0.1 cm ³ /min or less

Note) Leakage is the value at ambient temperature 20°C.



Flow-rate Characteristics

N.O.

Symbol

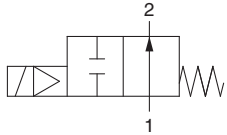

When the valve is closed, flow is blocked from port 1 to port 2. However, if the pressure in port 2 is higher than port 1, the valve will not be able to block the fluid and it will flow from port 2 to port 1.



Normally Open (N.O.)

Body material	Port size (Nominal diameter)	Orifice diameter [mmø]	Model	Min. operating pressure differential ^{Note 1)} [MPa]	Max. operating pressure differential [MPa]		Flow-rate characteristics		Max. system pressure [MPa]	Weight ^{Note 2)} [g]
					AC	DC	Av x 10 ⁻⁶ m ²	Cv		
C37 (Brass), Stainless steel	1/4 (8A)	10	VXZ2A6	0	0.7	0.6	46	1.9	1.5	630
	3/8 (10A)						58	2.4		
	1/2 (15A)	15	VXZ2B6				130	5.3		
	3/4 (20A)	20	VXZ2C6				220	9.2		
	1 (25A)	25	VXZ2D6				245	10.2		

Note 1) The operation of the valve may be unstable due to the capacity of the pressure supply source such as pumps and compressors or the pressure loss by the orifice of piping. Please contact SMC to check if the required valve size can be used in the application. Please contact SMC for the compatibility of the circuit flow and valve size. (Refer to page 21.)

Note 2) Weight of grommet type. Add 10 g for conduit, 30 g for DIN terminal, and 60 g for conduit terminal type respectively.

• Refer to "Glossary of Terms" on page 28 for details on the max. operating pressure differential.

Fluid and Ambient Temperature

Fluid temperature [°C]	Ambient temperature [°C]
-5 ^{Note)} to 100	-20 to 60

Note) Kinematic viscosity: 50 mm²/s or less

Valve Leakage Rate

Internal Leakage

Seal material	Leakage rate (Oil) ^{Note)}
FKM	0.1 cm ³ /min or less

External Leakage

Seal material	Leakage rate (Oil) ^{Note)}
FKM	0.1 cm ³ /min or less

Note) Leakage is the value at ambient temperature 20°C.

Series VXZ

 For High Temperature Oil



How to Order (Single Unit)

VXZ2 **3** **6** **A** **A** **A**

Common Specifications	
Seal material	FKM

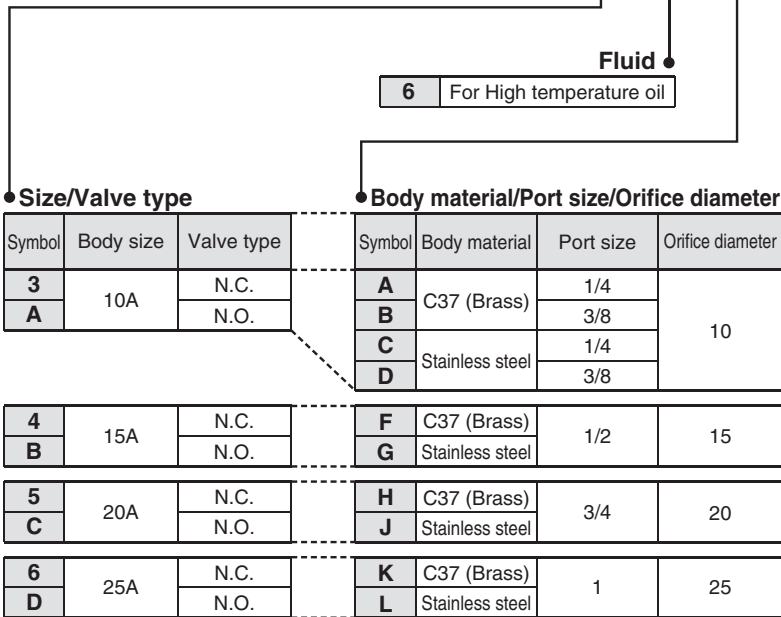

Size/Valve type

Symbol	Body size	Valve type
3	10A	N.C.
A		N.O.

Body material/Port size/Orifice diameter

Symbol	Body material	Port size	Orifice diameter
A	C37 (Brass)	1/4	10
B		3/8	
C	Stainless steel	1/4	
D		3/8	

Symbol	Body size	Valve type	Symbol	Body material	Port size	Orifice diameter
4	15A	N.C.	F	C37 (Brass)	1/2	15
B		N.O.	G	Stainless steel		

Symbol	Body size	Valve type	Symbol	Body material	Port size	Orifice diameter
5	20A	N.C.	H	C37 (Brass)	3/4	20
C		N.O.	J	Stainless steel		

Symbol	Body size	Valve type	Symbol	Body material	Port size	Orifice diameter
6	25A	N.C.	K	C37 (Brass)	1	25
D		N.O.	L	Stainless steel		

With bracket

—	No
XB	Yes

* The bracket is shipped together with the product, but not assembled.

Other options

Symbol	Oil-free	Port thread
—	—	Rc
A	—	G
B		NPT
D	○	G
E		NPT
Z	○	Rc

For other special options, refer to page 19.

Special electrical entry direction

Voltage/Electrical entry (coil insulation type: Class H)

Symbol	Voltage	Electrical entry ^{Note 3)}	Symbol	Voltage	Electrical entry ^{Note 3)}	
A	24 VDC	Grommet	Z1P	48 VAC	Conduit (With surge voltage suppressor)	
B	100 VAC	Grommet (With surge voltage suppressor)	Z1Q	220 VAC		
C	110 VAC		Z1R	240 VAC		
D	200 VAC		Z1Y	24 VAC		
E	230 VAC		DIN terminal ^{Note 1) 2)} (With surge voltage suppressor)	Z2A	24 VDC	DIN terminal ^{Note 1) 2)} (With surge voltage suppressor, with light)
G	24 VDC	Z2B		100 VAC		
H	100 VAC	Z2C		110 VAC		
J	110 VAC	Z2D		200 VAC		
K	200 VAC	Z2E		230 VAC		
L	230 VAC	Z2F		48 VAC		
N	100 VAC	Conduit terminal (With surge voltage suppressor)		Z2G	220 VAC	
P	110 VAC			Z2H	240 VAC	
Q	200 VAC			Z2V	24 VAC	
R	230 VAC			Z2K	24 VDC	
T	100 VAC		Conduit terminal (With surge voltage suppressor, with light)	Z2L	100 VAC	
U	110 VAC			Z2M	110 VAC	
V	200 VAC	Z2N		200 VAC		
W	230 VAC	Z2P		230 VAC		
Z1A	48 VAC	Grommet (With surge voltage suppressor)		Z2Q	48 VAC	
Z1B	220 VAC			Z2R	220 VAC	
Z1C	240 VAC			Z2S	240 VAC	
Z1U	24 VAC			Z2W	24 VAC	
Z1F	48 VAC	DIN terminal ^{Note 1) 2)} (With surge voltage suppressor)				
Z1G	220 VAC					
Z1H	240 VAC					
Z1V	24 VAC					
Z1K	48 VAC	Conduit terminal (With surge voltage suppressor)				
Z1L	220 VAC					
Z1M	240 VAC					
Z1W	24 VAC					

Note 1) AC voltage coil for "H" of DIN terminal type does not have full-wave rectifier.

Full-wave rectifier is built on the DIN connector side. Please refer to page 27 to order it as an accessory.

Note 2) DIN connector insulation class is Class "B".

Note 3) Faston terminal is not available.

Dimensions → Page 26 and after

EPDM specification

VXZ X332

Enter standard product number.

EPDM specification

Coil mounting direction

Symbol	Specifications	
	Electrical entry direction	Bracket
—	IN side (Standard)	None
A	90°	
B	180°	
C	270°	
D	IN side (Standard)	With bracket *1
E	90°	
F	180°	
G	270°	

*1 Resin body is not available.

*2 Available for air and water.

*3 "Other options", which can be combined, are —, A, B, D, E, Z.

Special electrical entry direction

VXZ2 XC A

Enter standard product number.

Symbol	Bracket
XC	Without bracket
XB*	With bracket

Symbol	Rotation angle
A	
B	
C	

*1 Bracket is attached as standard with the resin body type (VXZ2³_{A0}^C_D□), so it is not necessary to add XB to the part number.

*2 Bracket is packed in the same container as the main body.

Specifications

For Air

For Water

For Oil

For Heated Water

For High Temperature Oil

Options

Construction

Dimensions

* Enter symbols in the order below when ordering a combination of electrical option, other option, etc.

Example) VXZ2

Electrical option

Other option

Special electrical entry direction

With bracket

Series VXZ Construction

Normally Closed (N.C.)

Body material: Aluminium, C37 (Brass), Stainless steel

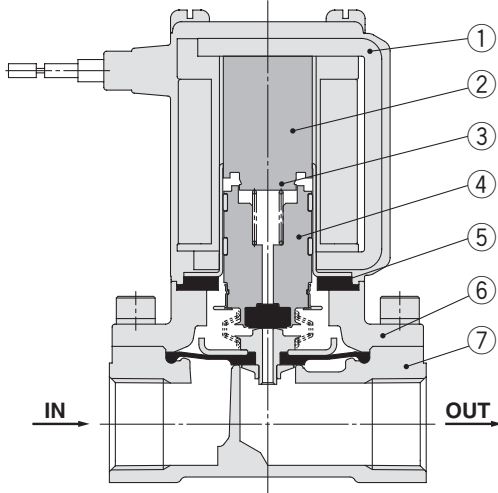

Component Parts

No.	Description	Material
1	Solenoid coil	Cu + Fe + Resin
2	Tube assembly	Stainless steel
3	Return spring	Stainless steel
4	Armature/Diaphragm assembly	Stainless steel, NBR, FKM, EPDM
5	Stopper	NBR, FKM, EPDM
6	Bonnet	Aluminium, C37 (Brass), Stainless steel
7	Body	Aluminium, C37 (Brass), Stainless steel

Body material: Resin

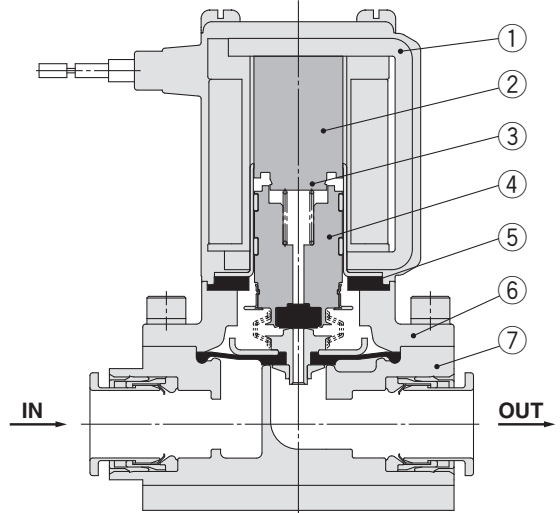

Component Parts

No.	Description	Material
1	Solenoid coil	Cu + Fe + Resin
2	Tube assembly	Stainless steel
3	Return spring	Stainless steel
4	Armature/Diaphragm assembly	Stainless steel, NBR, FKM
5	Stopper	NBR, FKM
6	Bonnet	Aluminium
7	Body	Resin (PBT)

Normally Open (N.O.)

Body material: Aluminium, C37 (Brass), Stainless steel

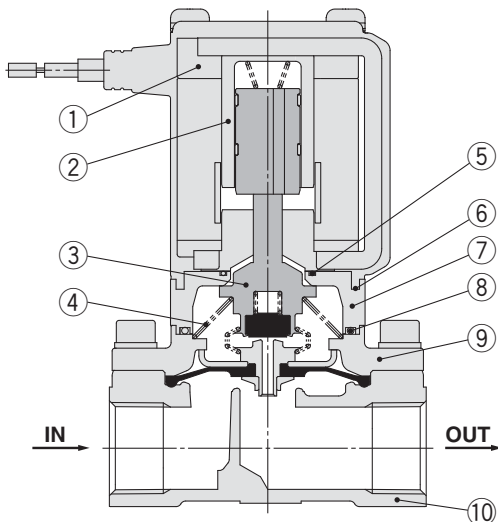

Component Parts

No.	Description	Material
1	Solenoid coil	Cu + Fe + Resin
2	Sleeve assembly	Stainless steel, Resin (PPS)
3	Push rod/Diaphragm assembly	Stainless steel, NBR, FKM, EPDM
4	Spring	Stainless steel
5	O-ring A	NBR, FKM, EPDM
6	O-ring B	NBR, FKM, EPDM
7	Adapter	Resin (PPS)
8	O-ring C	NBR, FKM, EPDM
9	Bonnet	Aluminium, C37 (Brass), Stainless steel
10	Body	Aluminium, C37 (Brass), Stainless steel

Body material: Resin

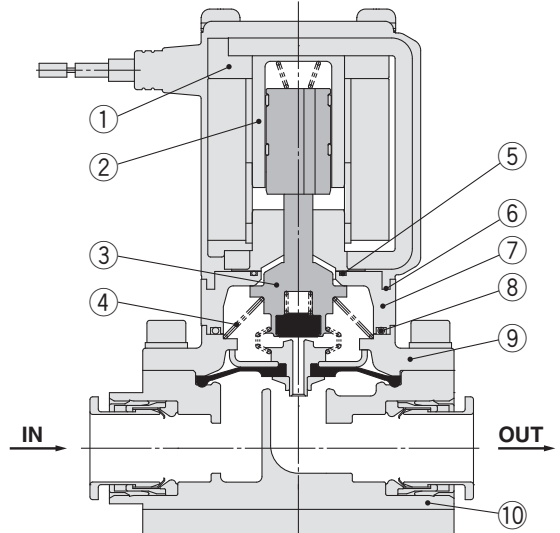

Component Parts

No.	Description	Material
1	Solenoid coil	Cu + Fe + Resin
2	Sleeve assembly	Stainless steel, Resin (PPS)
3	Push rod/Diaphragm assembly	Stainless steel, NBR, FKM
4	Spring	Stainless steel
5	O-ring A	NBR, FKM
6	O-ring B	NBR, FKM
7	Adapter	Resin (PPS)
8	O-ring C	NBR, FKM
9	Bonnet	Aluminium
10	Body	Resin (PBT)

Working Principle

De-energized

The fluid enters from the IN goes through the supply orifice to fill the pressure action chamber. Main valve is closed by the pressure in the pressure action chamber and the reaction force of the return spring.

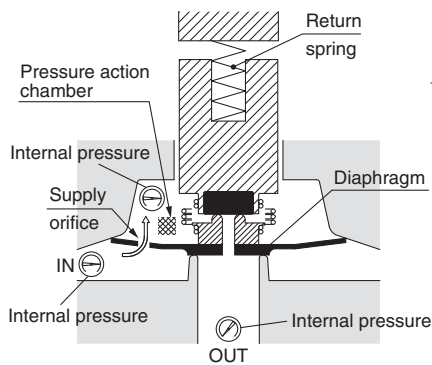

Right after energized (Pilot valve open)

When the coil is energized, the armature is attracted causing the pilot orifice to opening. The fluid filling the pressure action chamber flows to the OUT side through the pilot orifice.

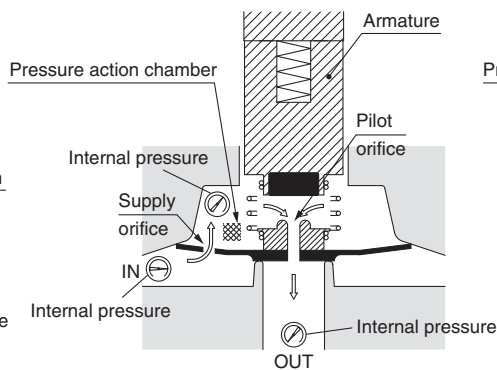

Energized (Main valve side)

The pressure in the pressure action chamber decreases by discharging fluid through the pilot orifice. Because the force which pushes down the valve is reduced by the discharge of the fluid, the force that pushes up the main valve overcomes the push down force and opens the main valve. The main valve opens by the lift spring reaction force even if pressure on the IN side is 0 MPa or very low pressure.

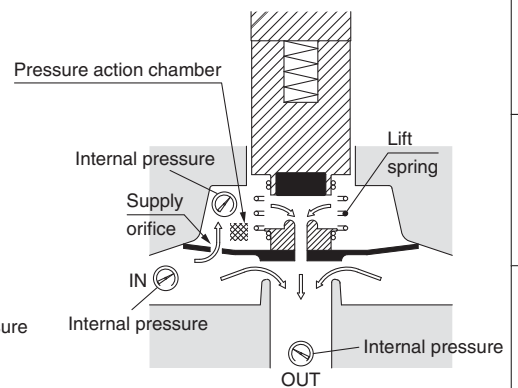

Warning

Unstable flow may occur with the product under the following conditions: • low flow from the pump or compressor, etc. • use of several elbows or tees in the circuit, or • thin nozzles installed at the end of the piping etc. This can cause valve opening/closing failure, or oscillation, and cause a valve malfunction. If products are used with vacuum, then the vacuum level can be unstable due to these conditions. Please contact SMC to check if the valve can be used in the application by providing the relevant fluid circuit.

Specifications

For Air

For Water

For Oil

For Heated Water

For High Temperature Oil

Options

Construction

Dimensions

Series VXZ



For Air

Dimensions/Body Material: Resin (One-touch Fitting Type)

Grommet

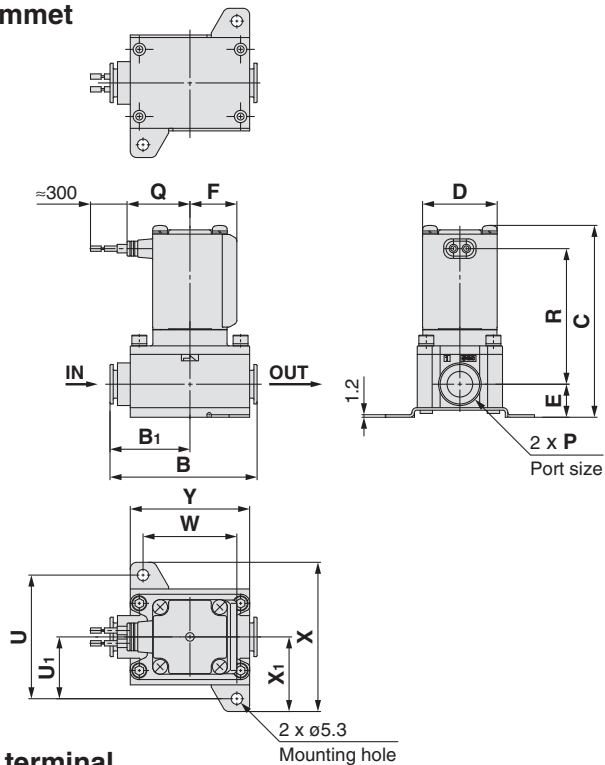

Grommet (with surge voltage suppressor)

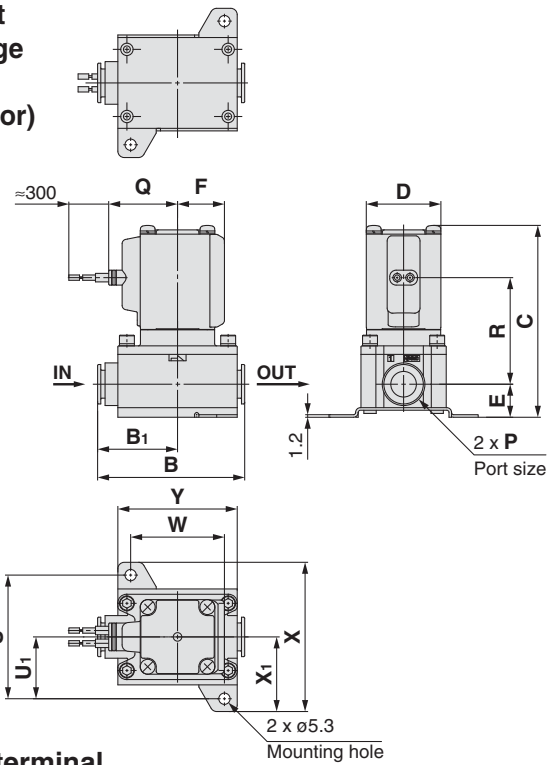

DIN terminal

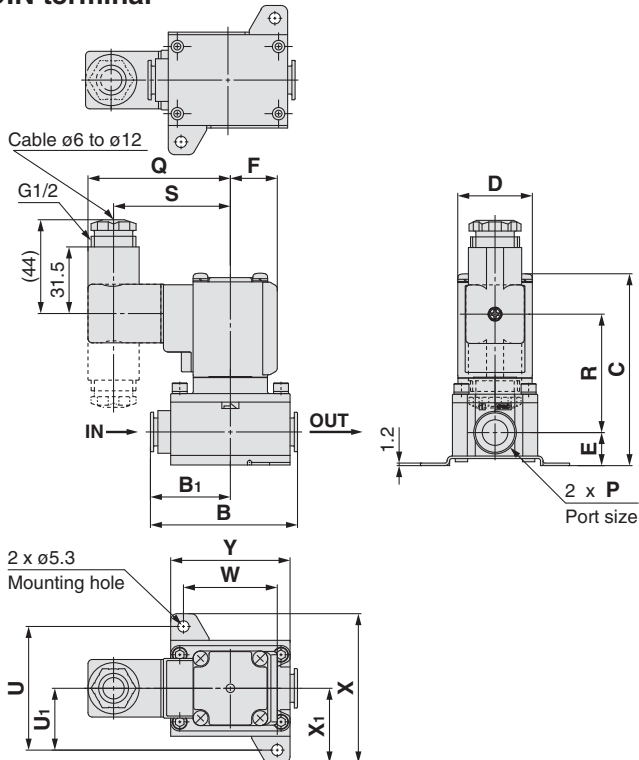

Conduit terminal

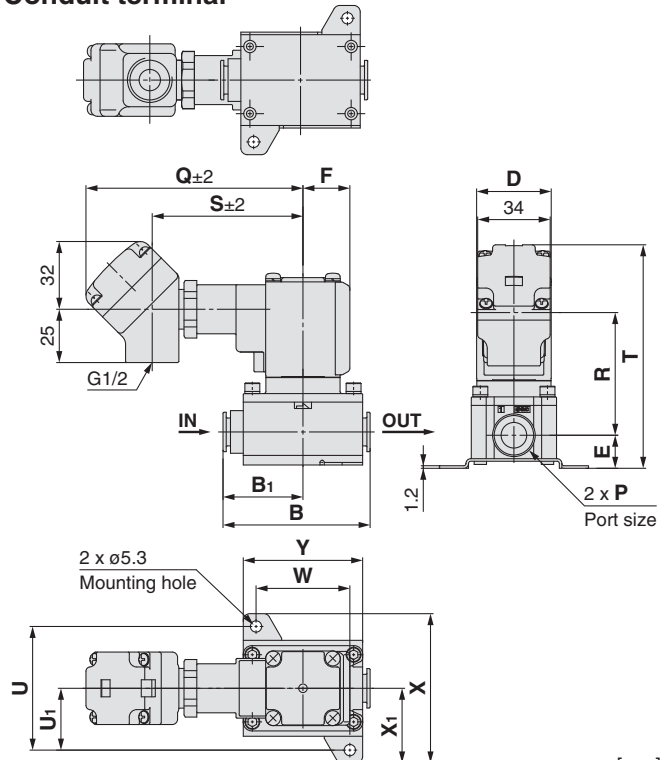

[mm]

Model	One-touch fitting P	B	B ₁	C	D	E	F	Bracket mounting					
								U	U ₁	W	X	X ₁	Y
VXZ2 ³ _A	ø10, ø3/8", ø12	69	37.5	90 (96.5)	35	15.5	22	54	27	44	65	32.5	56

For information on handling One-touch fittings and appropriate tubing, refer to KQ2 series One-touch fittings in SMC website, <http://www.smc.eu>

Model	One-touch fitting P	Electrical entry										
		Grommet		Grommet (with surge voltage suppressor)		DIN terminal		Conduit terminal				
		Q	R	Q	R	Q	R	S	Q	R	S	T
VXZ2 ³ _A	ø10, ø3/8", ø12	29.5	63.5 (70)	32.5	50 (56.5)	67	55.5 (62)	55	102	57.5 (64)	71	105 (111.5)

() are the dimensions of Normally Open (N.O.).



Dimensions/Body Material: Resin (One-touch Fitting Type)

Conduit

Faston type

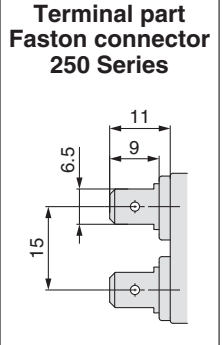
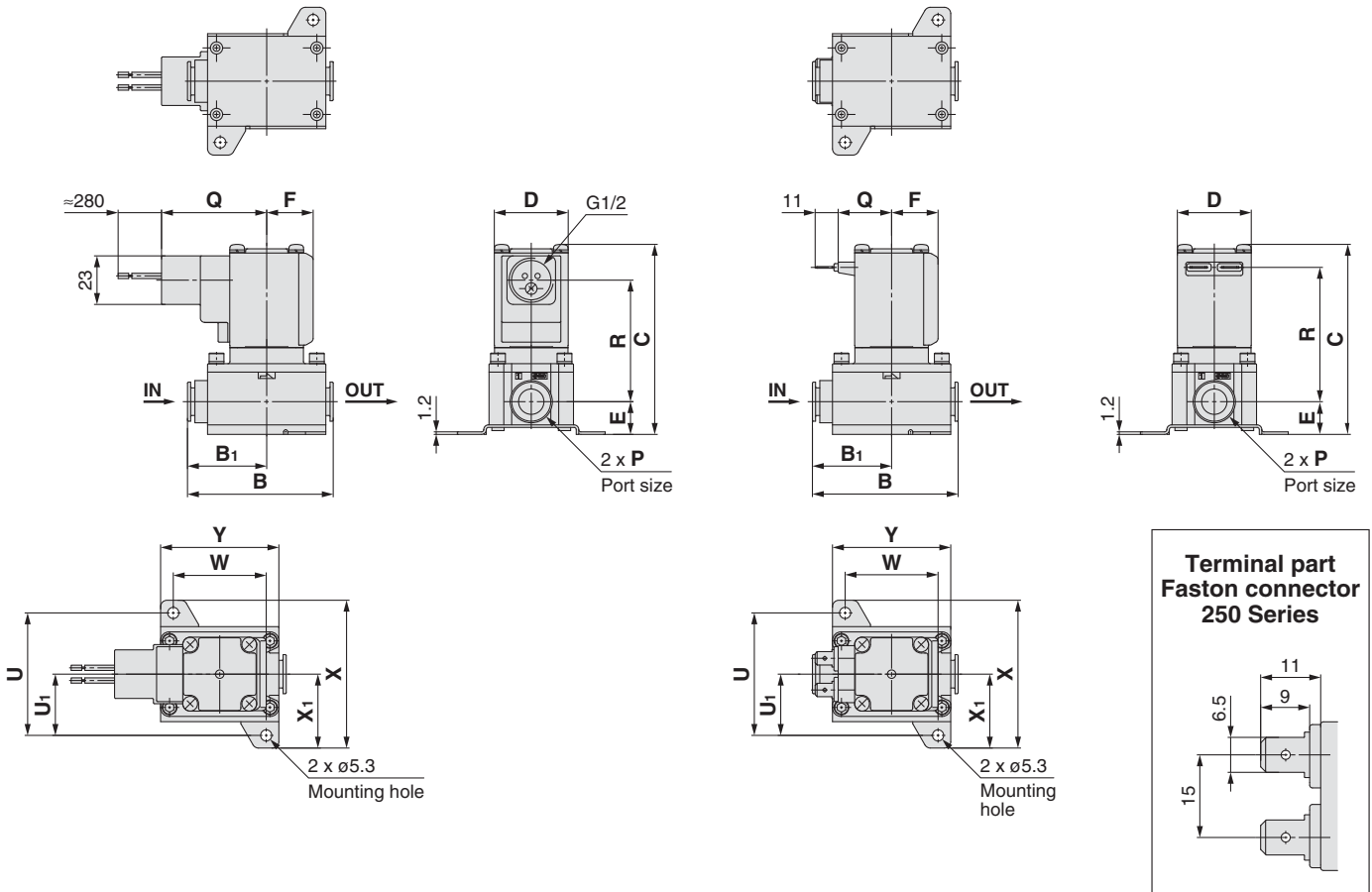

Model	One-touch fitting P	B	B ₁	C	D	E	F	Bracket mounting					
								U	U ₁	W	X	X ₁	Y
VXZ2 ³ _A	ø10, ø3/8", ø12	69	37.5	90 (96.5)	35	15.5	22	54	27	44	65	32.5	56

Model	One-touch fitting P	Electrical entry			
		Conduit		Faston	
		Q	R	Q	R
VXZ2 ³ _A	ø10, ø3/8", ø12	50	57.5 (64)	25.5	63.5 (70)

() are the dimensions of Normally Open (N.O.).

Specifications

For Air

For Water

For Oil

For Heated Water

For High Temperature Oil

Options

Construction

Dimensions

Series VXZ



For Air, Water, Oil

Dimensions/Body Material: Aluminium, C37 (Brass), Stainless Steel

Grommet

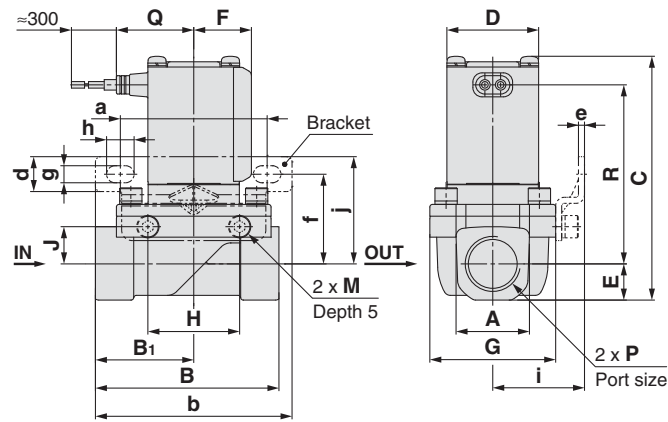

Grommet (with surge voltage suppressor)

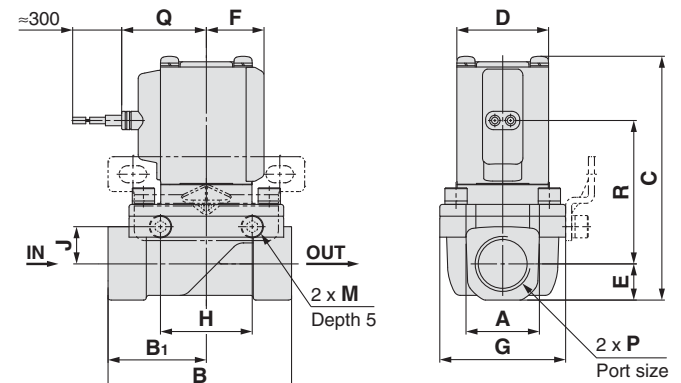

DIN terminal

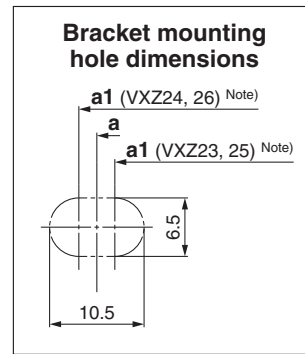
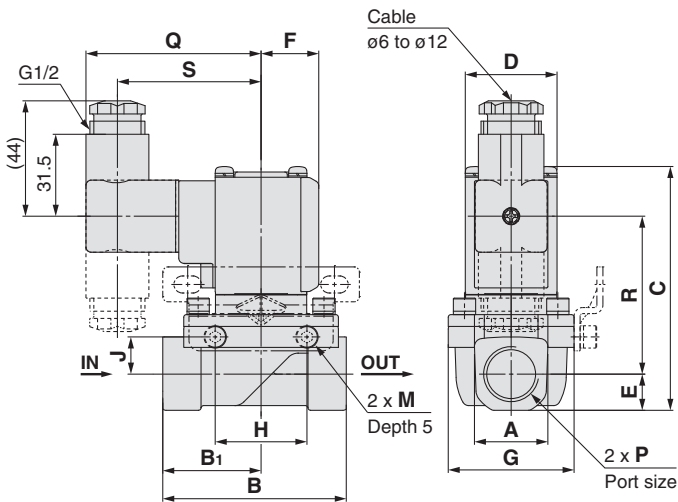

Model	Port size P	A	B	B ₁	C	D	E	F	G	H	J	M
VXZ2 ³ _A	1/4, 3/8	21 <22>	57	28.5	85 (91.5)	35	10.5	22	40	35	10	M5
VXZ2 ⁴ _B	1/2	28	70	37.5	93 (99.5)	35	14	22	48	35	14.2	M5
VXZ2 ⁵ _C	3/4	33.5	71	38.5	104 (110.5)	40	17	24.5	62	33	15.2	M6
VXZ2 ⁶ _D	1	42	95	49.5	110 (116)	40	20	24.5	66	37	17.2	M6

Model	Port size P	Bracket mounting									
		a	a ¹ (Note)	b	d	e	f	g	h	i	j
VXZ2 ³ _A	1/4, 3/8	56	52	75	13.5	2.3	30	6.5	10.5	31	37
VXZ2 ⁴ _B	1/2	56	60	75		2.3	34.5	6.5	10.5	35	41
VXZ2 ⁵ _C	3/4	70.5	68	92		2.3	39	6.5	10.5	43	46
VXZ2 ⁶ _D	1	70.5	73	92		2.3	41	6.5	10.5	45	48

Model	Port size P	Electrical entry						
		Grommet		Grommet (with surge voltage suppressor)		DIN terminal		
		Q	R	Q	R	Q	R	S
VXZ2 ³ _A	1/4, 3/8	29.5	63.5 (70)	32.5	50 (56.5)	67	55.5 (62)	55
VXZ2 ⁴ _B	1/2	29.5	68.5 (74.5)	32.5	55 (61)	67	60.5 (66.5)	55
VXZ2 ⁵ _C	3/4	32	76.5 (83)	35	63 (69.5)	69.5	68.5 (75)	57.5
VXZ2 ⁶ _D	1	32	79.5 (85)	35	66 (71.5)	69.5	71.5 (77)	57.5

() are the dimensions of Normally Open (N.O.). < > are the dimensions of aluminum body.

Note) Old VXZ bracket mounting hole center position



Dimensions/Body Material: Aluminium, C37 (Brass), Stainless Steel

Conduit terminal

Conduit

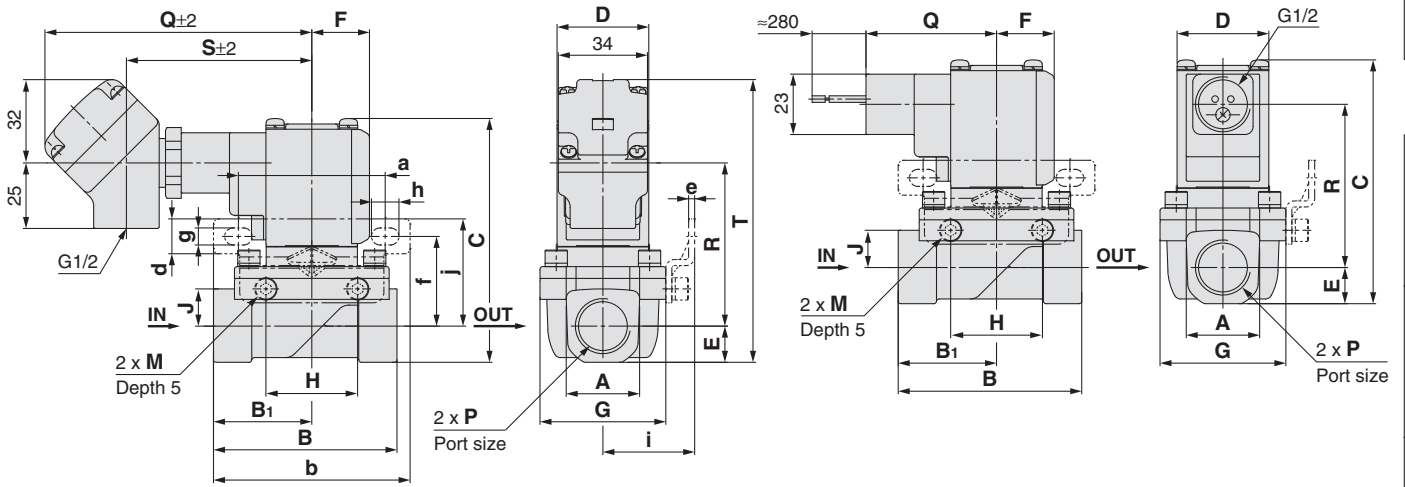

Faston type

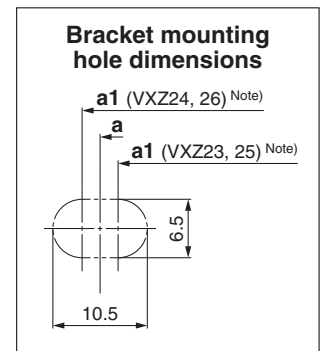
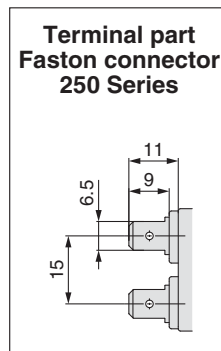
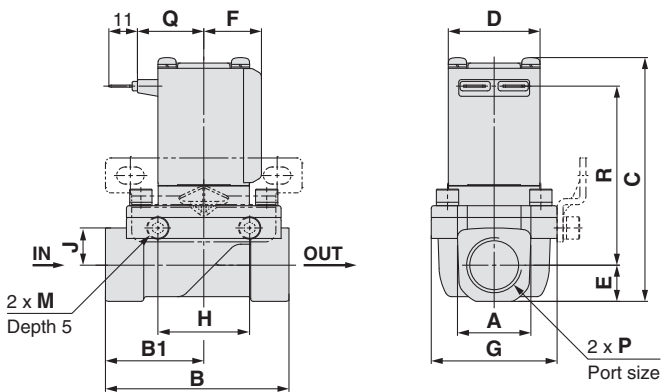

Model	Port size P	A	B	B ₁	C	D	E	F	G	H	J	M
VXZ2 ³ _A	1/4, 3/8	21 <22>	57	28.5	85 (91.5)	35	10.5	22	40	35	10	M5
VXZ2 ⁴ _B	1/2	28	70	37.5	93 (99.5)	35	14	22	48	35	14.2	M5
VXZ2 ⁵ _C	3/4	33.5	71	38.5	104 (110.5)	40	17	24.5	62	33	15.2	M6
VXZ2 ⁶ _D	1	42	95	49.5	110 (116)	40	20	24.5	66	37	17.2	M6

Model	Port size P	Bracket mounting									
		a	a1 (Note)	b	d	e	f	g	h	i	j
VXZ2 ³ _A	1/4, 3/8	56	52	75	13.5	2.3	30	6.5	10.5	31	37
VXZ2 ⁴ _B	1/2	56	60	75		2.3	34.5	6.5	10.5	35	41
VXZ2 ⁵ _C	3/4	70.5	68	92		2.3	39	6.5	10.5	43	46
VXZ2 ⁶ _D	1	70.5	73	92		2.3	41	6.5	10.5	45	48

Model	Port size P	Electrical entry							
		Conduit terminal				Conduit		Faston	
		Q	R	S	T	Q	R	Q	R
VXZ2 ³ _A	1/4, 3/8	102	57.5 (64)	71	100 (106.5)	50	57.5 (64)	25.5	63.5 (70)
VXZ2 ⁴ _B	1/2	102	62.5 (68.5)	71	108 (114.5)	50	62.5 (68.5)	25.5	68.5 (74.5)
VXZ2 ⁵ _C	3/4	104.5	70.5 (77)	73.5	119 (126)	52.5	70.5 (77)	28	76.5 (82.5)
VXZ2 ⁶ _D	1	104.5	73.5 (79)	73.5	125 (131)	52.5	73.5 (79)	28	79.5 (85)

() are the dimensions of Normally Open (N.O.). < > are the dimensions of aluminum body.
 Note) Old VXZ bracket mounting hole center position

Specifications

For Air

For Water

For Oil

For Heated Water

For High Temperature Oil

Options

Construction

Dimensions

Series VXZ



For Heated Water, High Temperature Oil

Dimensions/Body Material: C37 (Brass), Stainless Steel

Grommet

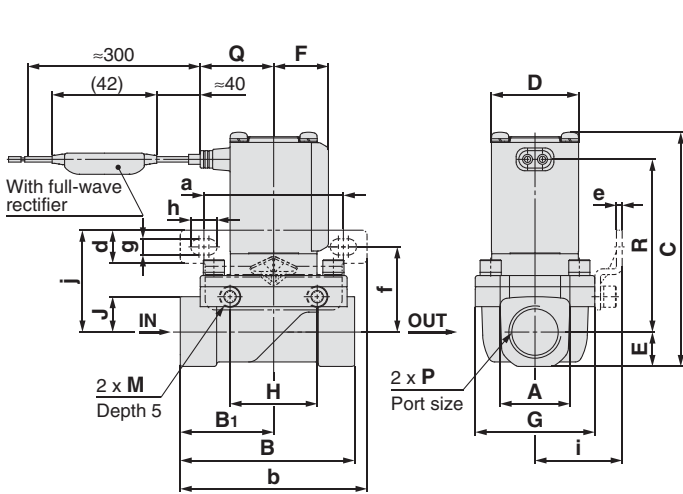

Conduit terminal

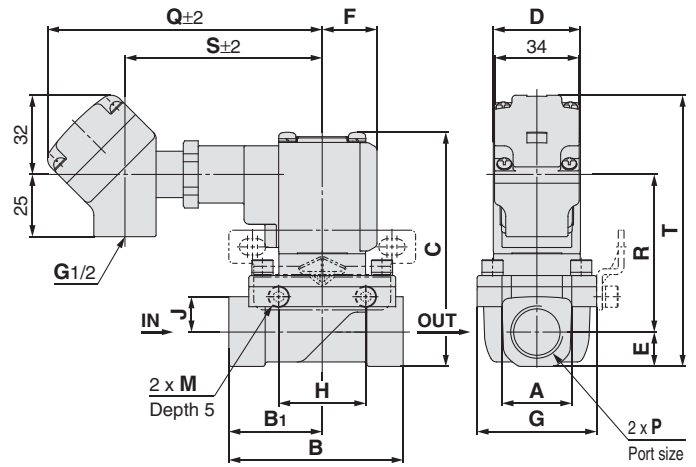

Conduit

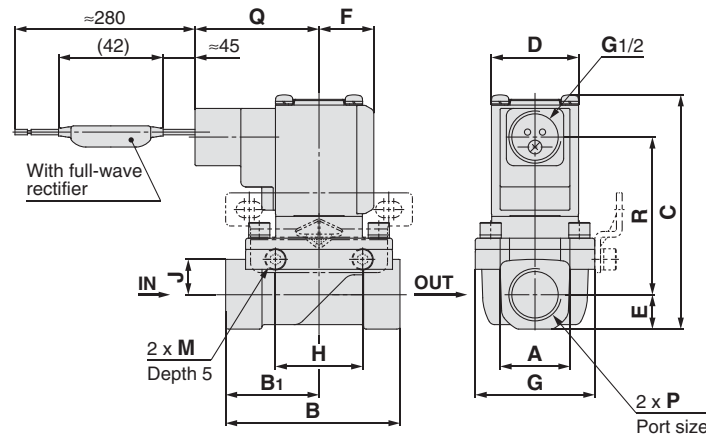

DIN terminal

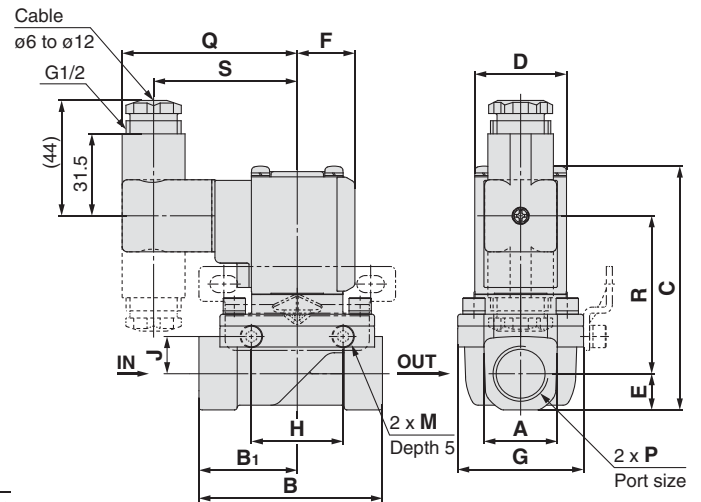

Bracket mounting hole dimensions

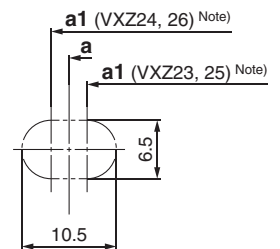

Model	Port size P	A	B	B ₁	C	D	E	F	G	H	J	M
VXZ2 ³ _A	1/4, 3/8	21	57	28.5	85 (91.5)	35	10.5	22	40	35	10	M5
VXZ2 ⁴ _B	1/2	28	70	37.5	93 (99.5)	35	14	22	48	35	14.2	M5
VXZ2 ⁵ _C	3/4	33.5	71	38.5	104 (110.5)	40	17	24.5	62	33	15.2	M6
VXZ2 ⁶ _D	1	42	95	49.5	110 (116)	40	20	24.5	66	37	17.2	M6

Model	Port size P	Bracket mounting									
		a	a ₁ (Note)	b	d	e	f	g	h	i	j
VXZ2 ³ _A	1/4, 3/8	56	52	75	13.5	2.3	30	6.5	10.5	31	37
VXZ2 ⁴ _B	1/2	56	60	75		2.3	34.5	6.5	10.5	35	41
VXZ2 ⁵ _C	3/4	70.5	68	92		2.3	39	6.5	10.5	43	46
VXZ2 ⁶ _D	1	70.5	73	92		2.3	41	6.5	10.5	45	48

Model	Port size P	Electrical entry										
		Grommet		Conduit terminal				Conduit		DIN terminal		
		Q	R	Q	R	S	T	Q	R	Q	R	S
VXZ2 ³ _A	1/4, 3/8	29.5	63.5 (70)	110.5	57.5 (64)	79.5	100 (106.5)	50	57.5 (64)	67	55.5 (62)	55
VXZ2 ⁴ _B	1/2	29.5	68.5 (74.5)	110.5	62.5 (68.5)	79.5	108 (114.5)	50	62.5 (68.5)	67	60.5 (66.5)	55
VXZ2 ⁵ _C	3/4	32	76.5 (83)	113	70.5 (77)	82	119 (126)	52.5	70.5 (77)	69.5	68.5 (75)	57.5
VXZ2 ⁶ _D	1	32	79.5 (85)	113	73.5 (79)	82	125 (131)	52.5	73.5 (79)	69.5	71.5 (77)	57.5

() are the dimensions of Normally Open (N.O.).

Note) Old VXZ bracket mounting hole center position

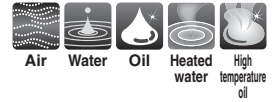

Replacement Parts

● **DIN Connector Part No.**

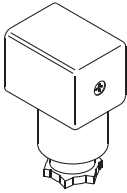

<Coil Insulation Type/For Class B>

Electrical option	Rated voltage	Connector part no.
None	24 VDC	C18312G6GCU
	12 VDC	
	100 VAC	
	110 VAC	
	200 VAC	
	220 VAC	
	230 VAC	
	240 VAC	
	24 VAC	
	48 VAC	
With light	24 VDC	GDM2A-L5
	12 VDC	GDM2A-L6
	100 VAC	GDM2A-L1
	110 VAC	GDM2A-L1
	200 VAC	GDM2A-L2
	220 VAC	GDM2A-L2
	230 VAC	GDM2A-L2
	240 VAC	GDM2A-L2
	24 VAC	GDM2A-L5
	48 VAC	GDM2A-L15

<Coil Insulation Type/For Class H>

Electrical option	Rated voltage	Connector part no.	
None	24 VDC	GDM2A-G-S2	
	100 VAC	GDM2A-R	
	110 VAC		
	200 VAC		
	220 VAC		
	230 VAC		
	240 VAC		
	24 VAC		
	48 VAC		
	With light		24 VDC
100 VAC			GDM2A-R-L1
110 VAC		GDM2A-R-L1	
200 VAC		GDM2A-R-L2	
220 VAC		GDM2A-R-L2	
230 VAC		GDM2A-R-L2	
240 VAC		GDM2A-R-L2	
24 VAC		GDM2A-R-L5	
48 VAC		GDM2A-R-L5	

● **Gasket Part No. for DIN Connector**

VCW20-1-29-1 (For Class B)

VCW20-1-29-1-F (For Class H)

● **Lead Wire Assembly for Faston Terminal
(Set of 2 pcs.)**

VX021S-1-16FB

● **Bracket Assembly Part No. (for Metal Body)**

VXZ 3 0S - 14A - 1

3	For VXZ2 $\frac{4}{3}$ A □
5	For VXZ2 $\frac{6}{5}$ C □

* 2 mounting screws are shipped together with the bracket assembly.

Glossary of Terms

Pressure Terminology

1. Maximum operating pressure differential

The maximum pressure differential (the difference between the inlet and outlet pressure) which is allowed for operation. When the outlet pressure is 0 MPa, this becomes the maximum operating pressure.

2. Minimum operating pressure differential

The minimum pressure differential (the difference between the inlet pressure and outlet pressure) required to keep the main valve fully opened.

3. Maximum system pressure

The maximum pressure that can be applied inside the pipelines (line pressure).

[The pressure differential of the solenoid valve portion must be less than the maximum operating pressure differential.]

4. Withstand pressure

The pressure in which the valve must be withstood without a drop in performance after holding for one minute under prescribed pressure and returning to the operating pressure range. [value under the prescribed conditions]

Electrical Terminology

1. Surge voltage

A high voltage which is momentarily generated by shutting off the power in the shut-off area.

2. Degree of protection

A degree defined in the “JIS C 0920: Waterproof test of electric machinery/appliance and the degree of protection against the intrusion of solid foreign objects.”

Verify the degree of protection for each product.

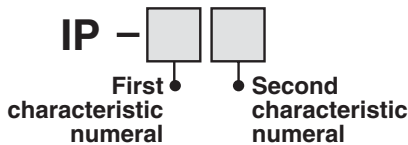

●First Characteristics: Degrees of protection against solid foreign objects

0	Non-protected
1	Protected against solid foreign objects of 50 mmø and greater
2	Protected against solid foreign objects of 12 mmø and greater
3	Protected against solid foreign objects of 2.5 mmø and greater
4	Protected against solid foreign objects of 1.0 mmø and greater
5	Dust-protected
6	Dust-tight

Electrical Terminology

●Second Characteristics: Degrees of protection against water

0	Non-protected	—
1	Protected against vertically falling water drops	Drip-proof type 1
2	Protected against vertically falling water drops when enclosure tilted up to 15°	Drip-proof type 2
3	Protected against rainfall when enclosure tilted up to 60°	Rain-proof type
4	Protected against splashing water	Splash-proof type
5	Protected against water jets	Water-jet-proof type
6	Protected against powerful water jets	Powerful water-jet-proof type
7	Protected against the effects of temporary immersion in water	Immersion type
8	Protected against the effects of continuous immersion in water	Submersible type

Example) IP65: Dust-tight, Water-jet-proof type

“Water-jet-proof type” means that no water intrudes inside an equipment that could hinder from operating normally by means of applying water for 3 minutes in the prescribed manner. Take appropriate protection measures, since a device is not usable in an environment where a droplet of water is splashed constantly.

Others

1. Material

NBR: Nitrile rubber
FKM: Fluoro rubber
EPDM: Ethylene propylene rubber

2. Oil-free treatment

The degreasing and washing of wetted parts

3. Symbol

When the valve is closed, flow is blocked from port 1 to port 2. However, if the pressure in port 2 is higher than port 1, the valve will not be able to block the fluid and it will flow from port 2 to port 1.

Faston Terminal

1. Faston™ is a trademark of Tyco Electronics Corp.
2. For electrical connection of the Faston terminal and molded coil, please use Tyco’s “Amp/Faston connector/250 Series” or the equivalent.

Solenoid Valve Flow-rate Characteristics

(How to indicate flow-rate characteristics)

1. Indication of flow-rate characteristics

The flow-rate characteristics in equipment such as a solenoid valve etc. are indicated in their specifications as shown in Table (1).

Table (1) Indication of Flow-rate Characteristics

Corresponding equipment	Indication by international standard	Other indications	Conformed standard
Pneumatic equipment	C, b	—	ISO 6358: 1989 JIS B 8390: 2000
	—	S	JIS B 8390: 2000 Equipment: JIS B 8373, 8374, 8375, 8379, 8381
		Cv	ANSI/(NFPA)T3.21.3: 1990
Process fluid control equipment	Av	—	IEC60534-2-3: 1997 JIS B 2005: 1995
	—	Cv	Equipment: JIS B 8471, 8472, 8473

2. Pneumatic equipment

2.1 Indication according to the international standards

(1) Conformed standard

ISO 6358: 1989 : Pneumatic fluid power—Components using compressible fluids—
Determination of flow-rate characteristics

JIS B 8390: 2000 : Pneumatic fluid power—Components using compressible fluids—
How to test flow-rate characteristics

(2) Definition of flow-rate characteristics

The flow-rate characteristics are indicated as a result of a comparison between sonic conductance **C** and critical pressure ratio **b**.

Sonic conductance **C** : Value which divides the passing mass flow rate of an equipment in a choked flow condition by the product of the upstream absolute pressure and the density in a standard condition.

Critical pressure ratio **b** : Pressure ratio (downstream pressure/upstream pressure) which will turn to a choked flow when the value is smaller than this ratio.

Choked flow : The flow in which the upstream pressure is higher than the downstream pressure and where sonic speed in a certain part of an equipment is reached.
Gaseous mass flow rate is in proportion to the upstream pressure and not dependent on the downstream pressure.

Subsonic flow : Flow greater than the critical pressure ratio

Standard condition : Air in a temperature state of 20°C, absolute pressure 0.1 MPa (= 100 kPa = 1 bar), relative humidity 65%.

It is stipulated by adding the "(ANR)" after the unit depicting air volume.
(standard reference atmosphere)

Conformed standard: ISO 8778: 1990 Pneumatic fluid power—Standard reference atmosphere, JIS B 8393: 2000: Pneumatic fluid power—Standard reference atmosphere

(3) Formula for flow rate

It is described by the practical units as following.

When $\frac{P_2 + 0.1}{P_1 + 0.1} \leq b$, choked flow

$$Q = 600 \times C (P_1 + 0.1) \sqrt{\frac{293}{273 + t}} \dots\dots\dots(1)$$

When $\frac{P_2 + 0.1}{P_1 + 0.1} > b$, subsonic flow

$$Q = 600 \times C (P_1 + 0.1) \sqrt{1 - \left[\frac{\frac{P_2 + 0.1}{P_1 + 0.1} - b}{1 - b} \right]^2} \sqrt{\frac{293}{273 + t}} \dots\dots\dots(2)$$

Q : Air flow rate [dm³/min (ANR)], dm³ (Cubic decimetre) of SI unit are also allowed to be described by L (litre).
1 dm³ = 1 L

C : Sonic conductance [dm³/(s·bar)]

b : Critical pressure ratio [—]

P₁ : Upstream pressure [MPa]

P₂ : Downstream pressure [MPa]

t : Temperature [°C]

Note) Formula of subsonic flow is the elliptic analogous curve.

Flow-rate characteristics are shown in Graph (1) For details, please make use of SMC's "Energy Saving Program".

Example)

Obtain the air flow rate for **P₁** = 0.4 [MPa], **P₂** = 0.3 [MPa], **t** = 20 [°C] when a solenoid valve is performed in **C** = 2 [dm³/(s·bar)] and **b** = 0.3.

According to formula 1, the maximum flow rate = $600 \times 2 \times (0.4 + 0.1) \times \sqrt{\frac{293}{273 + 20}} = 600$ [dm³/min (ANR)]

$$\text{Pressure ratio} = \frac{0.3 + 0.1}{0.4 + 0.1} = 0.8$$

Based on Graph (1), the flow rate will be 0.7 when the pressure ratio is 0.8 and **b** = 0.3.

Hence, flow rate = Maximum flow rate x flow rate ratio = 600 x 0.7 = 420 [dm³/min (ANR)]

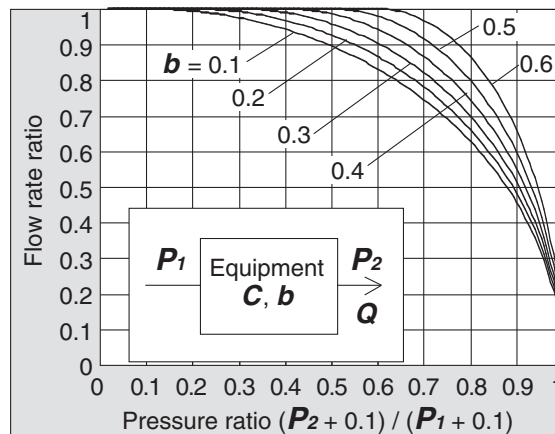

Graph (1) Flow-rate characteristics

(4) Test method

Attach a test equipment with the test circuit shown in Fig. (1) while maintaining the upstream pressure to a certain level which does not go below 0.3 MPa. Next, measure the maximum flow to be saturated in the first place, then measure this flow rate at 80%, 60%, 40%, 20% and the upstream and downstream pressure. And then, obtain the sonic conductance **C** from this maximum flow rate. Besides that, substitute each data of others for the subsonic flow formula to find **b**, then obtain the critical pressure ratio **b** from that average.

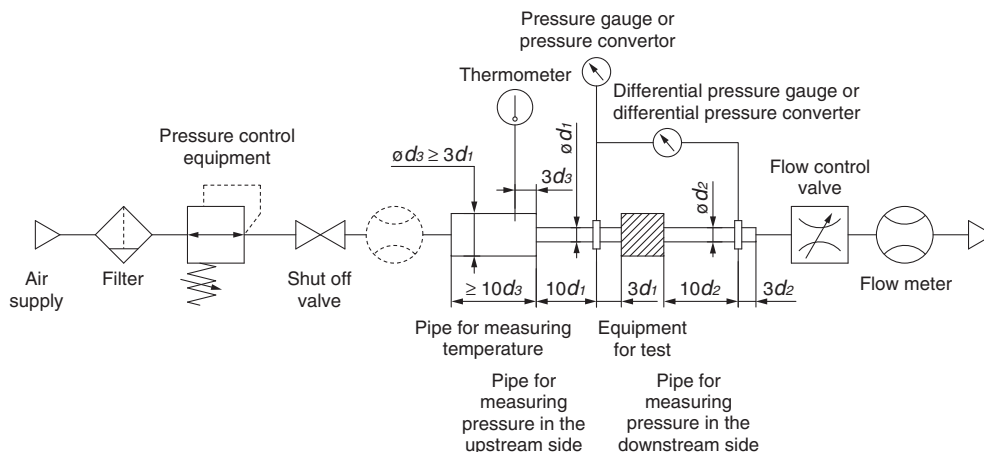

Fig. (1) Test circuit based on ISO 6358, JIS B 8390

2.2 Effective area S

(1) Conformed standard

**JIS B 8390: 2000: Pneumatic fluid power—Components using compressible fluids—
Determination of flow rate characteristics**

- Equipment standards: JIS B 8373: 2 port solenoid valve for pneumatics**
- JIS B 8374: 3 port solenoid valve for pneumatics**
- JIS B 8375: 4 port, 5 port solenoid valve for pneumatics**
- JIS B 8379: Silencer for pneumatics**
- JIS B 8381: Fittings of flexible joint for pneumatics**

(2) Definition of flow-rate characteristics

Effective area **S**: The cross-sectional area having an ideal throttle without friction deduced from the calculation of the pressure changes inside an air tank or without reduced flow when discharging the compressed air in a choked flow, from an equipment attached to the air tank. This is the same concept representing the “easy to run through” as sonic conductance **C**.

(3) Formula for flow rate

When $\frac{P_2 + 0.1}{P_1 + 0.1} \leq 0.5$, **choked flow**

$$Q = 120 \times S (P_1 + 0.1) \sqrt{\frac{293}{273 + t}} \dots\dots\dots(3)$$

When $\frac{P_2 + 0.1}{P_1 + 0.1} > 0.5$, **subsonic flow**

$$Q = 240 \times S \sqrt{(P_2 + 0.1)(P_1 - P_2)} \sqrt{\frac{293}{273 + t}} \dots\dots\dots(4)$$

Conversion with sonic conductance **C**:

$$S = 5.0 \times C \dots\dots\dots(5)$$

Q : Air flow rate[dm³/min(ANR)], dm³ (cubic decimetre) of SI unit are also allowed to be described by L (litre)
1 dm³ = 1 L

- S** : Effective area [mm²]
- P₁** : Upstream pressure [MPa]
- P₂** : Downstream pressure [MPa]
- t** : Temperature [°C]

Note) Formula for subsonic flow (4) is only applicable when the critical pressure ratio **b** is the unknown equipment. In the formula (2) by the sonic conductance **C**, it is the same formula as when **b** = 0.5.

(4) Test method

Attach a test equipment with the test circuit shown in Fig. (2) in order to discharge air into the atmosphere until the pressure inside the air tank goes down to 0.25 MPa (0.2 MPa) from an air tank filled with the compressed air at a certain pressure level (0.5 MPa) which does not go below 0.6 MPa. At this time, measure the discharging time and the residual pressure inside the air tank which had been left until it turned to be the normal values to determine the effective area **S**, using the following formula. The volume of an air tank should be selected within the specified range by corresponding to the effective area of an equipment for test. In the case of JIS B 8373, 8374, 8375, 8379, 8381, the pressure values are in parentheses and the coefficient of the formula is 12.9.

$$S = 12.1 \frac{V}{t} \log_{10} \left(\frac{P_s + 0.1}{P + 0.1} \right) \sqrt{\frac{293}{T}} \dots\dots\dots(6)$$

- S** : Effective area [mm²]
- V** : Air tank capacity [dm³]
- t** : Discharging time [s]
- P_s** : Pressure inside air tank before discharging [MPa]
- P** : Residual pressure inside air tank after discharging [MPa]
- T** : Temperature inside air tank before discharging [K]

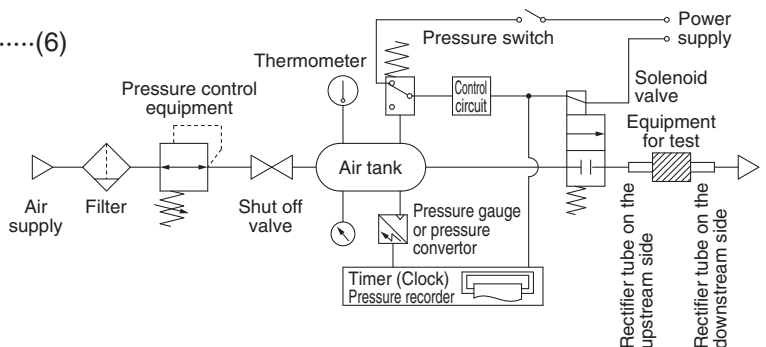

Fig. (2) Test circuit based on JIS B 8390

2.3 Flow coefficient Cv factor

The United States Standard ANSI/(NFPA)T3.21.3: 1990: Pneumatic fluid power—Flow rating test procedure and reporting method for fixed orifice components

Defines the Cv factor of flow coefficient by the following formula which is based on the test conducted by the test circuit analogous to ISO 6358.

$$Cv = \frac{Q}{114.5 \sqrt{\frac{\Delta P (P_2 + P_a)}{T_1}}} \dots\dots\dots(7)$$

ΔP : Pressure drop between the static pressure tapping ports [bar]

P_1 : Pressure of the upstream tapping port [bar gauge]

P_2 : Pressure of the downstream tapping port [bar gauge]: $P_2 = P_1 - \Delta P$

Q : Flow rate [dm³/s standard condition]

P_a : Atmospheric pressure [bar absolute]

T_1 : Upstream absolute temperature [K]

Test conditions are $< P_1 + P_a = 6.5 \pm 0.2$ bar absolute, $T_1 = 297 \pm 5$ K, $0.07 \text{ bar} \leq \Delta P \leq 0.14$ bar.

This is the same concept as effective area A which ISO 6358 stipulates as being applicable only when the pressure drop is smaller than the upstream pressure and the compression of air does not become a problem.

3. Process fluid control equipment

(1) Conformed standard

IEC60534-2-3: 1997: Industrial process control valves. Part 2: Flow capacity, Section Three-Test procedures

JIS B 2005: 1995: Test method for the flow coefficient of a valve

Equipment standards: JIS B 8471: Solenoid valve for water

JIS B 8472: Solenoid valve for steam

JIS B 8473: Solenoid valve for fuel oil

(2) Definition of flow-rate characteristics

Av factor: Value of the clean water flow rate represented by m³/s which runs through a valve (equipment for test) when the pressure difference is 1 Pa. It is calculated using the following formula.

$$Av = Q \sqrt{\frac{\rho}{\Delta P}} \dots\dots\dots(8)$$

Av : Flow coefficient [m²]

Q : Flow rate [m³/s]

ΔP : Pressure difference [Pa]

ρ : Fluid density [kg/m³]

(3) Formula of flow rate

It is described by the practical units. Also, the flow-rate characteristics are shown in Graph (2).

In the case of liquid:

$$Q = 1.9 \times 10^6 Av \sqrt{\frac{\Delta P}{G}} \dots\dots\dots(9)$$

Q : Flow rate [L/min]

Av : Flow coefficient [m²]

ΔP : Pressure difference [MPa]

G : Relative density [water = 1]

In the case of saturated aqueous vapor:

$$Q = 8.3 \times 10^6 Av \sqrt{\Delta P (P_2 + 0.1)} \dots\dots\dots(10)$$

Q : Flow rate [kg/h]

Av : Flow coefficient [m²]

ΔP : Pressure difference [MPa]

P₁ : Upstream pressure [MPa]: $\Delta P = P_1 - P_2$

P₂ : Downstream pressure [MPa]

Conversion of flow coefficient:

$$Av = 28 \times 10^{-6} Kv = 24 \times 10^{-6} Cv \dots\dots\dots(11)$$

Here,

Kv factor : Value of the clean water flow rate represented by m³/h which runs through a valve at 5 to 40°C, when the pressure difference is 1 bar.

Cv factor (Reference values): Figures representing the flow rate of clean water by US gal/min which runs through a valve at 60°F, when the pressure difference is 1 lbf/in² (psi).

Value is different from **Kv** and **Cv** factors for pneumatic purpose due to different test method.

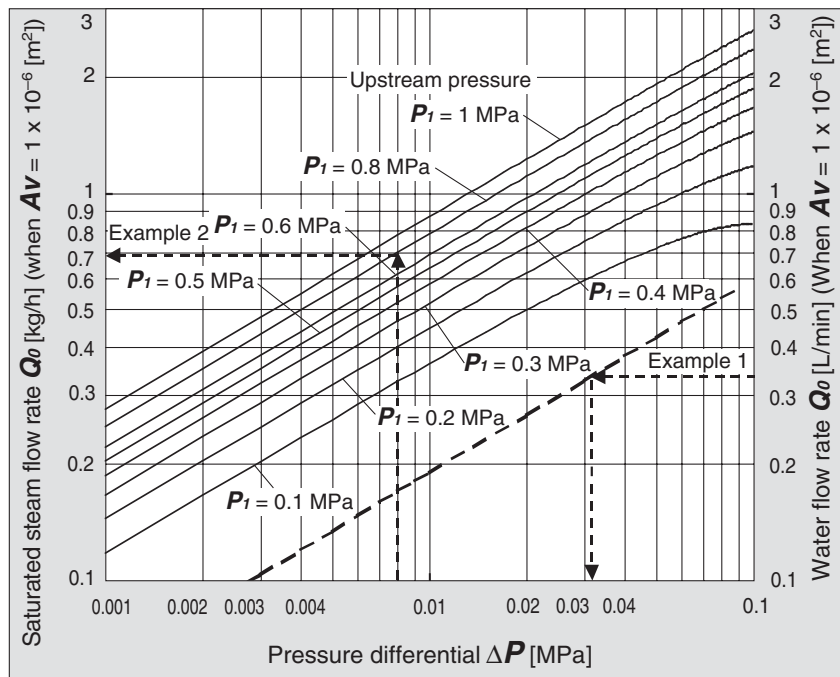

Graph (2) Flow-rate characteristics

Example 1)

Obtain the pressure difference when water 15 [L/min] runs through a solenoid valve with an **Av** = 45 x 10⁻⁶ [m²]. Since **Q₀** = 15/45 = 0.33 [L/min], according to Graph (2), if reading **ΔP** when **Q₀** is 0.33, it will be 0.031 [MPa].

Example 2)

Obtain the saturated steam flow rate when **P₁** = 0.8 [MPa], **ΔP** = 0.008 [MPa] with a solenoid valve with an **Av** = 1.5 x 10⁻⁶ [m²].

According to Graph (2), if reading **Q₀** when **P₁** is 0.8 and **ΔP** is 0.008, it is 0.7 [kg/h]. Hence, the flow rate **Q** = 0.7 x 1.5 = 1.05 [kg/h].

(4) Test method

Attach a test equipment with the test circuit shown in Fig. (3). Next, pour water at 5 to 40°C, then measure the flow rate with a pressure difference of 0.075 MPa. However, the pressure difference needs to be set with a large enough difference so that the Reynolds number does not go below a range of 4 x 10⁴.

By substituting the measurement results for formula (8) to figure out **Av**.

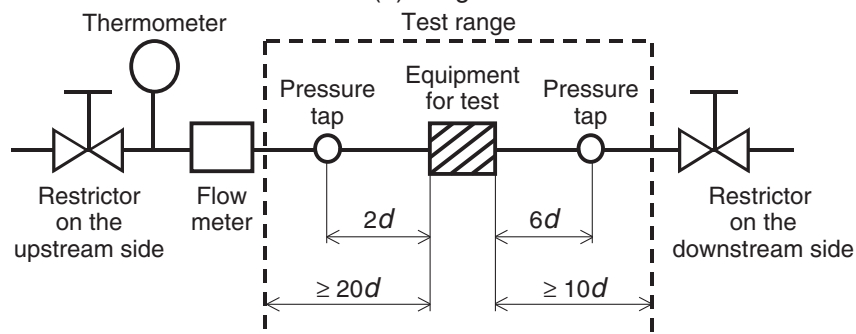

Fig. (3) Test circuit based on IEC60534-2-3, JIS B 2005

Series VXZ

Flow-rate Characteristics

Note) Use this graph as a guide. In the case of obtaining an accurate flow rate, refer to pages 31 through to 35.

For Air

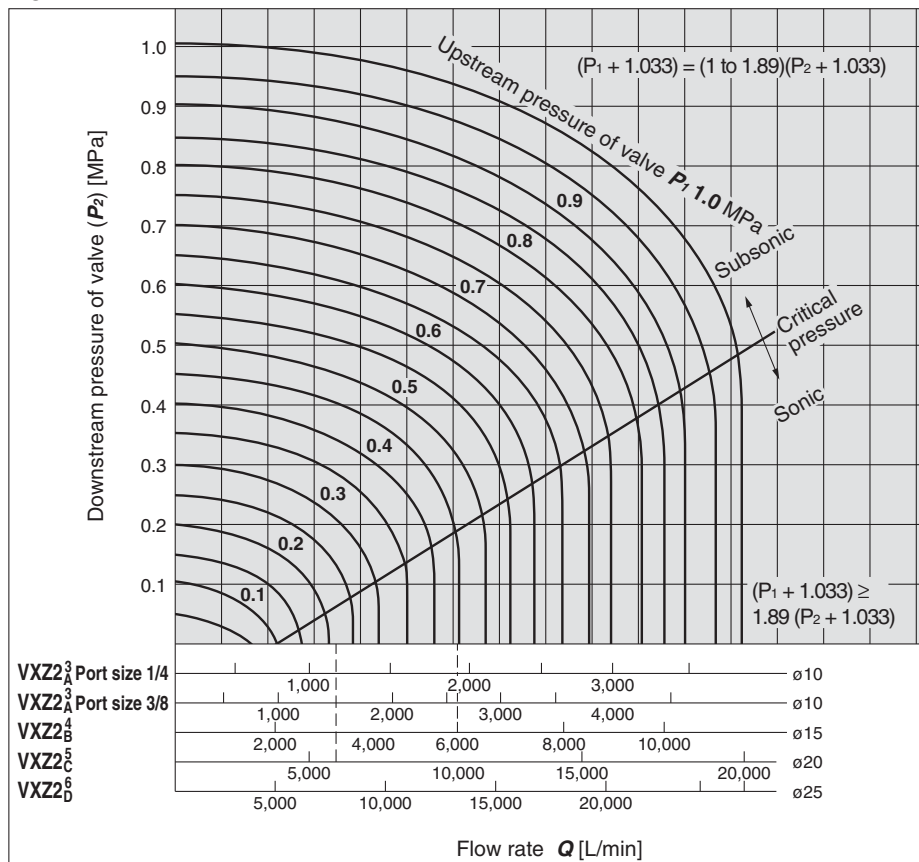

How to read the graph

The sonic range pressure to generate a flow of 6,000 L/min (ANR) is $P_1 \approx 0.47$ MPa for a $\phi 15$ orifice (VXZ2_B⁴) and $P_1 \approx 0.23$ MPa for a $\phi 20$ orifice (VXZ2_C⁵).

The optimum size for an upstream pressure $P_1 = 0.45$ MPa and a flow of 6,000 L/min will be the VXZ2_B⁴ ($\phi 15$ orifice, port size 1/2).

For Water

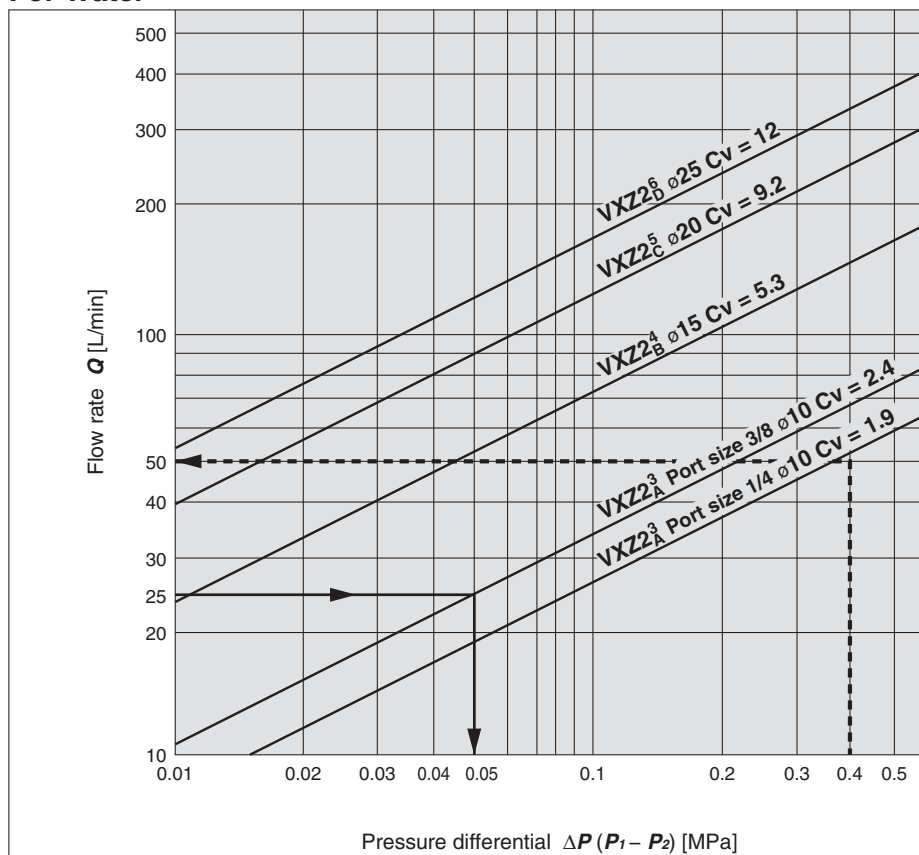

How to read the graph

The pressure differential for a $\phi 10$ orifice to supply a flow of 25 L/min (VXZ2_A³, port size 3/8) will be $\Delta P \approx 0.05$ MPa.

The optimum size for a pressure differential of $\Delta P \approx 0.4$ MPa and a flow of 50 L/min will be the VXZ2_A³ ($\phi 10$ orifice, port size 1/4).



Series VXZ

Specific Product Precautions 1

Be sure to read before handling. Refer to back cover for Safety Instructions, "Handling Precautions for SMC Products" (M-E03-3) and the Operation Manual for 2 Port Solenoid Valves for Fluid Control Precautions. Please download it via our website, <http://www.smcworld.com>

Design

Warning

1. Cannot be used as an emergency shutoff valve etc.

The valves presented in this catalogue are not designed for safety applications such as an emergency shutoff valve. If the valves are used in this type of system, other reliable safety assurance measures should also be adopted.

2. Extended periods of continuous energization

The solenoid coil will generate heat when continuously energized. Avoid using in a tightly shut container. Install it in a well ventilated area. Furthermore, do not touch it while it is being energized or right after it is energized.

3. Liquid rings

In cases with a flowing liquid, provide a bypass valve in the system to prevent the liquid from entering the liquid seal circuit.

4. Actuator drive

When an actuator, such as a cylinder, is to be driven using a valve, take appropriate measures to prevent potential danger caused by actuator operation.

5. Pressure (including vacuum) holding

It is not usable for an application such as holding the pressure (including vacuum) inside of a pressure vessel because air leakage is entailed in a valve.

6. When the conduit type is used as equivalent to an IP65 enclosure, install a wiring conduit etc.

7. When an impact, such as water hammer etc., caused by the rapid pressure fluctuation is applied, the solenoid valve may be damaged. Give an attention to it.

Selection

Warning

1. Usage with low flow

Unstable flow may occur with the product under the following conditions: • low flow from the pump or compressor, etc. • use of several elbows or tees in the circuit, or • thin nozzles installed at the end of the piping etc. This can cause valve opening/closing failure, or oscillation, and cause a valve malfunction.

Please check the pressure differential and flow to select the appropriate size of the valve referring to the Flow-rate Characteristics on page 34. Ensure that pressure differential does not become lower than 0.01 MPa during ON (N.C.: Valve open).

Selection

Warning

2. Fluid

1) Type of fluid

Select an appropriate valve with reference to the table below for the general fluid. Before using a fluid, check whether it is compatible with the materials of each model by referring to the fluids listed in this catalogue. Use a fluid with a kinematic viscosity of 50 mm²/s or less.

If there is something you do not know, please contact SMC.

Applicable Fluid

For Air	Air
For Water	Air, Water
For Oil	Air, Water, Oil
For Heated water	Air(up to 99°C), Water, Heated water
For High temperature oil	Air(up to 99°C), Water, Oil, High temperature oil

2) Flammable oil, Gas

"Confirm the specification for leakage in the interior and/or exterior area."

3) Corrosive gas

Cannot be used since it will lead to cracks by stress corrosion or result in other incidents.

4) When a brass body is used, then depending on water quality, corrosion and internal leakage may occur. If such abnormalities occur, exchange the product for a stainless steel body.

5) Use an oil-free specification when any oily particle must not enter the passage.

6) Applicable fluid on the list may not be used depending on the operating condition. Give adequate confirmation, and then determine a model, just because the compatibility list shows the general case.

3. Air quality

<Air>

1) Use clean air.

Do not use compressed air that contains chemicals, synthetic oils including organic solvents, salt or corrosive gases, etc., as it can cause damage or malfunction.

2) Install an air filter.

Install air filters close to valves at their upstream side. filtration degree of 5 μm or less should be selected.

3) Install an aftercooler or air dryer, etc.

Compressed air that contains excessive drainage may cause malfunction of valves and other pneumatic equipment. To prevent this, install an aftercooler or air dryer, etc.

4) If excessive carbon powder is generated, eliminate it by installing mist separators at the upstream side of valves.

If excessive carbon powder is generated by the compressor, it may adhere to the inside of the valves and cause a malfunction.



Series VXZ

Specific Product Precautions 2

Be sure to read before handling. Refer to back cover for Safety Instructions, "Handling Precautions for SMC Products" (M-E03-3) and the Operation Manual for 2 Port Solenoid Valves for Fluid Control Precautions. Please download it via our website, <http://www.smcworld.com>

Selection

Warning

<Water>

The use of a fluid that contains foreign objects can cause problems such as malfunction and seal failure by promoting wear of the valve seat and armature, and by sticking to the sliding parts of the armature etc. Install a suitable filter (strainer) immediately upstream from the valve. As a general rule, use 100 mesh.

The supply water includes materials that create a hard sediment or sludge such as calcium and magnesium. Since this scale and sludge can cause the valve to malfunction, install water softening equipment, and a filter (strainer) directly upstream from the valve to remove these substances.

Tap water pressure:

The water pressure for tap water is normally 0.4 MPa or less. However, in places like a high-rise building, the pressure may be 1.0 MPa. When selecting tap water, be careful of the maximum operating pressure differential.

When using water or heated water, poor operation or leaks may be caused by dezincification, erosion, corrosion, etc.

The brass (C37) body of this product uses dezincification resistant material as a standard. We also offer a stainless steel body type with improved corrosion resistance. Please use the one that fits your needs.

<Oil>

Generally, FKM is used as seal material, as it is resistant to oil. The resistance of the seal material may deteriorate depending on the type of oil, manufacturer or additives.

Check the resistance before using.

<Vacuum>

Please be aware that there is a range of pressure that can be used.

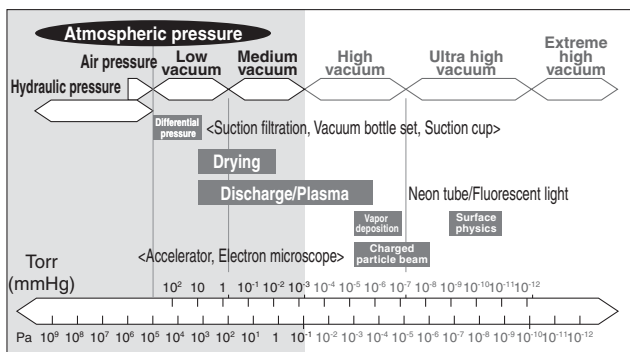

Vacuum piping direction: if the system uses a vacuum pump, we ask that you install the vacuum pump on the secondary side.

Also, install a filter on the primary side, and be careful that no foreign object is picked up.

Please replace the valve after operating the device approximately 300,000 times.

4. Ambient environment

Use within the operable ambient temperature range. Check the compatibility between the product's composition materials and the ambient atmosphere. Be certain that the fluid used does not touch the external surface of the product.

5. Countermeasures against static electricity

Take measures to prevent static electricity since some fluids can cause static electricity.

Caution

1. Leakage voltage

Particularly when using a resistor in parallel with a switching element and using a C-R element (surge voltage suppressor) to protect the switching element, take note that leakage current will flow through the resistor, C-R element, etc., creating a possible danger that the valve may not turn off.

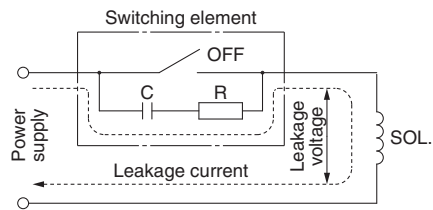

AC/Class B built-in full-wave rectifier coil: 10% or less of rated voltage
DC coil: 2% or less of rated voltage

2. Selecting model

Material depends on fluid. Select optimal models for the fluid.

3. When the fluid is oil.

The kinematic viscosity must not exceed 50 mm²/s.

Mounting

Warning

1. If air leakage increases or equipment does not operate properly, stop operation.

After mounting is completed, confirm that it has been done correctly by performing a suitable function test.

2. Do not apply external force to the coil section.

When tightening is performed, apply a wrench or other tool to the outside of the piping connection parts.

3. Mount a valve with its coil position upward, not downward.

When mounting a valve with its coil positioned downward, foreign objects in the fluid will adhere to the iron core leading to a malfunction.

4. Do not warm the coil assembly with a heat insulator etc.

Use tape, heaters, etc., for freeze prevention on the piping and body only. They can cause the coil to burn out.

5. Secure with brackets, except in the case of steel piping and copper fittings.



Series VXZ

Specific Product Precautions 3

Be sure to read before handling. Refer to back cover for Safety Instructions, "Handling Precautions for SMC Products" (M-E03-3) and the Operation Manual for 2 Port Solenoid Valves for Fluid Control Precautions. Please download it via our website, <http://www.smcworld.com>

Mounting

Warning

6. Avoid sources of vibration, or adjust the arm from the body to the minimum length so that resonance will not occur.

7. Painting and coating

Warnings or specifications printed or labelled on the product should not be erased, removed or covered up.

Piping

Warning

1. During use, deterioration of the tube or damage to the fittings could cause tubes to come loose from their fittings and thrash about.

To prevent uncontrolled tube movement, install protective covers or fasten tubes securely in place.

2. For piping the tube, fix the product securely using the mounting holes so that the product is not in the air.

Caution

1. Preparation before piping

Before piping is connected, it should be thoroughly blown out with air (flushing) or washed to remove chips, cutting oil and other debris from inside the pipe. Avoid pulling, compressing, or bending the valve body when piping.

2. Avoid connecting ground lines to piping, as this may cause electric corrosion of the system.

3. Always tighten threads with the proper tightening torque.

When attaching fittings to valves, tighten with the proper tightening torque shown below.

Lower tightening torque will lead into fluid leakage.

Tightening Torque for Piping

Connection threads	Proper tightening torque N·m
Rc1/8	3 to 5
Rc1/4	8 to 12
Rc3/8	15 to 20
Rc1/2	20 to 25
Rc3/4	
Rc1	36 to 38

4. Connection of piping to products

When connecting piping to a product, avoid mistakes regarding the supply port etc.

5. Wrapping of pipe tape

When connecting pipes, fittings, etc., be sure that chips from the pipe threads and sealing material do not enter the valve.

Furthermore, when pipe tape is used, leave 1.5 to 2 thread ridges exposed at the end of the threads.

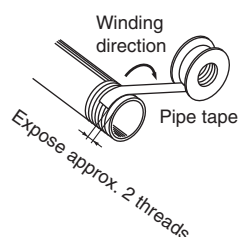

Piping

Caution

6. If a regulator and valve are connected directly, they may vibrate together and cause chattering. Do not connect directly.

7. If the cross-sectional area of piping for the fluid supply side is restricted, operation will become unstable due to inadequate pressure differential during valve operation. Use piping size for the fluid supply side that is suited to the port size.

Recommended Piping Conditions

1. When connecting tubes using One-touch fittings, provide some spare tube length shown in Fig. 1, recommended piping configuration.

Also, do not apply external force to the fittings when binding tubes with bands etc. (see Fig. 2.)

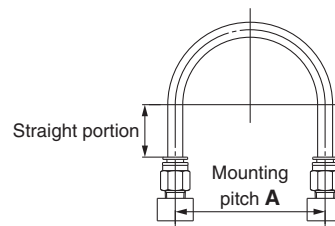

Fig. 1 Recommended piping configuration

Unit: mm

Tubing size	Mounting pitch A			Straight portion length
	Nylon tubing	Soft nylon tubing	Polyurethane tubing	
ø1/8"	44 or more	29 or more	25 or more	16 or more
ø6	84 or more	39 or more	39 or more	30 or more
ø1/4"	89 or more	56 or more	57 or more	32 or more
ø8	112 or more	58 or more	52 or more	40 or more
ø10	140 or more	70 or more	69 or more	50 or more
ø12	168 or more	82 or more	88 or more	60 or more

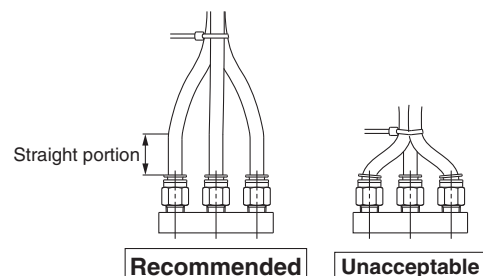

Fig. 2 Binding tubes with bands



Series VXZ

Specific Product Precautions 4

Be sure to read before handling. Refer to back cover for Safety Instructions, "Handling Precautions for SMC Products" (M-E03-3) and the Operation Manual for 2 Port Solenoid Valves for Fluid Control Precautions. Please download it via our website, <http://www.smcworld.com>

Wiring

Warning

1. Do not apply AC voltage to Class "H" coil AC type unless it is built in full-wave rectifier, or the coil will be damaged.

Caution

1. As a rule, use electrical wire with a cross sectional area of 0.5 to 1.25 mm² for wiring. Furthermore, do not allow excessive force to be applied to the lines.
2. Use electrical circuits which do not generate chattering in their contacts.
3. Use voltage which is within $\pm 10\%$ of the rated voltage. In cases with a DC power supply where importance is placed on responsiveness, stay within $\pm 5\%$ of the rated value. The voltage drop is the value in the lead wire section connecting the coil.
4. When a surge from the solenoid affects the electrical circuitry, install a surge voltage suppressor etc., in parallel with the solenoid. Or, adopt an option that comes with the surge voltage protection circuit. (However, a surge voltage occurs even if the surge voltage protection circuit is used. For details, please consult with SMC.)

Operating Environment

Warning

1. Do not use in an atmosphere having corrosive gases, chemicals, sea water, water, water steam, or where there is direct contact with any of these.
2. Do not use in explosive atmospheres.
3. Do not use in locations subject to vibration or impact.
4. Do not use in locations where radiated heat will be received from nearby heat sources.
5. Employ suitable protective measures in locations where there is contact with water droplets, oil or welding spatter, etc.

Maintenance

Warning

1. Removing the product

The valve will reach a high temperature when used with high temperature fluids. Confirm that the valve temperature has dropped sufficiently before performing work. If touched inadvertently, there is a danger of being burned.

- 1) Shut off the fluid supply and release the fluid pressure in the system.
- 2) Shut off the power supply.
- 3) Dismount the product.

2. Low frequency operation

Switch valves at least once every 30 days to prevent malfunction. Also, in order to use it under the optimum state, conduct a regular inspection once a half year.

Caution

1. Filters and strainers

- 1) Be careful regarding clogging of filters and strainers.
- 2) Replace filter elements after one year of use, or earlier if the pressure drop reaches 0.1 MPa.
- 3) Clean strainers when the pressure drop reaches 0.1 MPa.

2. Lubrication

When using after lubricating, never forget to lubricate continuously.

3. Storage

In case of long term storage after use, thoroughly remove all moisture to prevent rust and deterioration of rubber materials etc.

4. Exhaust the drain from an air filter periodically.

Operating Precautions

Warning

1. If there is a possibility of reverse pressure being applied to the valve, take countermeasures such as mounting a check valve on the downstream side of the valve.
2. When problems are caused by a water hammer, install water hammer relief equipment (accumulator etc.), or use an SMC water hammer relief valve (Series VXR). Please consult with SMC for details.
3. For pilot type 2-port solenoid valves, when the valve is closed, sudden pressure resulting from the startup of the fluid supply source (pump, compressor, etc.) may cause the valve momentarily to open and leakage to occur, so please exercise caution.
4. If the product is used in the conditions in which rapid decrease in the inlet pressure of the valve and rapid increase in the outlet pressure of the valve are repeated, excessive stress will be applied to the diaphragm, which causes the diaphragm to be damaged and dropped, leading to the operation failure of the valve. Check the operating conditions before use.



Series VXZ Specific Product Precautions 5

Be sure to read before handling. Refer to back cover for Safety Instructions, "Handling Precautions for SMC Products" (M-E03-3) and the Operation Manual for 2 Port Solenoid Valves for Fluid Control Precautions. Please download it via our website, <http://www.smcworld.com>

Electrical Connections

⚠ Caution

■ Grommet

Class B coil: AWG20 Insulator O.D. 2.5 mm
Class H coil: AWG18 Insulator O.D. 2.1 mm

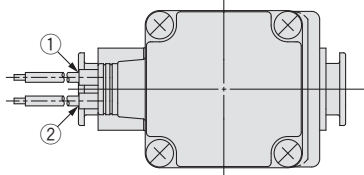

Rated voltage	Lead wire colour	
	①	②
DC	Black	Red
100 VAC	Blue	Blue
200 VAC	Red	Red
Other AC	Grey	Grey

* There is no polarity.

■ DIN terminal

Since internal connections are as shown below for the DIN terminal, make connections to the power supply accordingly.

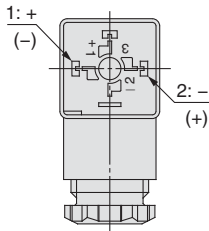

Terminal no.	1	2
DIN terminal	+ (-)	- (+)

* There is no polarity.
· Use compatible heavy duty cords with cable O.D. of $\phi 6$ to 12 mm.
· Use the tightening torques below for each section.

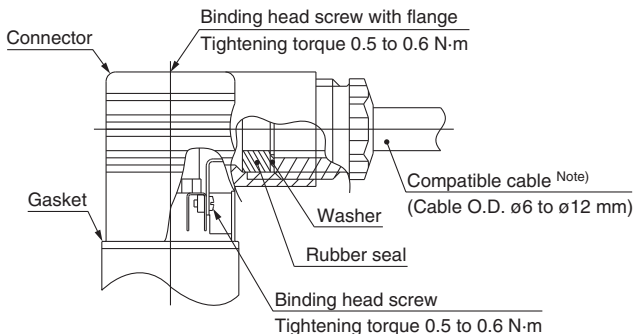

Note) For an outside cable diameter of $\phi 9$ to 12 mm, remove the internal parts of the rubber seal before using.

[Change of electrical entry]

Wire entry can be changed by mounting the housing in either direction (four directions at every 90°) after dividing the terminal block and the housing.

* For the indicator lighted style, be careful not to damage the light with the lead wire of the cable.

■ Conduit terminal

In the case of the conduit terminal, make connections according to the marks shown below.

- Use the tightening torques below for each section.
- Properly seal the terminal connection (G1/2) with the special wiring conduit etc.

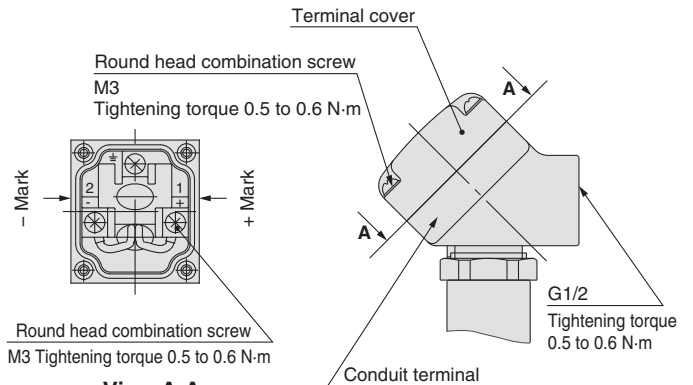

View A-A
(Internal connection diagram)

■ Conduit

When used as an IP65 equivalent, use seal to install the wiring conduit. Also, use the tightening torque below for the conduit.

Class B coil: AWG20 Insulator O.D. 2.5 mm
Class H coil: AWG18 Insulator O.D. 2.1 mm

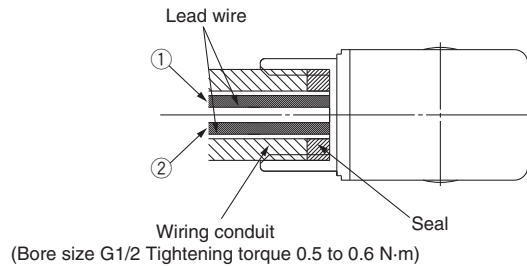

Rated voltage	Lead wire colour	
	①	②
DC	Black	Red
100 VAC	Blue	Blue
200 VAC	Red	Red
Other AC	Grey	Grey

* There is no polarity.
(For the power saving type, there is polarity.)

Description	Part no.
Seal	VCW20-15-6

Note) Please order separately.



Series VXZ

Specific Product Precautions 6

Be sure to read before handling. Refer to back cover for Safety Instructions, "Handling Precautions for SMC Products" (M-E03-3) and the Operation Manual for 2 Port Solenoid Valves for Fluid Control Precautions. Please download it via our website, <http://www.smcworld.com>

Electrical Circuits

⚠ Caution

[DC circuit]

Grommet, Faston terminal

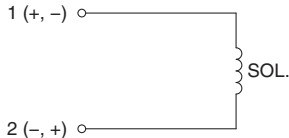

Without electrical option

Grommet, DIN terminal, Conduit terminal, Conduit

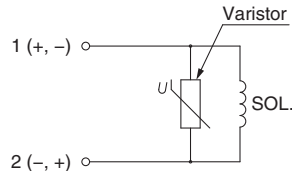

With surge voltage suppressor

DIN terminal, Conduit terminal

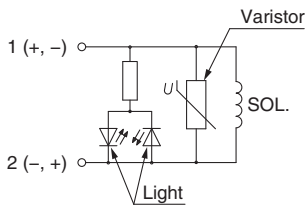

With light/surge voltage suppressor

[AC circuit]

Grommet, DIN terminal, Conduit terminal, Conduit

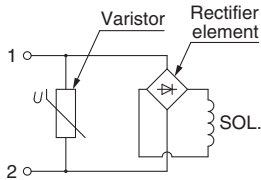

Without electrical option

DIN terminal, Conduit terminal

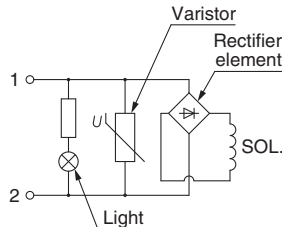

With light/surge voltage suppressor



One-touch Fitting

⚠ Caution

For information on handling One-touch fittings and appropriate tubing, refer the KQ2 series One-touch fittings in SMC website, <http://www.smc.eu>

Safety Instructions

These safety instructions are intended to prevent hazardous situations and/or equipment damage. These instructions indicate the level of potential hazard with the labels of “**Caution**,” “**Warning**” or “**Danger**.” They are all important notes for safety and must be followed in addition to International Standards (ISO/IEC)*1), and other safety regulations.

-  **Caution:** **Caution** indicates a hazard with a low level of risk which, if not avoided, could result in minor or moderate injury.
-  **Warning:** **Warning** indicates a hazard with a medium level of risk which, if not avoided, could result in death or serious injury.
-  **Danger:** **Danger** indicates a hazard with a high level of risk which, if not avoided, will result in death or serious injury.

- *1) ISO 4414: Pneumatic fluid power – General rules relating to systems.
- ISO 4413: Hydraulic fluid power – General rules relating to systems.
- IEC 60204-1: Safety of machinery – Electrical equipment of machines. (Part 1: General requirements)
- ISO 10218-1: Manipulating industrial robots - Safety. etc.

Warning

- 1. The compatibility of the product is the responsibility of the person who designs the equipment or decides its specifications.**
Since the product specified here is used under various operating conditions, its compatibility with specific equipment must be decided by the person who designs the equipment or decides its specifications based on necessary analysis and test results. The expected performance and safety assurance of the equipment will be the responsibility of the person who has determined its compatibility with the product. This person should also continuously review all specifications of the product referring to its latest catalogue information, with a view to giving due consideration to any possibility of equipment failure when configuring the equipment.
- 2. Only personnel with appropriate training should operate machinery and equipment.**
The product specified here may become unsafe if handled incorrectly. The assembly, operation and maintenance of machines or equipment including our products must be performed by an operator who is appropriately trained and experienced.
- 3. Do not service or attempt to remove product and machinery/equipment until safety is confirmed.**
 1. The inspection and maintenance of machinery/equipment should only be performed after measures to prevent falling or runaway of the driven objects have been confirmed.
 2. When the product is to be removed, confirm that the safety measures as mentioned above are implemented and the power from any appropriate source is cut, and read and understand the specific product precautions of all relevant products carefully.
 3. Before machinery/equipment is restarted, take measures to prevent unexpected operation and malfunction.
- 4. Contact SMC beforehand and take special consideration of safety measures if the product is to be used in any of the following conditions.**
 1. Conditions and environments outside of the given specifications, or use outdoors or in a place exposed to direct sunlight.
 2. Installation on equipment in conjunction with atomic energy, railways, air navigation, space, shipping, vehicles, military, medical treatment, combustion and recreation, or equipment in contact with food and beverages, emergency stop circuits, clutch and brake circuits in press applications, safety equipment or other applications unsuitable for the standard specifications described in the product catalogue.
 3. An application which could have negative effects on people, property, or animals requiring special safety analysis.
 4. Use in an interlock circuit, which requires the provision of double interlock for possible failure by using a mechanical protective function, and periodical checks to confirm proper operation.

Caution

- 1. The product is provided for use in manufacturing industries.**
The product herein described is basically provided for peaceful use in manufacturing industries.
If considering using the product in other industries, consult SMC beforehand and exchange specifications or a contract if necessary.
If anything is unclear, contact your nearest sales branch.

Limited warranty and Disclaimer/ Compliance Requirements

The product used is subject to the following “Limited warranty and Disclaimer” and “Compliance Requirements”.

Read and accept them before using the product.

Limited warranty and Disclaimer

1. The warranty period of the product is 1 year in service or 1.5 years after the product is delivered.*2)
Also, the product may have specified durability, running distance or replacement parts. Please consult your nearest sales branch.
2. For any failure or damage reported within the warranty period which is clearly our responsibility, a replacement product or necessary parts will be provided.
This limited warranty applies only to our product independently, and not to any other damage incurred due to the failure of the product.
3. Prior to using SMC products, please read and understand the warranty terms and disclaimers noted in the specified catalogue for the particular products.

*2) Vacuum pads are excluded from this 1 year warranty.

A vacuum pad is a consumable part, so it is warranted for a year after it is delivered. Also, even within the warranty period, the wear of a product due to the use of the vacuum pad or failure due to the deterioration of rubber material are not covered by the limited warranty.

Compliance Requirements

1. The use of SMC products with production equipment for the manufacture of weapons of mass destruction (WMD) or any other weapon is strictly prohibited.
2. The exports of SMC products or technology from one country to another are governed by the relevant security laws and regulations of the countries involved in the transaction. Prior to the shipment of a SMC product to another country, assure that all local rules governing that export are known and followed.

Safety Instructions

Be sure to read “Handling Precautions for SMC Products” (M-E03-3) before using.

SMC Corporation (Europe)

Austria	+43 (0)2262622800	www.smc.at	office@smc.at
Belgium	+32 (0)33551464	www.smc-pneumatics.be	info@smc-pneumatics.be
Bulgaria	+359 (0)2807670	www.smc.bg	office@smc.bg
Croatia	+385 (0)13707288	www.smc.hr	office@smc.hr
Czech Republic	+420 541424611	www.smc.cz	office@smc.cz
Denmark	+45 70252900	www.smc.dk.com	smc@smcdk.com
Estonia	+372 6510370	www.smc-pneumatics.ee	smc@smc-pneumatics.ee
Finland	+358 207513513	www.smc.fi	smc.fi@smc.fi
France	+33 (0)164761000	www.smc-france.fr	promotion@smc-france.fr
Germany	+49 (0)61034020	www.smc-pneumatik.de	info@smc-pneumatik.de
Greece	+30 210 2717265	www.smc-hellas.gr	sales@smc-hellas.gr
Hungary	+36 23511390	www.smc.hu	office@smc.hu
Ireland	+353 (0)14039000	www.smc-pneumatics.ie	sales@smc-pneumatics.ie
Italy	+39 02922711	www.smc-italia.it	mailbox@smc-italia.it
Latvia	+371 67817700	www.smc.lv	info@smc.lv

Lithuania	+370 5 2308118	www.smclt.lt	info@smclt.lt
Netherlands	+31 (0)205318888	www.smc-pneumatics.nl	info@smc-pneumatics.nl
Norway	+47 67129020	www.smc-norge.no	post@smc-norge.no
Poland	+48 (0)222119616	www.smc.pl	office@smc.pl
Portugal	+351 226166570	www.smc.eu	postpt@smc.smces.es
Romania	+40 213205111	www.smcromania.ro	smcromania@smcromania.ro
Russia	+7 8127185445	www.smc-pneumatik.ru	info@smc-pneumatik.ru
Slovakia	+421 (0)413213212	www.smc.sk	office@smc.sk
Slovenia	+386 (0)73885412	www.smc.si	office@smc.si
Spain	+34 902184100	www.smc.eu	post@smc.smces.es
Sweden	+46 (0)86031200	www.smc.nu	post@smc.nu
Switzerland	+41 (0)523963131	www.smc.ch	info@smc.ch
Turkey	+90 212 489 0 440	www.smc-pneumatik.com.tr	info@smc-pneumatik.com.tr
UK	+44 (0)845 121 5122	www.smc-pneumatics.co.uk	sales@smc-pneumatics.co.uk