

MR Unit (Regulator with Mist Separator) AMR3000 to 6000

Standard Specifications

Model	AMR3000	AMR4000	AMR5000	AMR6000
Port size	1/4, 3/8	1/4, 3/8, 1/2	1/2, 3/4	3/4, 1
Fluid	Air			
Proof pressure	1.5MPa			
Max. operating pressure	1.0MPa			
Min. operating pressure ⁽¹⁾	0.05MPa			
Setting pressure range	0.05 to 0.85MPa			
Ambient and fluid temperature	-5 to 60°C (No freezing)			
Construction	Relieving style			
Filtration	0.3µm			
Oil mist density on the secondary side	Max. 1.0mgf/Nm ³ (≒ 0.8ppm) ⁽²⁾ / ₍₃₎			
Rated flow (ℓ/min (ANR)) ⁽⁴⁾	750	1500	3500	6000
Weight (kg)	1.8	2.8	3.5	6.7

Note 1) Pressure for auto drain attached style should be set at 0.1MPa or higher. Note 2) Compressed air density: 30mgf/Nm³. Note 3) Grease is used on the parts of regulator.
Note 4) Supply pressure: 0.7MPa
Be careful not to supply more air than rated amount, it might cause oil flow into the secondary side.

Accessories (Standard)/Part No.

Description	Model	AMR3000	AMR4000	AMR5000	AMR6000
Bracket		13576	13556	13587	13568
Gauge ⁽⁵⁾	1.0MPa	G36-10-□01		G46-10-□02	

Accessories (Options)/Part No.

Description	Model	AMR3000	AMR4000	AMR5000	AMR6000
Adapter assembly ⁽⁶⁾		1/4: E3-□02 3/8: E3-□03	1/4: E4-□02 3/8: E4-□03 1/2: E4-□04	1/2: E5-□04 3/4: E5-□06	3/4: E6-□06 1: E6-□10
Float style auto drain (Bowl assembly)		AD33-X203	AD33-X202	AD33-X210	AD33-X201
Compact pressure switch		IS1000-01 (Set at 0.4MPa)			
PT elbow ⁽⁷⁾		135510		135613	

Note 5) □ in the gauge part number (e.g. G36-10-□01) indicates thread.
No symbol for "Rc(PT)" and "N" for "NPT". Consult SMC, if "NPT" gauge is required.
Note 6) Piping adapter, O ring, Hexagon socket bolt, Hexagon socket bolt ass'y. These are shipped together with products. □ in the gauge part number indicates thread. No symbol for "Rc(PT)", "N" for "NPT" and "F" for "G(PF)".
Note 7) To mount a compact pressure switch from the back, PT elbow is needed.

**Mist Separator and Regulator
are combined together.
High Filtration (0.3µm)
Space saving and Easy piping.**



Compact Pressure Switch Specifications (Refer to p.3.10-1 for further information.)

Model	IS1000-01			
Set pressure range (OFF)	0.1 to 0.4MPa			
Differential	0.08MPa			
Contact point construction	1a			
Max. contact point capacity	2VA AC, 2W DC			
Voltage (AC, DC)	12V	24V	48V	100V
Max. current	50mA	50mA	40mA	20mA
Operating time	1.2ms			
Shock resistance	30G			

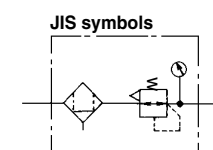

Regulator with Mist Separator **AMR3000 to 6000**

How to Order

AMR 4 0 00 - 03 S E3 - R

- MR unit**
- Auto drain**

0	None
1	With auto drain
- Body size**

3	3/8 standard
4	1/2 standard
5	3/4 standard
6	1 standard
- Thread**

—	Rc(PT)
N	NPT
F	G(PF)
- Pressure switch**

—	None
S	With pressure switch
- Port size**

Symbol	Port size	Applicable model
02	1/4	AMR3000/4000
03	3/8	AMR3000/4000
04	1/2	AMR4000/5000
06	3/4	AMR5000/6000
10	1	AMR6000
- Additional symbol**

—	Flow direction: left to right
R	Flow direction: right to left
- Adapter ass'y port size (2 pcs.)**

—	None
E2	1/4
E3	3/8
E4	1/2
E6	3/4
E10	1

* The port size of adapter ass'y is same as the port size of the body.

Adapter Assembly (part number for one piece)

E 3 - 02

- Applicable model**

3	AMR3□00-02 to 03
4	AMR4□00-02 to 04
5	AMR5□00-04 to 06
6	AMR6□00-10
- Port size**

02	1/4
03	3/8
04	1/2
06	3/4
10	1
- Thread**

—	Rc (PT)
N	NPT
F	G (PF)

Construction

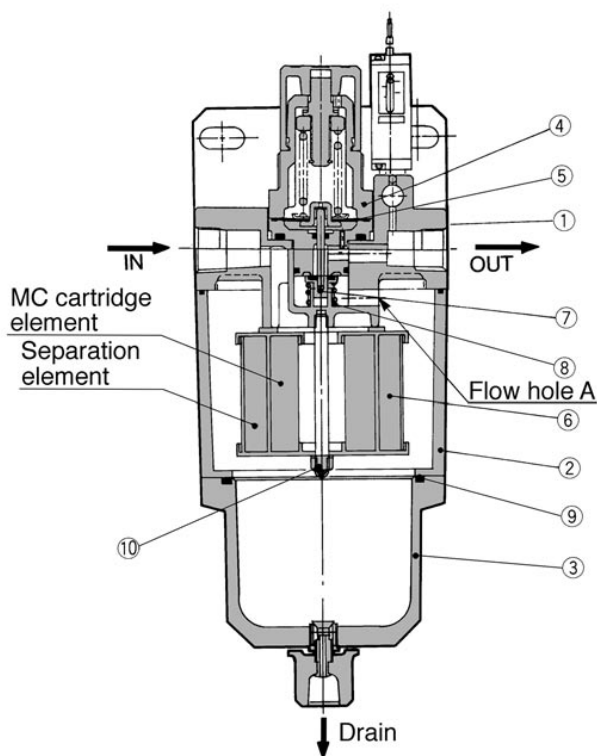

Operation Principle

The compressed air from the air source passes from the IN side through the top of element 6 and flows inward. The compressed air that flowed in passes through the MC cartridge element provided inside element 6, where all dust that is larger than 0.3μm is removed. Then, the mist is arrested by inertial collision, direct interception, and dissipation through Brownian movement on the surface and the inside of the filtering fibers of the external separation element. The mist then coagulates to form a large drop, becomes separated from the compressed air, accumulates in case 3, and is discharged through the drain valve. Meanwhile, the clean compressed air in housing 2 passes through flow hole A of body 1, it is reduced to a specified pressure by the pressure reducing valve, and is discharged from the OUT side.

Auto drain style

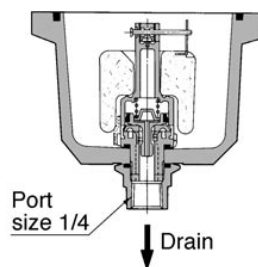

Component Parts

No.	Description	Model			
		AMR3000	AMR4000	AMR5000	AMR6000
①	Body	Aluminum alloy			
②	Housing	Aluminum alloy			
③	Bowl	Aluminum alloy			
④	Bonnet	Polyacetal		Aluminum alloy	

Replacement Parts

No.	Description	Material	Part No.			
			AMR3000	AMR4000	AMR5000	AMR6000
⑤	Diaphragm ass'y	—	1349161A	131515A	131515A	131614A
⑥	Element (1)	—	13579	135511	13589	13569
⑦	Valve ass'y	Brass	135711A	13154A	135811A	135614-1A
⑧	Valve spring	Stainless steel	135011	131514	131613	135413
⑨	O ring	NBR	G75	G90	G100	G115
⑩	Gasket	Fiber	135714	635327	635327	63555

Note 1) The MC cartridge element and the separation element are integrated.

AMR3000 to 6000

Flow characteristics

Condition: Supply pressure 0.7MPa

AMR3000/3100

Rc(PT) ¼

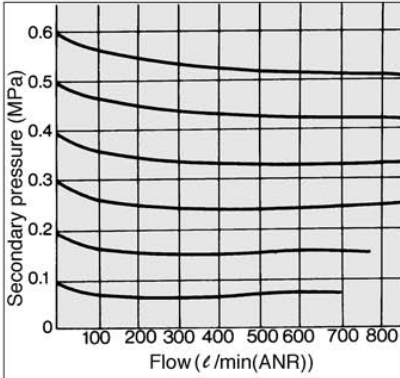

AMR4000/4100

Rc(PT) ⅜

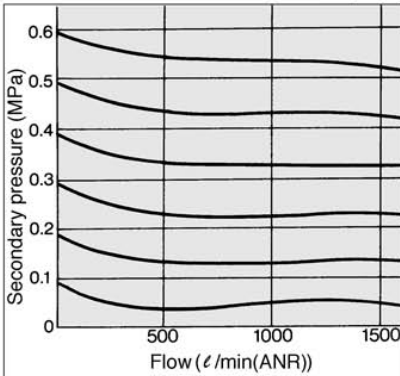

AMR5000/5100

Rc(PT) ½

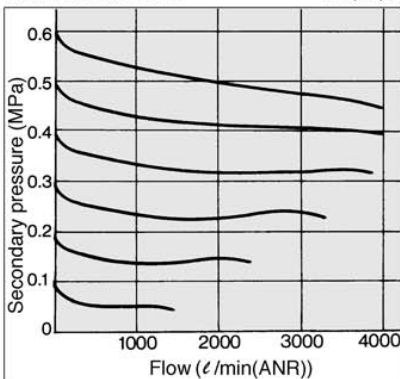

AMR6000/6100

Rc(PT) 1

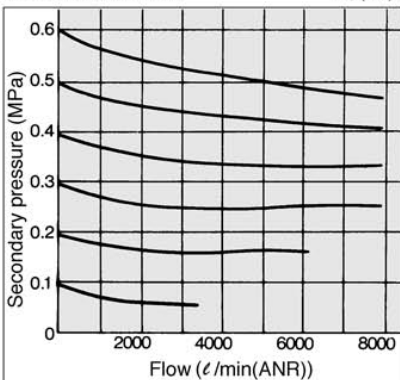

Pressure characteristics

Conditions: Supply pressure 0.7MPa, Secondary pressure 0.2MPa
Flow 20l/min (ANR)

AMR3000/3100

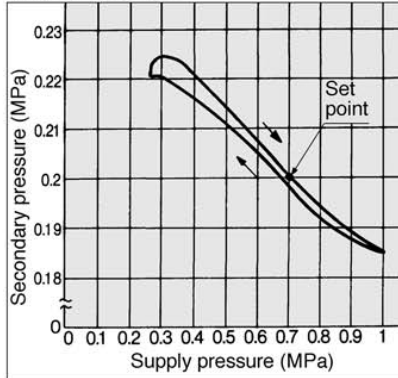

AMR4000/4100

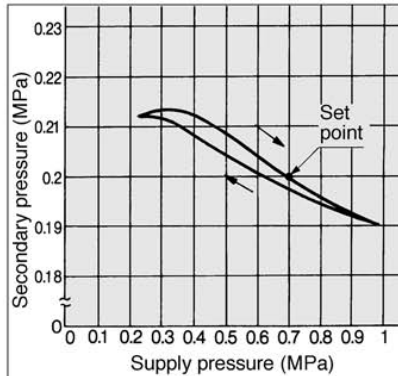

AMR5000/5100

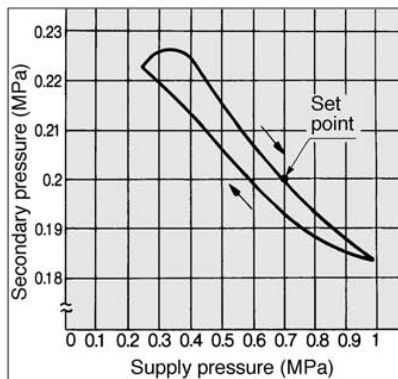

AMR6000/6100

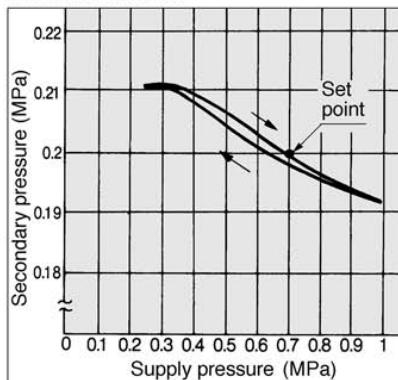

⚠ Precautions

Be sure to read before handling.
Refer to p.0-26 and 0-27 for Safety Instructions and common precautions on the products mentioned in this catalogue, and refer to p.1.0-2 and 1.0-3 for precautions on every series.

Selection

⚠ Warning

- ① The residual secondary pressure cannot be released by releasing the supply pressure. To release the residual pressure, contact SMC.

Installation and Adjustment

⚠ Warning

- ① Do not place a magnetic object near the pressure switch to prevent unintended operation.
- ② Do not expose the pressure switch to strong shocks (over 300m/s²) to prevent the switch from damage.
- ③ The adjustment handle must be operated manually. Using a tool to turn the handle could lead to damage.

⚠ Caution

- ① Release the lock to adjust the pressure. After the adjustment, engage the lock. Failure to observe this procedure could damage the handle or cause the secondary pressure to fluctuate.
- 1) On the AMR3000 type, pull the adjustment handle to release the lock and push the handle to engage the lock. If it does not lock easily, turn the handle slightly clockwise or counterclockwise before pushing it.
- 2) On the AMR4000 to 6000 types, pull the adjustment handle to release the lock. (An orange coloured line is provided at the bottom of the adjustment handle for visual checking.) Push the adjustment handle to engage the lock. If it does not lock easily, turn the handle slightly clockwise or counterclockwise; then, push it until the orange coloured line is no longer visible.



Orange mark

Maintenance Inspection

⚠ Warning

- ① Replace the filter element within 2 years of operation or before the pressure drop reaches 0.1MPa. Failure to observe this precaution could damage the filter element.

Regulator with Mist Separator **AMR3000 to 6000**

Dimensions

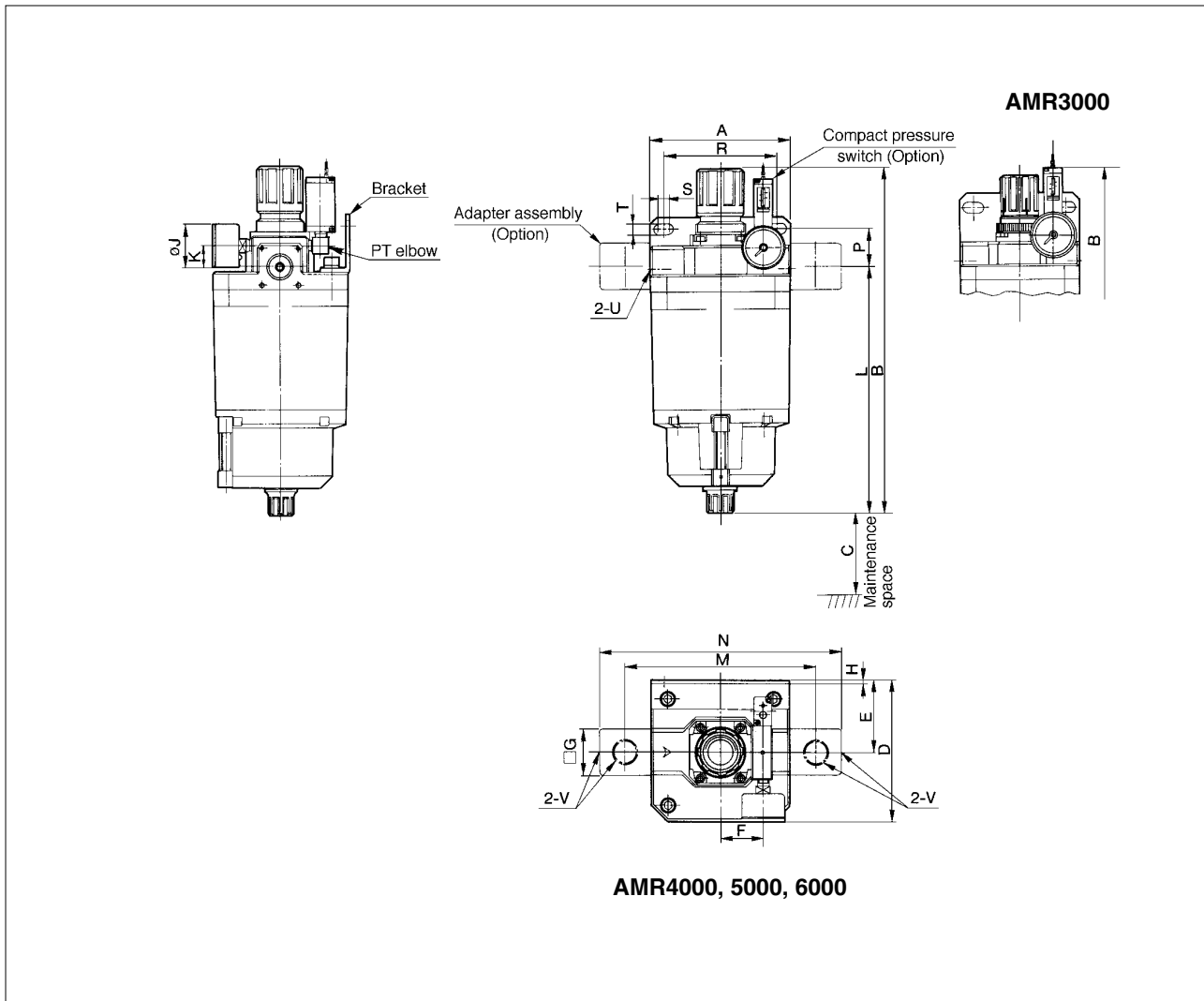

Model	Port size		A	B	C	D	E	F	G	H	J	K	L	M	N	Bracket mounting dimension				With auto drain	
	U (Body)	V (Adapter)														P	R	S	T	B	L
AMR3000	1/4, 3/8	1/4, 3/8	100	264	10	103	51	28	32	3.2	37	21.5	182	144	180	50	78	8	9	260	178
AMR4000	1/4, 3/8, 1/2	1/4, 3/8, 1/2	120	302	10	121	61	37	40	3.2	37	18	215	166	210	35	97	7	9	298	211
AMR5000	1/2, 3/4	1/2, 3/4	130	370	70	131	66	37	48	4.5	42	16	281	188	246	45	98	10	11	366	277
AMR6000	3/4, 1	3/4, 1	160	436	70	161	81	44	56	4.5	42	18.5	325	230	290	46.5	115	15	11	432	321

Accessory/Compact pressure switch: IS1000-01 (Refer to page 3.10-1 for further information.)

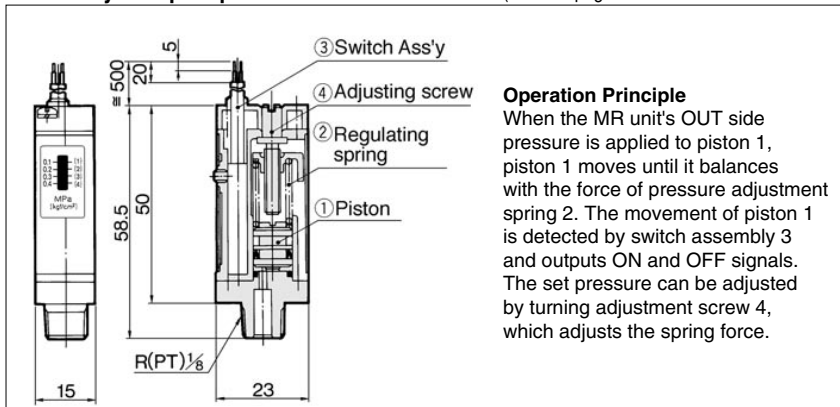

Adapter assembly installation procedure

- ① Install the O ring in the O ring groove of the adapter.
- ② Orient the adapter port to the desired direction.
- ③ Using a hexagon wrench, tighten the four hexagon socket head bolts to install the adapter.
- ④ Screw in the hexagon socket head cap into the unused port of the adapter.

