

Cylinder with Lock

Ø 32, Ø 40, Ø 50, Ø 63, Ø 80, Ø 100

New

RoHS

Lock can be manually operated with a hexagon wrench.

Can be easily mounted onto equipment

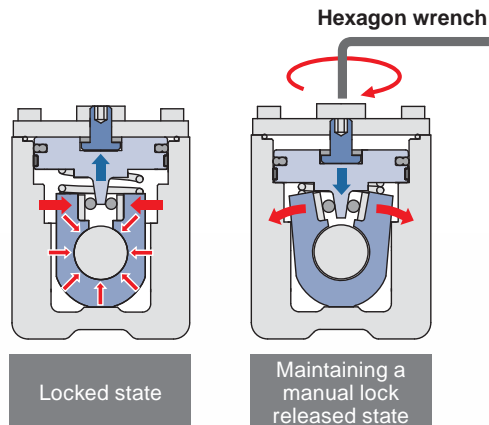

The lock unit and the cylinder can be separated. Improved ease of maintenance



Holding force improved by **15 %**

(C(P)95N, Ø 50: 1370 N → **C(P)96N: 1570 N**)

Stopping accuracy within **±1 mm**

(With Ø 50 and 30 kg of load)

Overall length reduced by

27.5 mm max.

(Compared with a C(P)95N, Ø 100, 100 mm stroke)

Lock Unit

Applicable rod size: Ø 12 to Ø 30



CP96N/C96N Series



CAT.EUS20-259A-UK

A locking cylinder ideal for intermediate stops,

- Built-in manual lock release holding mechanism
- It is possible to release the locked state with a hexagon wrench and hold the released state without pressurizing the unlock port.
- Simple construction

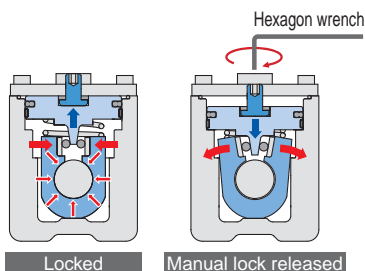

- The condition of the lock release bolt allows for visual confirmation of whether the cylinder is in a locked or manual lock released state.

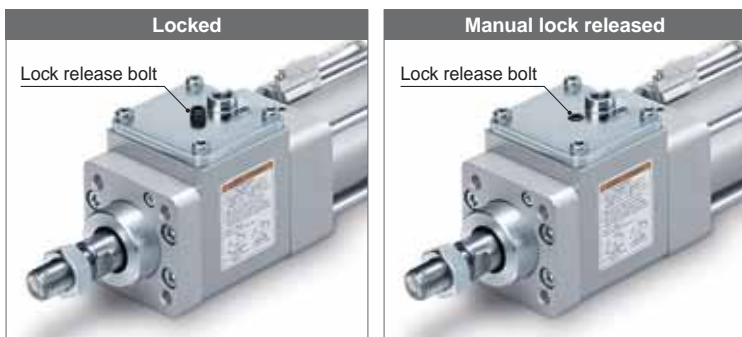

Refer to page 52 for the manual lock release.

Overall length reduced by **27.5 mm max.**

Up to 27.5 mm shorter compared with the C(P)95N series

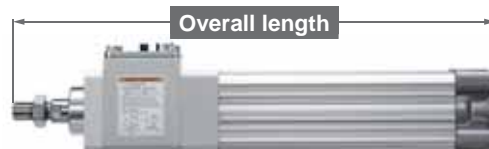

Overall length reduced [mm]

Bore size [mm]	C(P)96N	C(P)95N	Reduction
32	204	216	12
40	229	240	11
50	254	268	14
63	273.5	297	23.5
80	328	349	21
100	356.5	384	27.5

* For basic type dimensions

Improved holding force

Improved by up to **15 %** compared with the C(P)95N series

Improved holding force [N]

Bore size [mm]	C(P)96N	C(P)95N	Increase rate [%]
32	630	552	14
40	980	882	11
50	1570	1370	15
63	2450	2160	13
80	3920	3430	14
100	6080	5390	13

Unlock port

When pressurised: Unlocked
When exhausted: Locked

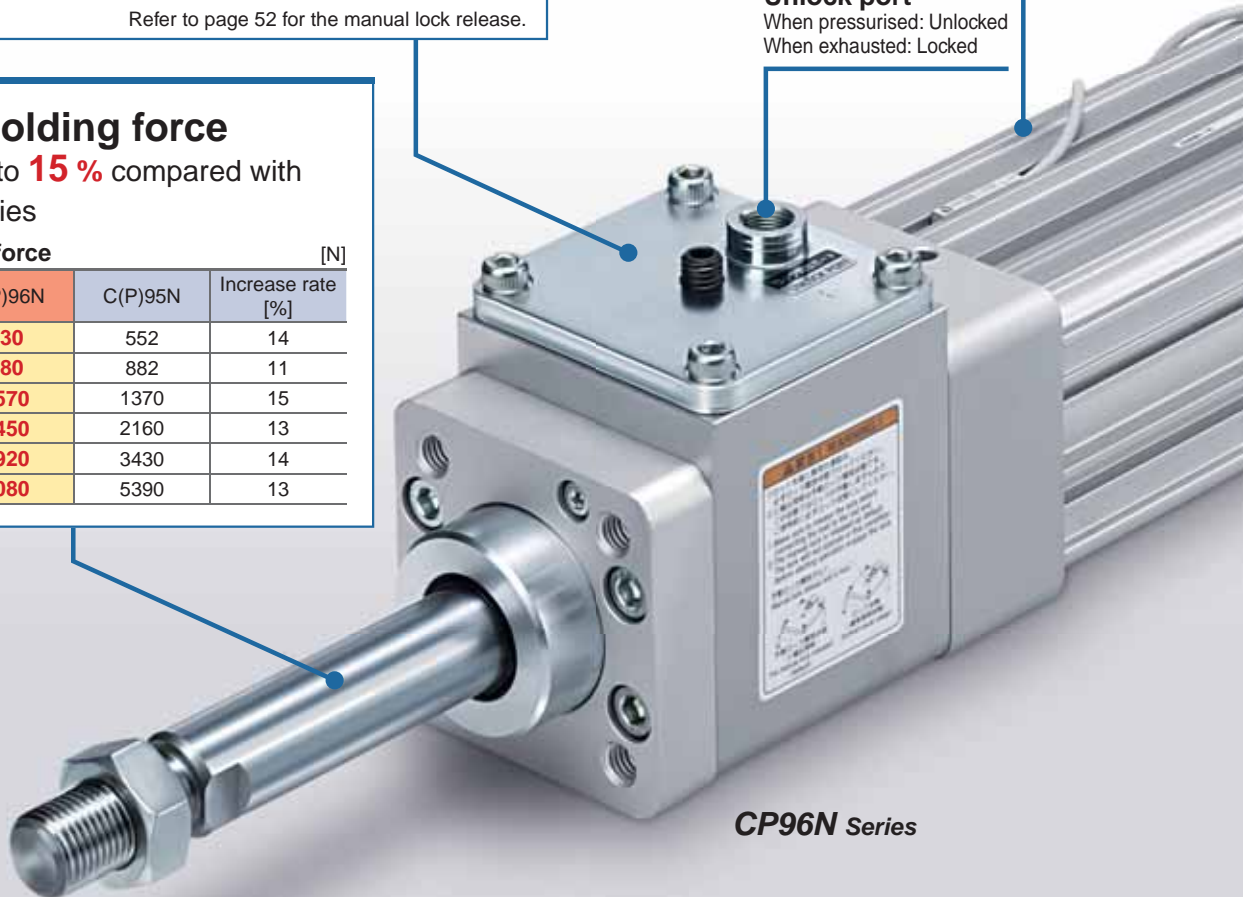

CP96N Series

emergency stops, and drop prevention

Compact auto switches are mountable.

- Solid state auto switch: D-M9□
- Reed auto switch: D-A9□
- Magnetic field-resistant auto switch: D-P3DWA, D-P4DW

* Only applicable to the C96N



The lock unit and the cylinder are separable in order to improve maintainability.



Refer to pages 52 and 53 for the replacement procedure.

Air cushion + Bumper cushion Combined structure

- The cushion stroke time can now be reduced with the double cushioning, which improves the cycle time.
- The bumper cushion reduces the metal noise that occurs when the piston stops at the end of the stroke.



C96N Series

Part numbers for products with a rod end bracket and/or a pivot bracket are available.

It is not necessary to order a bracket for the applicable cylinder separately.

* Rod end brackets and pivot brackets are shipped together with the product but do not come assembled.

Example) CP96ND **D** 40-100C- **N** **W** -M9BW

• Mounting

Pivot bracket

—	No bracket
N	Pivot bracket

* Applicable only to D (Double clevis) and T (Centre trunnion) mounting types
* T (Centre trunnion) is only applicable to the C96N.

Double clevis

Centre trunnion



Rod end bracket

—	No bracket
W	Rod clevis

With rod end bracket
W: Rod clevis





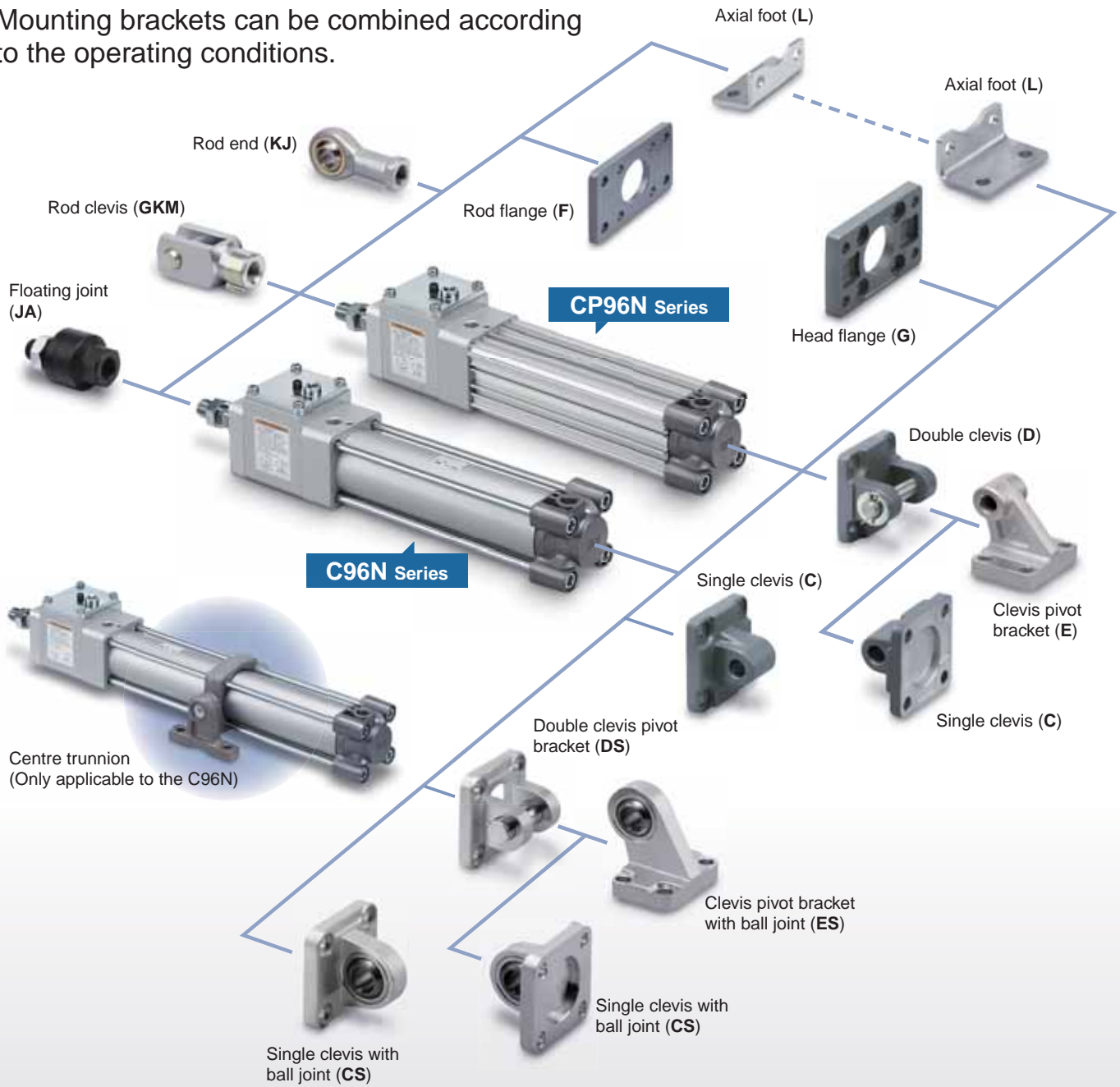

Various mounting bracket options

Mounting brackets can be combined according to the operating conditions.



Series Variations

Type	Action	Bore size [mm]						Page
		32	40	50	63	80	100	
Standard CP96N Series	 Double acting, Single rod	●	●	●	●	●	●	9
	 Double acting, Double rod	●	●	●	●	●	●	
Standard C96N Series	 Double acting, Single rod	●	●	●	●	●	●	25
	 Double acting, Double rod	●	●	●	●	●	●	

Lock Unit

A safety mechanism can be designed if required. It can also be combined with a wide variety of actuators.

- Prevents the workpiece from falling
- Retains the workpiece position even when the air supply is shut off due to power failure, etc.



Lock unit model	MWB□32-UT	MWB□40-UT	MWB□50-UT	MWB□63-UT	MWB□80-UT	MWB□100-UT
Applicable rod size [mm]*1	Ø 12 f8	Ø 16 f8	Ø 20 f8	Ø 20 f8	Ø 25 f8	Ø 30 f8
Bore size of combinable cylinder [mm]	Ø 32	Ø 40	Ø 50	Ø 63	Ø 80	Ø 100
Lock holding force*2 (Max. static load) [N]	630	980	1,570	2,450	3,920	6,080
Made to order common specifications	With coil scraper (-XC35), Made of stainless steel (-XC68)					

*1 The applicable rod size affects the holding force, so use a rod with the rod size tolerance shown in the table above.

*2 The holding force (max. static load) shows the maximum capability and does not show the normal holding capability. Be sure to select a cylinder using the method described in Model Selection (page 6).

Part numbers for lock units with an applicable rod are now available.

It is not necessary to order a rod for the lock unit separately.

* Rod is shipped together with the product.

Example) **MWB** **B** **40** - **UT** - **500**

Lock unit

Rod length

* Refer to page 43 for details on rod lengths.

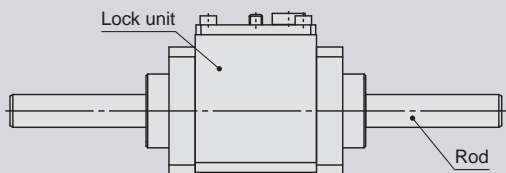

Application Example

Example of combination with a rodless cylinder

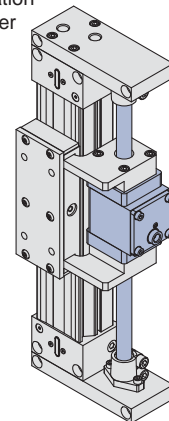

CONTENTS

Cylinder with Lock *CP96N/C96N Series*

CP96N Series

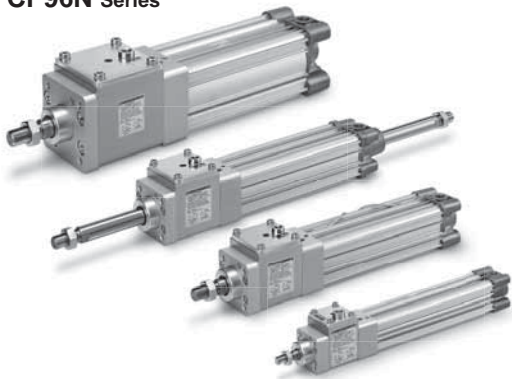

C96N Series

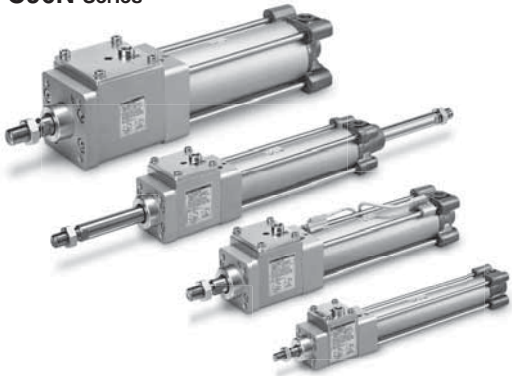

MWB-UT Series

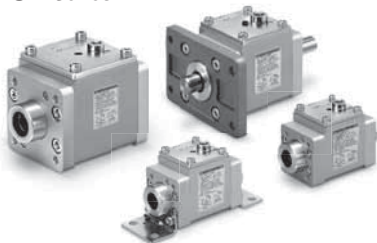

Model Selection	p. 6
Working Principle	p. 8

● CP96N Series/Double Acting, Single Rod/Double Rod

How to Order	p. 9
Specifications	p. 10
Construction (Single Rod)	p. 12
Dimensions (Single Rod)	p. 13
Construction (Double Rod)	p. 16
Dimensions (Double Rod)	p. 17
Auto Switch Mounting	p. 23

● Accessories

p. 19

● Prior to Use

Auto Switch Connections and Examples	p. 24
--	-------

● C96N Series/Double Acting, Single Rod/Double Rod

How to Order	p. 25
Specifications	p. 26
Construction (Single Rod)	p. 28
Dimensions (Single Rod)	p. 29
Construction (Double Rod)	p. 33
Dimensions (Double Rod)	p. 34
Auto Switch Mounting	p. 36

● MWB-UT Series/Lock Unit

How to Order	p. 43
Specifications	p. 43
Construction	p. 44
Dimensions	p. 45

● Simple Specials

Change of Rod End Shape (-XA0 to XA30)

● Made to Order Common Specifications

With Coil Scraper (-XC35)

Made of Stainless Steel (For Lock Unit, With Hard Chrome Plating)(-XC68)

● Specific Product Precautions

p. 49

Safety Instructions	Back cover
---------------------------	------------

CP96N/C96N Series Model Selection

Precautions on Model Selection

⚠ Caution

1. In order that the originally selected maximum speed shall not be exceeded, be certain to use a speed controller to adjust the total movement distance of the load so that movement takes place in no less than the applicable movement time. The movement time is the time that is necessary for the load to travel the total movement distance from the start without any intermediate stops.
2. In cases where the cylinder stroke and the movement distance of the load are different (double speed mechanism etc.), use the movement distance of the load for selection purposes.

Example)

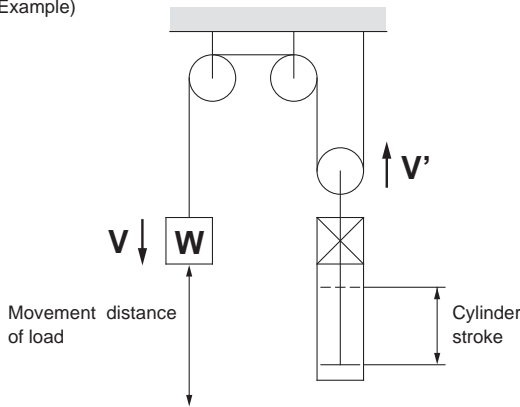

3. The following selection example and procedures are based on use at the intermediate stop (including emergency stops during operation). However, when the cylinder is in a locked state, kinetic energy does not act upon it. Under these conditions, use the load mass at the maximum speed (V) of 100 mm/s shown in graphs 5 to 7 on page 7 depending on the operating pressure and select models.

Selection Example

- Load mass : $m = 50 \text{ kg}$
- Movement distance : $st = 500 \text{ mm}$
- Movement time : $t = 2 \text{ s}$
- Load condition : Vertical downward = Load in direction of rod extension
- Operating pressure : $P = 0.4 \text{ MPa}$

Step 1: From graph 1, find the maximum movement speed of the load
 \therefore Maximum speed : $V \approx 350 \text{ mm/s}$.

Step 2: Select graph 6 (Refer to page 7.) based upon the load conditions and operating pressure, and then from the intersection of the maximum speed $V = 350 \text{ mm/s}$ found in Step 1, and the load mass $m = 50 \text{ kg}$.
 $\therefore \text{ } \varnothing 63 \rightarrow$ Select a C(P)96N63 or larger bore size.

Step 1 Find the maximum load speed V .

Find the maximum load speed: V [mm/s] from the load movement time: t [s] and the movement distance: st [mm].

Graph 1

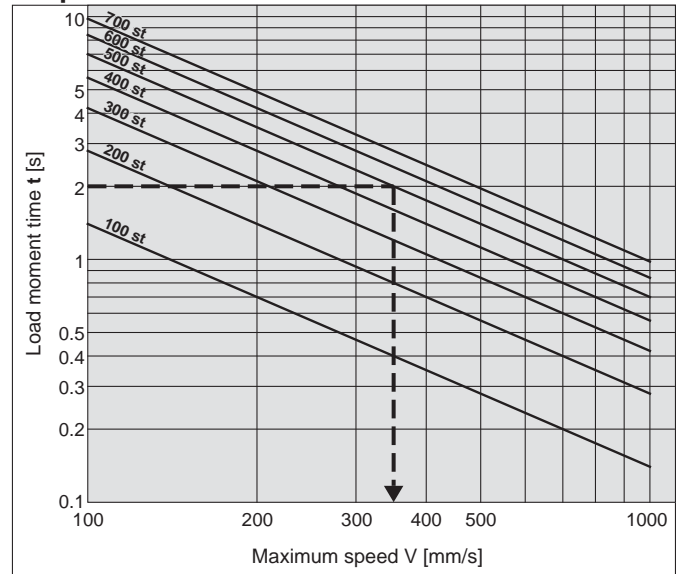

Step 2 Find the bore size.

Select a graph based upon the load condition and operating pressure, and then find the point of intersection for the maximum speed found in Step 1 and the load mass. Select the bore size on the above the point of intersection.

Load Condition

Operating Pressure

Load in the direction at the right angle to rod

(* Being held by a guide)

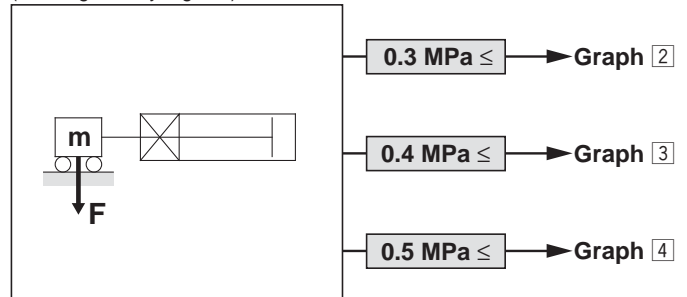

Load in the direction of rod extension Load in the direction of rod retraction

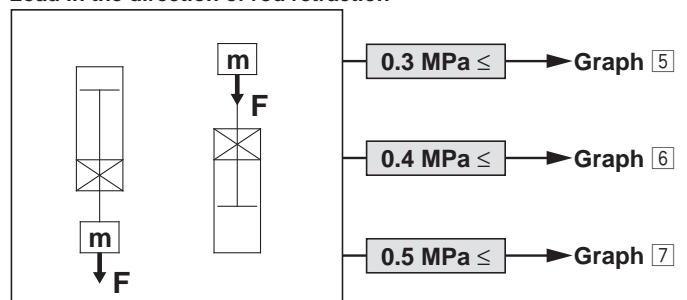

Model Selection

Working Principle

CP96N

Double Acting, Single Rod

Double Acting, Double Rod

C96N

Double Acting, Single Rod

Double Acting, Double Rod

Lock Unit MWB-UT

Accessories

Auto Switch

Made to Order

Specific Product Precautions

CP96N/C96N Series

Selection Graph

Graph 2

$0.3 \text{ MPa} \leq P < 0.4 \text{ MPa}$

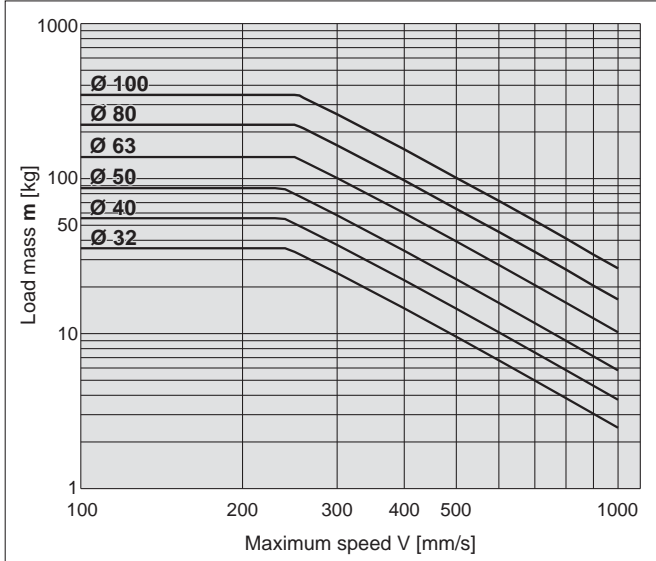

Graph 5

$0.3 \text{ MPa} \leq P < 0.4 \text{ MPa}$

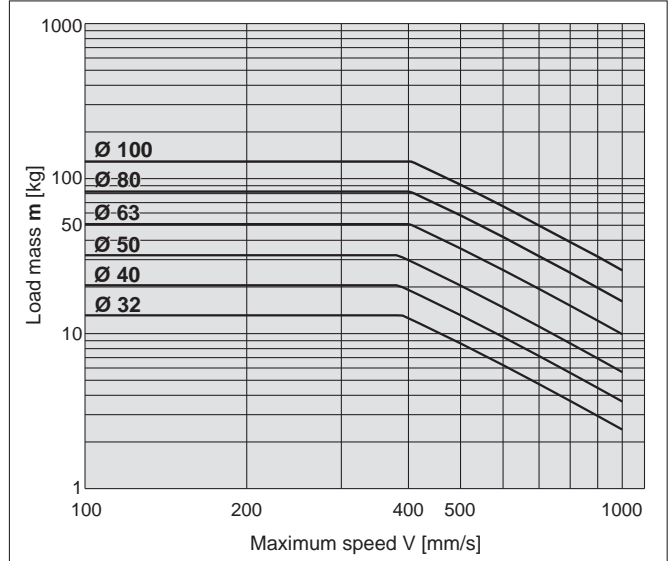

Graph 3

$0.4 \text{ MPa} \leq P < 0.5 \text{ MPa}$

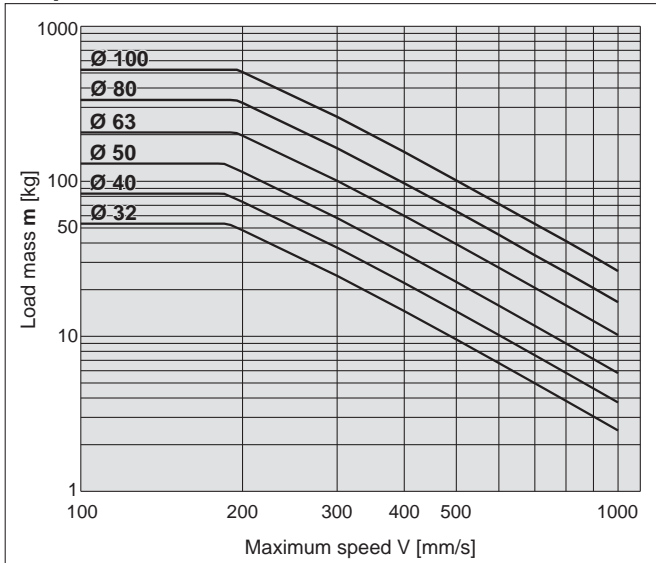

Graph 6

$0.4 \text{ MPa} \leq P < 0.5 \text{ MPa}$

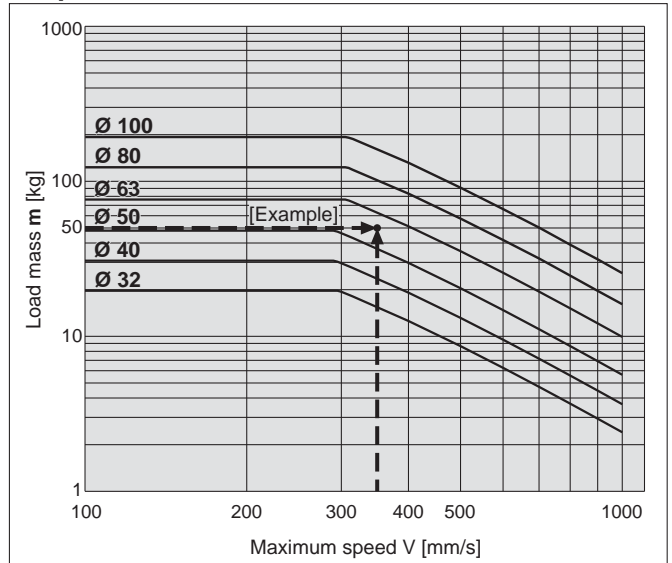

Graph 4

$0.5 \text{ MPa} \leq P$

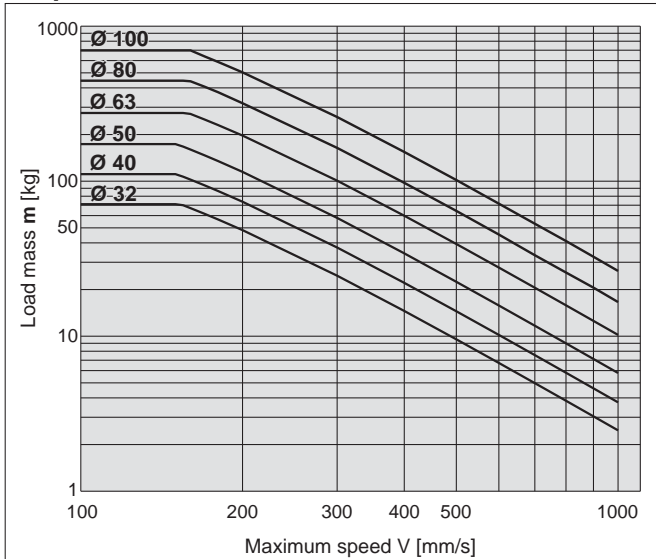

Graph 7

$0.5 \text{ MPa} \leq P$

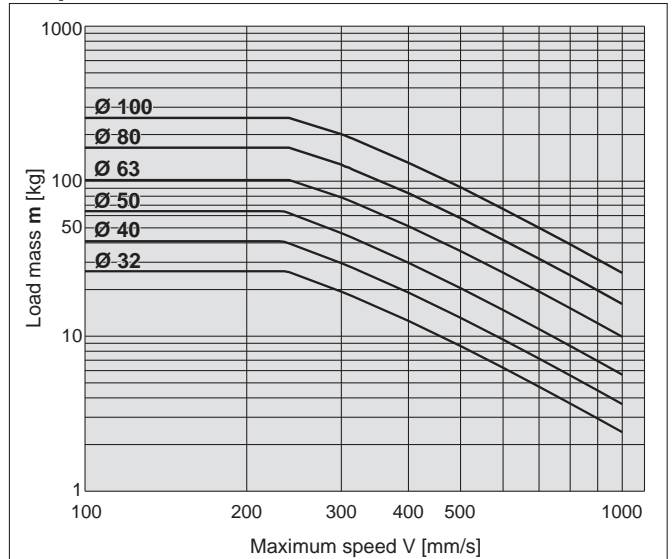

CP96N/C96N Series Working Principle

Normal Operation (Operation pressurised by air)

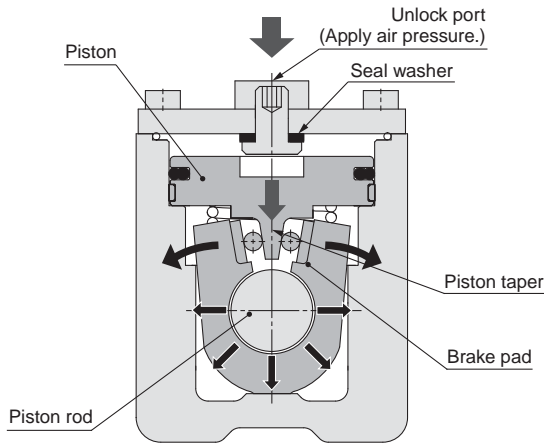

Unlocked (when air pressure is applied)

When air is supplied to the unlock port, the piston moves downward, the brake pad is opened by the tapered portion at the bottom of the piston and the piston rod will be free to move. This is the lock released state.

* Check that there is no air leakage from the unlock port.

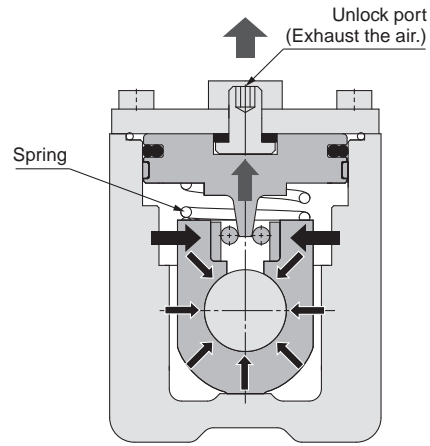

Locked (when air is exhausted)

When the air supplied to the unlock port is exhausted, the piston moves upward due to the spring force at the bottom of the piston and rigidity of the brake pad. Then, the brake pad is closed and holds the piston rod, locking its movement. This is the locked state.

Manual Lock Release

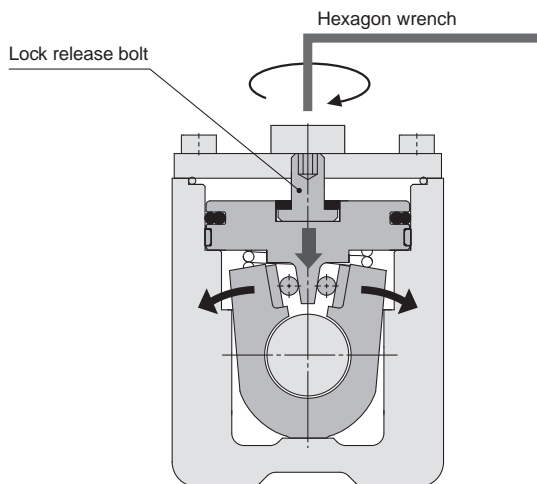

Manual lock released

When the lock release bolt is screwed-in, the piston moves downward, the brake pad is opened by the tapered portion of the piston and the piston rod will be freed. This holds the lock in the released state. Refer to page 52 for how to return to the locked state.

Model Selection

Working Principle

CP96N

Double Acting, Single Rod

Double Acting, Double Rod

C96N

Double Acting, Single Rod

Double Acting, Double Rod

Lock Unit
MWB-UT

Accessories

Auto Switch

Made to Order

Specific Product Precautions

Cylinder with Lock

Double Acting, Single Rod/Double Rod

CP96N Series

∅ 32, ∅ 40, ∅ 50, ∅ 63, ∅ 80, ∅ 100 RoHS

How to Order

CP96N **B** **32** - **100** **C** **J** **W** - [] - [] - []

With auto switch **CP96N D** **B** **32** - **100** **C** **J** **W** - [] - [] - **M9BW** **S** - []

With auto switch (Built-in magnet)

Mounting

Symbol	Description	Single rod	Double rod
B	Basic	○	○
L	Axial foot	○	○
F	Rod flange	○	○
G	Head flange	○	○
C	Single clevis	○	—
D	Double clevis	○	—

* Mounting brackets are shipped together with the product but do not come assembled.
* The single clevis with ball joint should be ordered separately.

Bore size

	32	40	50	63	80	100
	32 mm	40 mm	50 mm	63 mm	80 mm	100 mm

Cylinder stroke [mm]
Refer to page 1 0 for standard strokes.

Air cushion on both ends + Bumper cushion

Rod boot

	Without rod boot
J	Nylon tarpaulin (One end)
JJ	Nylon tarpaulin (Both ends)
K	Heat-resistant tarpaulin (One end)
KK	Heat-resistant tarpaulin (Both ends)

Rod

	Single rod	Double rod
—	Single rod	Double rod
W	Double rod	

Pivot bracket

	No bracket	Pivot bracket
—	No bracket	Pivot bracket
N	Pivot bracket	

* Only for the D mounting type
* The double clevis pivot bracket and clevis pivot bracket with ball joint should be ordered separately.

Rod end bracket

	No bracket	Rod clevis
—	No bracket	Rod clevis
W	Rod clevis	

* The floating joint and rod end should be ordered separately.

Made to order
Refer to page 10 for details.

Number of auto switches

	2	1	3	n
—	2	1	3	n
S	1			
3	3			
n	n			

Auto switch

	Without auto switch
—	Without auto switch

* For applicable auto switches, refer to the table below.

Refer to the Ordering Example of Cylinder Assembly on page 10.

Applicable Auto Switches/Refer to the Web Catalogue for further information on auto switches.

Type	Special function	Electrical entry	Indicator light	Wiring (Output)	Load voltage		Auto switch model		Lead wire length [m]				Pre-wired connector	Applicable load		
					DC	AC	Perpendicular	In-line	0.5 (—)	1 (M)	3 (L)	5 (Z)		IC circuit	Relay, PLC	
Solid state auto switch	—	Grommet	No	3-wire (NPN)	24 V	5 V, 12 V	—	M9NV	M9N	●	●	●	○	○	IC circuit	Relay, PLC
				3-wire (PNP)				M9PV	M9P	●	●	●	○	○		
				2-wire				M9BV	M9B	●	●	●	○	○		
				2-wire				M9BV	M9B	●	●	●	○	○		
	Diagnostic indication (2-colour indicator)	Grommet	Yes	3-wire (NPN)	24 V	5 V, 12 V	—	M9NWV	M9NW	●	●	●	○	○	IC circuit	
				3-wire (PNP)				M9PWV	M9PW	●	●	●	○	○		
				2-wire				M9BWV	M9BW	●	●	●	○	○		
				2-wire				M9BWV	M9BW	●	●	●	○	○		
Water-resistant (2-colour indicator)	Grommet	No	3-wire (NPN)	24 V	5 V, 12 V	—	M9NAV*1	M9NA*1	○	○	●	○	○	IC circuit		
			3-wire (PNP)				M9PAV*1	M9PA*1	○	○	●	○	○			
			2-wire				M9BAV*1	M9BA*1	○	○	●	○	○			
			2-wire				M9BAV*1	M9BA*1	○	○	●	○	○			
Reed auto switch	—	Grommet	Yes	3-wire (NPN equivalent)	24 V	12 V	100 V or less	A96V	A96	●	—	●	—	—	IC circuit	—
				2-wire				A93V*2	A93	●	●	●	●	—	—	
				2-wire				A90V	A90	●	—	●	—	—	—	

*1 Water-resistant type auto switches can be mounted on the above models, but SMC cannot guarantee water resistance.

*2 The 1 m lead wire is only applicable to the D-A93.

* Lead wire length symbols: 0.5 m — (Example) M9NV
1 m M (Example) M9NWM
3 m L (Example) M9NWL
5 m Z (Example) M9NWZ

* Solid state auto switches marked with "○" are produced upon receipt of order.

* Since there are applicable auto switches other than those listed above, refer to page 23 for details.

* The D-A9□/M9□/M9□W/M9□A auto switches are shipped together with the product but do not come assembled. (Only the auto switch mounting brackets are assembled before shipment.)

* The D-Y59A, Y69A, Y7P, Y7□W, Z7□, Z80 cannot be mounted.

Moreover, the D-M9□□ and A9□ auto switches cannot be mounted on square groove.

Cylinder with Lock Double Acting, Single Rod/Double Rod **CP96N Series**

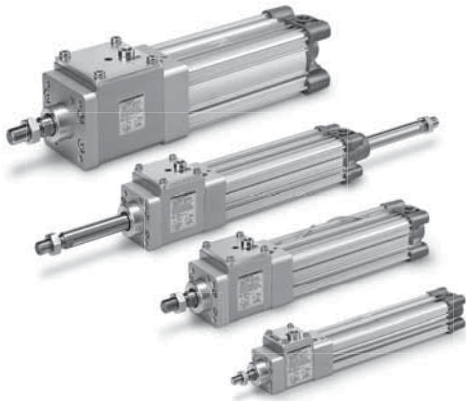

Cylinder Specifications

Bore size [mm]	32	40	50	63	80	100
Action	Double acting					
Fluid	Air					
Proof pressure	1.5 MPa					
Max. operating pressure	1.0 MPa					
Min. operating pressure	0.08 MPa					
Ambient and fluid temperatures	Without auto switch: -10 °C to 70 °C With auto switch: -10 °C to 60 °C (No freezing)					
Lubricant	Not required (Non-lube)					
Piston speed	50 to 1000 mm/s*1					
Stroke length tolerance	Up to 500 st: $^{+2.0}_0$, 501 to 1000 st: $^{+2.4}_0$, 1001 to 1500 st: $^{+2.8}_0$, 1501 to 2000 st: $^{+3.2}_0$					
Cushion	Air cushion on both ends + Bumper cushion					
Port size	G1/8	G1/4	G3/8		G1/2	
Mounting	Basic, Axial foot, Rod flange, Head flange Single clevis, Double clevis					

*1 Load limits exist depending upon the piston speed when locked, mounting direction, and operating pressure.



Made to Order Common Specifications
(For details, refer to pages 46 to 48.)

Symbol	Specifications
-XA□	Change of rod end shape (Single rod only)
-XC35	With coil scraper

For details of **cylinders with auto switches**
⇒ page 23

- Auto Switch Proper Mounting Position (Detection at stroke end)
- Minimum Stroke for Auto Switch Mounting
- Operating Range

Ordering Example of Cylinder Assembly

Cylinder model: CP96NDD50-100C-NW-M9BW

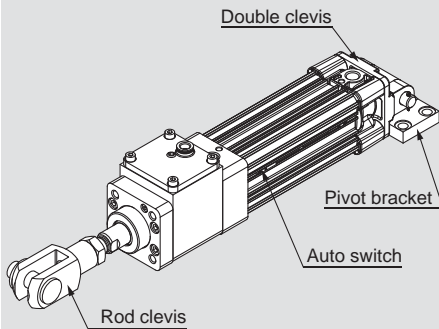

Mounting D: Double clevis
Pivot bracket N: Yes
Rod end bracket W: Rod clevis
Auto switch D-M9BW: 2 pcs.

* Pivot bracket, rod clevis, and auto switch are shipped together with the product but do not come assembled.

Lock Unit Specifications

Bore size [mm]	32	40	50	63	80	100
Locking action	Exhaust locking					
Max. operating pressure	1.0 MPa					
Min. operating pressure	0.3 MPa					
Locking direction	Both directions					
Holding force (Max. static load) [N]*1	630	980	1570	2450	3920	6080

*1 The holding force (max. static load) shows the maximum capability and does not show the normal holding capability. Be sure to select a cylinder using the method described in Model Selection (page 6).

Standard Strokes

* When using with auto switches, refer to the Minimum Stroke for Auto Switch Mounting table on page 23.

Bore size	Standard stroke	Max. stroke
32	25, 50, 80, 100, 125, 160, 200, 250, 320, 400, 500	2000
40	25, 50, 80, 100, 125, 160, 200, 250, 320, 400, 500	2000
50	25, 50, 80, 100, 125, 160, 200, 250, 320, 400, 500, 600	2000
63	25, 50, 80, 100, 125, 160, 200, 250, 320, 400, 500, 600	2000
80	25, 50, 80, 100, 125, 160, 200, 250, 320, 400, 500, 600, 700, 800	2000
100	25, 50, 80, 100, 125, 160, 200, 250, 320, 400, 500, 600, 700, 800	2000

- * The manufacturing of intermediate strokes is possible. (Spacers are not used.)
- * Applicable strokes should be confirmed according to the usage. For details, refer to the Air Cylinders Model Selection in the **Web Catalogue**. In addition, products that exceed the standard stroke might not be able to fulfill the specifications due to deflection, etc.
- * When using a rod boot, a stroke range of up to 1000 mm is available. Please consult with SMC when exceeding a 1000 mm stroke.

Stopping Accuracy

Bore size [mm]	32	40	50	63	80	100
Lock type	Exhaust locking					
Stopping accuracy [mm]	±1.0					
Conditions	<ul style="list-style-type: none"> · Mounting orientation: Horizontal · Supply pressure: 0.5 MPa · Piston speed: 300 mm/s · Load condition: Upper limit of allowed value Solenoid valve for locking is mounted on the unlock port. Maximum value of stopping position dispersion from 100 measurements					

Model Selection
 Working Principle
 CP96N
 Double Acting, Single Rod
 Double Acting, Double Rod
 C96N
 Double Acting, Single Rod
 Double Acting, Double Rod
 Lock Unit MWB-UT
 Accessories
 Auto Switch
 Made to Order
 Specific Product Precautions

CP96N Series

Accessories

Mounting		Basic	Axial foot	Rod flange	Head flange	Single clevis	Double clevis
Standard	Rod end nut	●	●	●	●	●	●
	Clevis pin	—	—	—	—	—	●
Option	Rod end	●	●	●	●	●	●
	Rod clevis	●	●	●	●	●	●
	Rod boot	●	●	●	●	●	●

- * Do not use a rod end (or floating joint) together with a single clevis with a ball joint (or clevis pivot bracket with a ball joint).
- * Refer to pages 19 to 22 for dimensions and part numbers of the accessories. (Excludes the rod end nut, clevis pin, and rod boot)

Mounting Bracket/Rod End Bracket Part Nos.

Bore size [mm]		32	40	50	63	80	100
L	Axial foot*1	L5032	L5040	L5050	L5063	L5080	L5100
F, G	Rod/Head flange	F5032	F5040	F5050	F5063	F5080	F5100
C	Single clevis	C5032	C5040	C5050	C5063	C5080	C5100
D	Double clevis	D5032	D5040	D5050	D5063	D5080	D5100
E	Clevis pivot bracket	E5032	E5040	E5050	E5063	E5080	E5100
CS	Single clevis with ball joint	CS5032	CS5040	CS5050	CS5063	CS5080	CS5100
DS	Double clevis pivot bracket for ES accessory	DS5032	DS5040	DS5050	DS5063	DS5080	DS5100
ES	Clevis pivot bracket with ball joint	ES5032	ES5040	ES5050	ES5063	ES5080	ES5100
GKM	Rod clevis	GKM10-20	GKM12-24	GKM16-32	GKM16-32	GKM20-40	GKM20-40
KJ	Rod end	KJ10D	KJ12D	KJ16D	KJ16D	KJ20D	KJ20D
JA	Floating joint	JA30-10-125	JA40-12-125	JA50-16-150	JA50-16-150	JAH50-20-150	JAH50-20-150

- *1 Order two foot brackets per cylinder.
- * Accessories for each mounting bracket are as follows.
Axial foot, Rod/Head flange, Single clevis: Body mounting bolt
Double clevis (D, DS): Body mounting bolt, Clevis pin, Clevis pin bracket
- * The rod clevis (GKM) is compliant with ISO 8140.
- * The rod end (KJ) is compliant with ISO 8139.

Theoretical Output



[Unit: N]

Bore size [mm]	Rod size [mm]	Operating direction	Piston area [mm ²]	Operating pressure [MPa]								
				0.2	0.3	0.4	0.5	0.6	0.7	0.8	0.9	1.0
32	12	OUT	804	161	241	322	402	482	563	643	724	804
		IN	691	138	207	276	346	415	484	553	622	691
40	16	OUT	1257	251	377	503	629	754	880	1006	1131	1257
		IN	1056	211	317	422	528	634	739	845	950	1056
50	20	OUT	1963	393	589	785	982	1178	1374	1570	1767	1963
		IN	1649	330	495	660	825	989	1154	1319	1484	1649
63	20	OUT	3117	623	935	1247	1559	1870	2182	2494	2805	3117
		IN	2803	561	841	1121	1402	1682	1962	2242	2523	2803
80	25	OUT	5027	1005	1508	2011	2514	3016	3519	4022	4524	5027
		IN	4536	907	1361	1814	2268	2722	3175	3629	4082	4536
100	30	OUT	7854	1571	2356	3142	3927	4712	5498	6283	7069	7854
		IN	7147	1429	2144	2859	3574	4288	5003	5718	6432	7147

* Theoretical output [N] = Pressure [MPa] x Piston area [mm²]

Weight

Single Rod (Ø 32 to Ø 100)

[kg]

Bore size [mm]		32	40	50	63	80	100
Basic weight (at 0 stroke)	Basic						
	Lock unit	0.42	0.83	1.15	1.79	2.81	5.44
	Cylinder (at 0 stroke)	0.55	0.84	1.41	1.79	3.25	4.61
		Total	0.97	1.67	2.56	3.58	6.06
Mounting bracket weight (including bracket mounting bolts)	Foot bracket (2 pcs.)	0.16	0.20	0.38	0.46	0.89	1.09
	Rod/Head flange	0.20	0.23	0.47	0.58	1.30	1.81
	Single clevis bracket	0.16	0.23	0.37	0.60	1.07	1.73
	Double clevis bracket	0.20	0.32	0.45	0.71	1.28	2.11
Additional weight per 50 mm of stroke		0.14	0.18	0.30	0.32	0.49	0.54
Accessories	Rod end	0.07	0.11	0.22	0.40		
	Rod clevis	0.09	0.15	0.34	0.69		

Rod Boot Material

Symbol	Material	Max. ambient temp.
J	Nylon tarpaulin	70 °C
K	Heat-resistant tarpaulin	110 °C*1

*1 Max. ambient temperature for rod boot itself

Allowable Kinetic Energy of the Cylinder*1

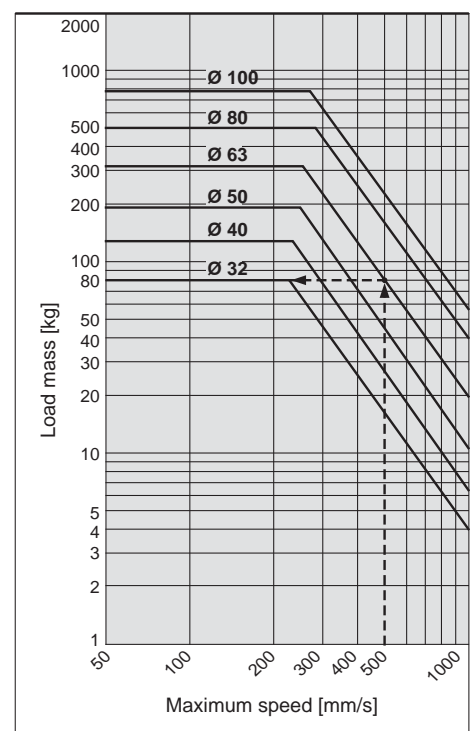

Example) Load limit at rod end when the air cylinder Ø 63 is actuated at 500 mm/s.
Extend upward from 500 mm/s on the horizontal axis of the graph to the intersection point with the line for a tube bore size of 63 mm, and then extend leftward from this point to find the load of 80 kg.

*1 The allowable kinetic energy of the cylinder is shown without the intermediate stop or emergency stop. Refer to page 6 or 7 for the kinetic energy with intermediate or emergency stop.

Calculation example)

CP96NL32-100C (Axial foot, Ø 32, 100 mm stroke)

- Basic weight...0.42 (Lock unit, Ø 32)
- Basic weight...0.55 (Cylinder, Ø 32)
- Additional weight...0.14/50 mm stroke
- Cylinder stroke...100 mm stroke
- Foot bracket...0.16

$$0.42 + 0.55 + (0.14/50) \times 100 + 0.16 = 1.41 \text{ kg}$$

Construction (Single Rod)

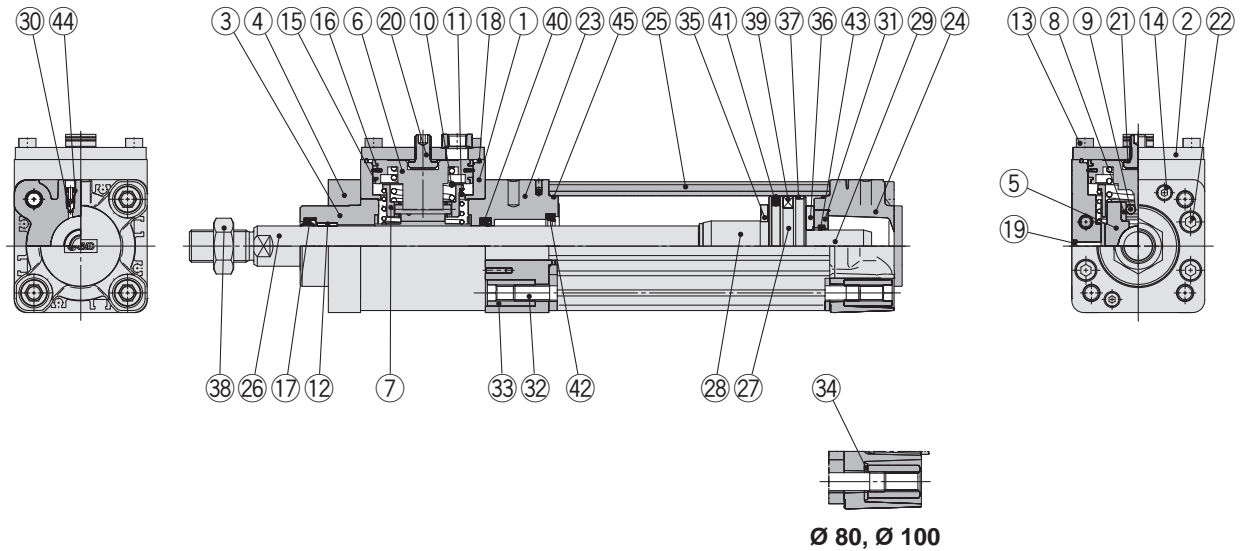

Component Parts

No.	Description	Material	Qty.	Note
1	Brake unit	Aluminium alloy	1	Hard anodised
2	Cap	Rolled steel	1	Zinc chromated
3	Collar	Aluminium alloy	1	Chromated
4	Retaining plate	Aluminium alloy	1	Anodised
5	Brake pad	Cast iron	1	
6	Piston A	Aluminium alloy	1	
7	Roller holder	Carbon steel	1	
8	Roller receiver	Stainless steel	2	
9	Needle roller	Carbon steel	2	
10	Piston spring	Spring steel	1	Zinc chromated
11	Roller spring	Spring steel	1	Zinc chromated
12	Bushing	Bearing alloy	1	
13	Hexagon socket head cap screw	Alloy steel	4	
14	Hexagon socket head cap screw	Alloy steel	2	
15	Wear ring A	Resin	2	
16	Piston seal A	NBR	1	
17	Rod seal A	NBR	1	
18	Gasket	NBR	1	
19	Element	Bronze	1	
20	Release bolt	Alloy steel	1	
21	Seal washer	NBR + Stainless steel	1	
22	Hexagon socket head cap screw	Alloy steel	4	
23	Rod cover	Aluminium alloy	1	Anodised
24	Head cover	Aluminium die-cast	1	Chromated
25	Cylinder tube	Aluminium alloy	1	Hard anodised
26	Piston rod	Carbon steel	1	Hard chrome plating
27	Piston B	Aluminium alloy	1	Ø 32 to Ø 63
		Aluminium die-cast	1	Ø 80, Ø 100
28	Cushion ring	Aluminium alloy	1	Anodised
29	Cushion ring B	Aluminium alloy	1	Anodised
30	Cushion valve	Resin	2	
31	Cushion seal holder	Aluminium alloy	1	Anodised

Component Parts

No.	Description	Material	Qty.	Note
32	Tie-rod	Carbon steel	4	Zinc chromated
33	Tie-rod nut	Rolled steel	8	Zinc chromated
34	Flat washer	Steel	8	Ø 80, Ø 100
35	Bumper A	Urethane	1	
36	Bumper B	Urethane	1	
37	Wear ring B	Resin	1	
38	Rod end nut	Carbon steel	1	Zinc chromated
39	Magnet	—	(1)	
40	Rod seal B	NBR	1	
41	Piston seal B	NBR	1	
42	Cushion seal A	Urethane	1	
43	Cushion seal B	Urethane	1	
44	Cushion valve seal	NBR	2	
45	Cylinder tube gasket	NBR	2	

Replacement Parts/Seal Kit

Bore size [mm]	Kit no.	Contents
32	C96N32-PS	A set of 17 Rod seal A, 40 Rod seal B, 41 Piston seal B, 42 Cushion seal A, 43 Cushion seal B, and 45 Cylinder tube gasket
40	C96N40-PS	
50	C96N50-PS	
63	C96N63-PS	
80	C96N80-PS	
100	C96N100-PS	

* Never disassemble the lock unit. It should be replaced as a unit. Refer to page 52 for the part numbers for placing an order. The seal kit shown above contains the rod seal for the cylinder and lock unit. Order the seal kit suitable for the cylinder bore size.

* The seal kit shown above includes a grease pack.
(Ø 32, Ø 40, Ø 50: 10 g, Ø 63, Ø 80: 20 g, Ø 100: 30 g)
Order with the following part number when only the grease pack is needed.
Grease pack part number: GR-S-010 (10 g), GR-S-020 (20 g)

CP96N Series

Dimensions (Single Rod)

Basic: CP96NB

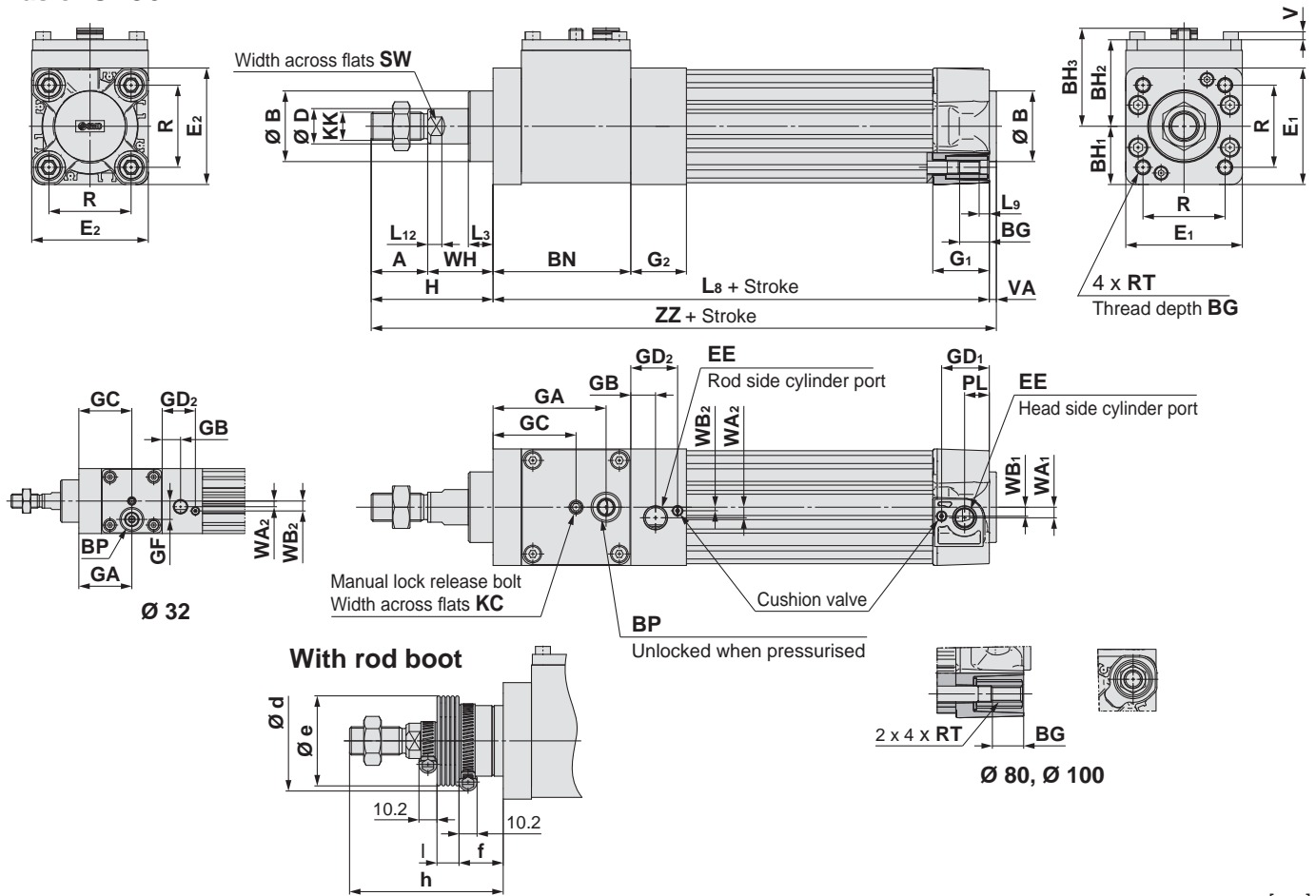

Bore size	Stroke range	A	Ø B _{d11}	BG	BH ₁	BH ₂	BH ₃	BN	BP	Ø D	E ₁	E ₂	EE	G ₁	G ₂	GA	GB	GC	GD ₁	GD ₂	GF
32	Up to 2000	22	30	16	23	38.5	46.5	59	G1/8	12	46	47	G1/8	28.9	28.5	37.5	13	37.5	23.9	23.5	13
40	Up to 2000	24	35	16	28.5	42.5	48.5	73	G1/8	16	57	54	G1/4	32.6	29	59.5	14	44.5	27.6	24	—
50	Up to 2000	32	40	16	33	49	55.5	78	G1/8	20	66	66	G1/4	32	31.5	64	14	47	27	26.5	—
63	Up to 2000	32	45	16	39	52.5	59.5	90	G1/4	20	78	77	G3/8	38.6	31.5	73	16	53	31.6	26.5	—
80	Up to 2000	40	45	17	49	64.5	71.5	113	G1/4	25	98	99	G3/8	38.4	38	92	16	65	32	31.6	—
100	Up to 2000	40	55	17	58	73.5	80.5	131	G1/4	30	116	118	G1/2	42.9	38	109	18	74	36.5	31.6	—

Bore size	Stroke range	H	KC	KK	L ₃	L ₈	L ₉	L ₁₂	PL	R	RT	SW	V	VA	WA ₁	WA ₂	WB ₁	WB ₂	WH	ZZ
32	Up to 2000	48	3	M10 x 1.25	13	152	4	6	13	32.5	M6 x 1	10	3.5	4	4	4	7	7	26	204
40	Up to 2000	54	3	M12 x 1.25	13	171	4	6.5	14	38	M6 x 1	13	4.5	4	5	7	8.9	1.8	30	229
50	Up to 2000	69	4	M16 x 1.5	14	181	5	8	14	46.5	M8 x 1.25	17	4.5	4	6	6	5.1	2	37	254
63	Up to 2000	69	4	M16 x 1.5	14	200.5	5	8	16	56.5	M8 x 1.25	17	5.5	4	9	9	6.3	2	37	273.5
80	Up to 2000	86	5	M20 x 1.5	20	238	—	10	16	72	M10 x 1.5	22	7.5	4	11.5	11.5	6	6	46	328
100	Up to 2000	91	5	M20 x 1.5	20	261.5	—	10	18	89	M10 x 1.5	26	9.5	4	17	17	10	3	51	356.5

With Rod Boot

Bore size	d	e	f	h												
				1 to 50	51 to 100	101 to 150	151 to 200	201 to 300	301 to 400	401 to 500	501 to 600	601 to 700	701 to 800	801 to 900	901 to 1000	
32	54	36	23	75	88	100	113	138	163	188	213	238	263	288	313	
40	56	41	23	75	88	100	113	138	163	188	213	238	263	288	313	
50	64	51	25	87	100	112	125	150	175	200	225	250	275	300	325	
63	64	51	25	87	100	112	125	150	175	200	225	250	275	300	325	
80	68	56	29	103	116	128	141	166	191	216	241	266	291	316	341	
100	76	61	29	103	116	128	141	166	191	216	241	266	291	316	341	

Bore size	l												
	1 to 50	51 to 100	101 to 150	151 to 200	201 to 300	301 to 400	401 to 500	501 to 600	601 to 700	701 to 800	801 to 900	901 to 1000	
32	12.5	25	37.5	50	75	100	125	150	175	200	225	250	
40	12.5	25	37.5	50	75	100	125	150	175	200	225	250	
50	12.5	25	37.5	50	75	100	125	150	175	200	225	250	
63	12.5	25	37.5	50	75	100	125	150	175	200	225	250	
80	12.5	25	37.5	50	75	100	125	150	175	200	225	250	
100	12.5	25	37.5	50	75	100	125	150	175	200	225	250	

Dimensions: With Mounting Bracket

* Refer to Basic (B) for other dimensions.

Axial foot: CP96NL

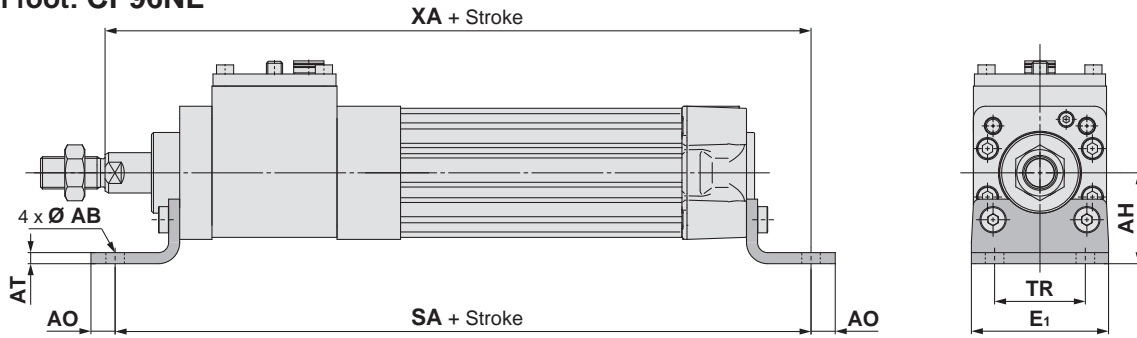

[mm]								
Bore size	AB	AH	AO	AT	E ₁	SA	TR	XA
32	7	32	10	4.5	48	200	32	202
40	10	36	11	4.5	55	227	36	229
50	10	45	12	5.5	68	245	45	250
63	10	50	12	5.5	80	264.5	50	269.5
80	12	63	14	6.5	100	320	63	325
100	14.5	71	16	6.5	120	343.5	75	353.5

Flange

Rod side: CP96NF

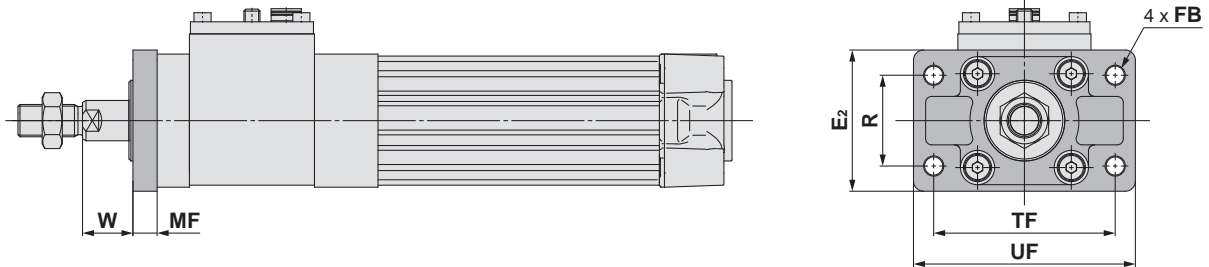

Head side: CP96NG

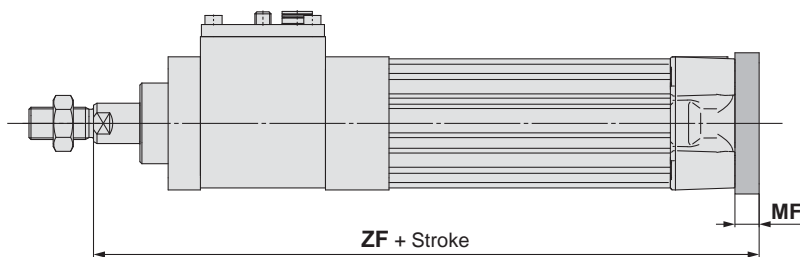

[mm]								
Bore size	E ₂	FB	MF	R	TF	UF	W	ZF
32	50	7	10	32	64	79	16	188
40	55	9	10	36	72	90	20	211
50	70	9	12	45	90	110	25	230
63	80	9	12	50	100	120	25	249.5
80	100	12	16	63	126	153	30	300
100	120	14	16	75	150	178	35	328.5

Model Selection

Working Principle

CP96N

Double Acting, Single Rod

Double Acting, Double Rod

C96N

Double Acting, Single Rod

Double Acting, Double Rod

Lock Unit
MWB-UT

Accessories

Auto Switch

Made to Order

Specific Product Precautions

CP96N Series

Dimensions: With Mounting Bracket

* Refer to Basic (B) for other dimensions.

Single clevis: CP96NC

Double clevis: CP96ND

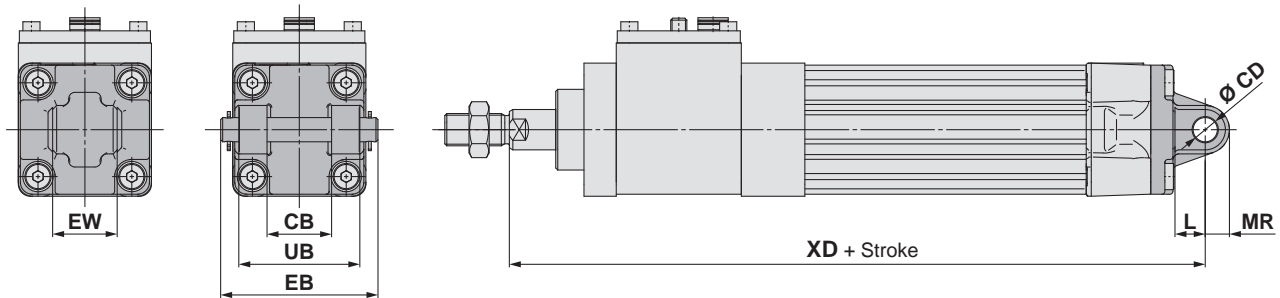

Single clevis Double clevis

Bore size	CB _{H14}	CD _{H9}	EB	EW	L	MR	UB _{h14}	XD
32	26	10	65	26 ^{-0.2} _{-0.6}	12	9.5	45	200
40	28	12	75	28 ^{-0.2} _{-0.6}	15	12	52	226
50	32	12	80	32 ^{-0.2} _{-0.6}	15	12	60	245
63	40	16	90	40 ^{-0.2} _{-0.6}	20	16	70	269.5
80	50	16	110	50 ^{-0.2} _{-0.6}	20	16	90	320
100	60	20	140	60 ^{-0.2} _{-0.6}	25	20	110	353.5

Pivot Bracket: Double Clevis Pivot Bracket

Double clevis pivot bracket

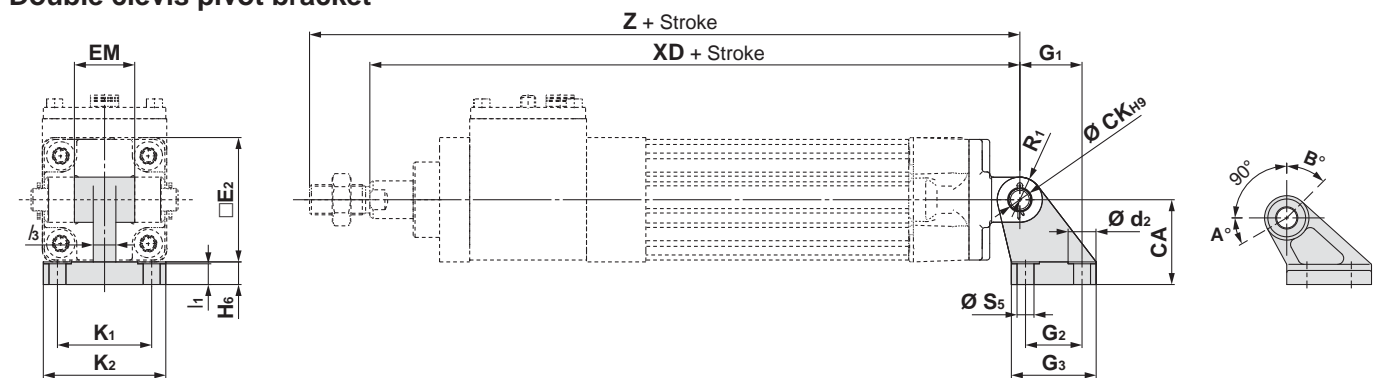

Bore size	Part no.	CA	Ø CK	Ø d ₂	□E ₂	EM	G ₁	G ₂	G ₃ (Max.)	H ₆	K ₁	K ₂ (Max.)	l ₁	l ₃ (Max.)	R ₁	Ø S ₅	XD	Z
32	E5032	32	10	11	47	26 ^{-0.2} _{-0.6}	21	18	31	8	38	51	7	10	10	6.6	200	222
40	E5040	36	12	11	54	28 ^{-0.2} _{-0.6}	24	22	35	10	41	54	9	10	11	6.6	226	250
50	E5050	45	12	15	66	32 ^{-0.2} _{-0.6}	33	30	45	12	50	65	11	12	12	9	245	277
63	E5063	50	16	15	77	40 ^{-0.2} _{-0.6}	37	35	50	12	52	67	11	14	15	9	269.5	301.5
80	E5080	63	16	18	99	50 ^{-0.2} _{-0.6}	47	40	60	14	66	86	12.5	18	15	11	320	360
100	E5100	71	20	18	118	60 ^{-0.2} _{-0.6}	55	50	70	15	76	96	13.5	20	19	11	353.5	393.5

Rotating Angle

Bore size [mm]	A°	B°	A° + B° + 90°
32, 40	25°	45°	160°
50, 63	40°	60°	190°
80, 100	30°	55°	175°

Construction (Double Rod)

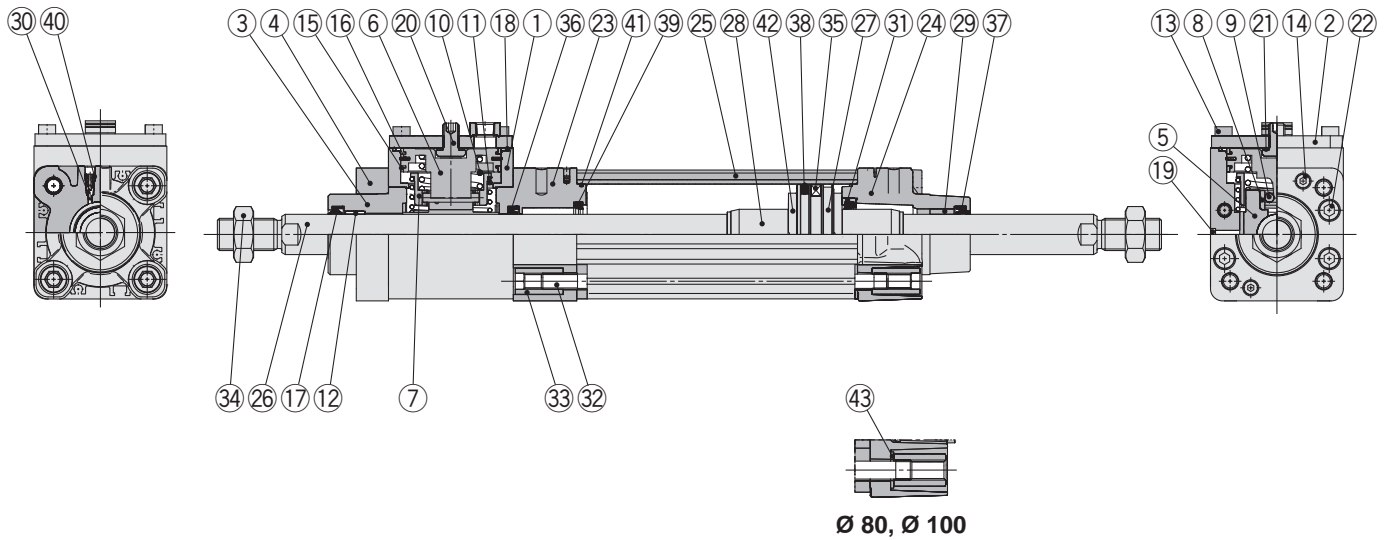

Component Parts

No.	Description	Material	Qty.	Note
1	Brake unit	Aluminium alloy	1	Hard anodised
2	Cap	Rolled steel	1	Zinc chromated
3	Collar	Aluminium alloy	1	Chromated
4	Retaining plate	Aluminium alloy	1	Anodised
5	Brake pad	Cast iron	1	
6	Piston A	Aluminium alloy	1	
7	Roller holder	Carbon steel	1	
8	Roller receiver	Stainless steel	2	
9	Needle roller	Carbon steel	2	
10	Piston spring	Spring steel	1	Zinc chromated
11	Roller spring	Spring steel	1	Zinc chromated
12	Bushing A	Bearing alloy	1	
13	Hexagon socket head cap screw	Alloy steel	4	
14	Hexagon socket head cap screw	Alloy steel	2	
15	Wear ring	Resin	2	
16	Piston seal A	NBR	1	
17	Rod seal A	NBR	1	
18	Gasket	NBR	1	
19	Element	Bronze	1	
20	Release bolt	Alloy steel	1	
21	Seal washer	NBR + Stainless steel	1	
22	Hexagon socket head cap screw	Alloy steel	4	
23	Rod cover A	Aluminium alloy	1	Anodised
24	Rod cover B	Aluminium die-cast	1	Zinc chromated
25	Cylinder tube	Aluminium alloy	1	Hard anodised
26	Piston rod	Carbon steel	1	Hard chrome plating
27	Piston B	Aluminium alloy	1	
28	Cushion ring	Aluminium alloy	2	Anodised
29	Bushing B	Bearing alloy	1	
30	Cushion valve	Resin	2	

Component Parts

No.	Description	Material	Qty.	Note
31	Cushion seal holder	Aluminium alloy	1	Anodised
32	Tie-rod	Carbon steel	4	Zinc chromated
33	Tie-rod nut	Rolled steel	8	Zinc chromated
34	Rod end nut	Carbon steel	2	Zinc chromated
35	Magnet	—	(1)	
36	Rod seal B	NBR	1	
37	Rod seal C	NBR	1	
38	Piston seal B	NBR	1	
39	Cushion seal	Urethane	2	
40	Cushion valve seal	NBR	2	
41	Cylinder tube gasket	NBR	2	
42	Bumper	Urethane	2	
43	Flat washer	Steel	8	Ø 80, Ø 100

Replacement Parts/Seal Kit

Bore size [mm]	Kit no.	Contents
32	C96N32W-PS	A set of 17 Rod seal A, 36 Rod seal B, 37 Rod seal C, 38 Piston seal B, 39 Cushion seal, and 41 Cylinder tube gasket
40	C96N40W-PS	
50	C96N50W-PS	
63	C96N63W-PS	
80	C96N80W-PS	
100	C96N100W-PS	

* Never disassemble the lock unit. It should be replaced as a unit. Refer to page 52 for the part numbers for placing an order. The seal kit shown above contains the rod seal for the cylinder and lock unit. Order the seal kit suitable for the cylinder bore size.

* The seal kit shown above includes a grease pack.
(Ø 32, Ø 40, Ø 50: 10 g, Ø 63, Ø 80: 20 g, Ø 100: 30 g)
Order with the following part number when only the grease pack is needed.
Grease pack part number: GR-S-010 (10 g), GR-S-020 (20 g)

CP96N Series

Dimensions (Double Rod)

Basic: CP96NB-W

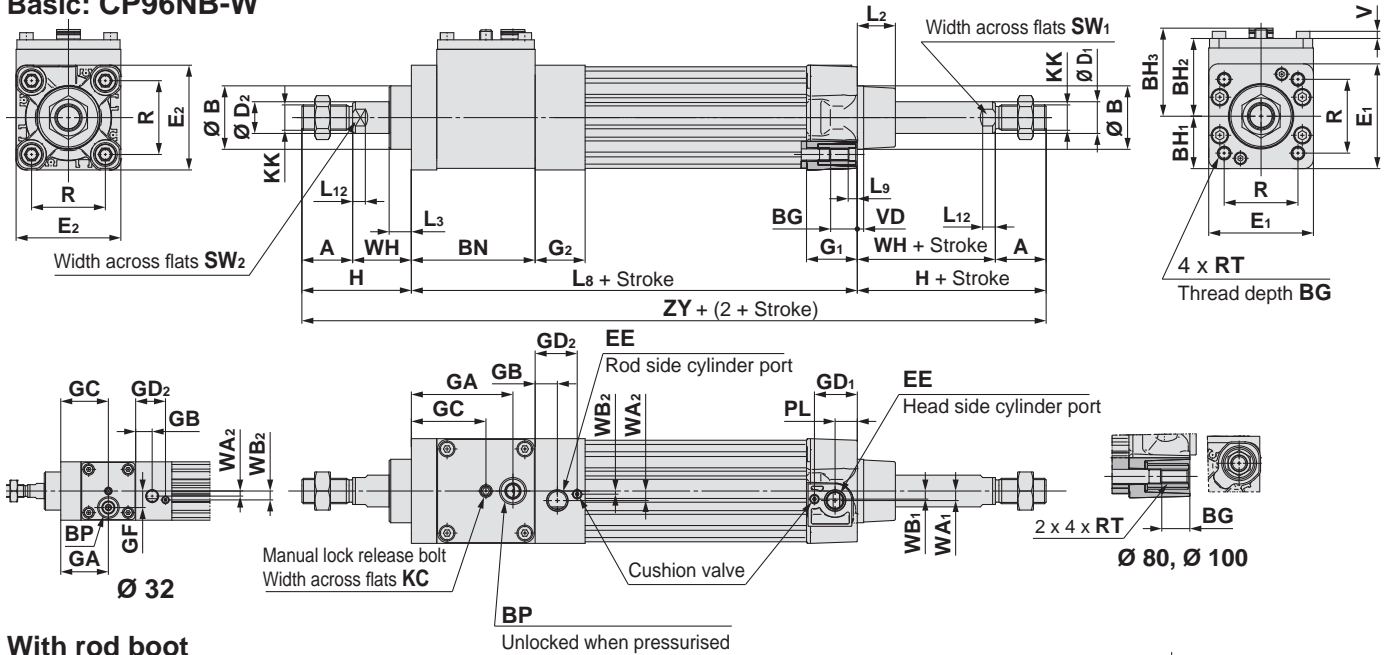

With rod boot

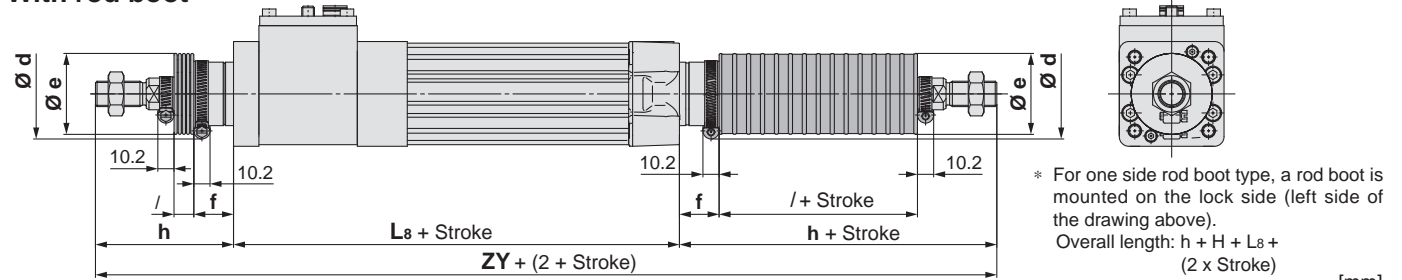

Bore size	Stroke range	A	Ø B _{d11}	BG	BH ₁	BH ₂	BH ₃	BN	BP	Ø D ₁	Ø D ₂	E ₁	E ₂	EE	G ₁	G ₂	GA	GB	GC	GD ₁	GD ₂	GF	H
32	Up to 1000	22	30	16	23	38.5	46.5	59	G1/8	12	12	46	47	G1/8	28.9	28.5	37.5	13	37.5	23.9	23.5	13	48
40	Up to 1000	24	35	16	28.5	42.5	48.5	73	G1/8	16	16	57	54	G1/4	32.6	29	59.5	14	44.5	27.6	24	—	54
50	Up to 1000	32	40	16	33	49	55.5	78	G1/8	20	20	66	66	G1/4	32	31.5	64	14	47	27	26.5	—	69
63	Up to 1000	32	45	16	39	52.5	59.5	90	G1/4	20	20	78	77	G3/8	38.6	31.5	73	16	53	31.6	26.5	—	69
80	Up to 1000	40	45	17	49	64.5	71.5	113	G1/4	25	25	98	99	G3/8	38.4	38	92	16	65	32	31.6	—	86
100	Up to 1000	40	55	17	58	73.5	80.5	131	G1/4	25	30	116	118	G1/2	42.9	38	109	18	74	36.5	31.6	—	91

Bore size	Stroke range	KC	KK	L ₂	L ₃	L ₈	L ₉	L ₁₂	PL	R	RT	SW ₁	SW ₂	V	VD	WA ₁	WA ₂	WB ₁	WB ₂	WH	ZY
32	Up to 1000	3	M10 x 1.25	15	13	152	4	6	13	32.5	M6 x 1	10	10	3.5	4	4	4	7	7	26	248
40	Up to 1000	3	M12 x 1.25	17	13	171	4	6.5	14	38	M6 x 1	13	13	4.5	4	5	7	8.9	1.8	30	279
50	Up to 1000	4	M16 x 1.5	24	14	181	5	8	14	46.5	M8 x 1.25	17	17	4.5	4	6	6	5.1	2	37	319
63	Up to 1000	4	M16 x 1.5	24	14	200.5	5	8	16	56.5	M8 x 1.25	17	17	5.5	4	9	9	6.3	2	37	338.5
80	Up to 1000	5	M20 x 1.5	30	20	238	—	10	16	72	M10 x 1.5	22	22	7.5	4	11.5	11.5	6	6	46	410
100	Up to 1000	5	M20 x 1.5	32	20	261.5	—	10	18	89	M10 x 1.5	22	26	9.5	4	17	17	10	3	51	443.5

With Rod Boot

Bore size	d	e	f	h																			
				1 to 50	51 to 100	101 to 150	151 to 200	201 to 300	301 to 400	401 to 500	501 to 600	601 to 700	701 to 800	801 to 900	901 to 1000								
32	54	36	23	75	88	100	113	138	163	188	213	238	263	288	313								
40	Lock unit side	56	41	23	75	88	100	113	138	163	188	213	238	263	288	313							
	Opposite side of the lock unit	54	36	23	75	88	100	113	138	163	188	213	238	263	288	313							
50	64	51	25	87	100	112	125	150	175	200	225	250	275	300	325								
63	64	51	25	87	100	112	125	150	175	200	225	250	275	300	325								
80	68	56	29	103	116	128	141	166	191	216	241	266	291	316	341								
100	Lock unit side	76	61	29	103	116	128	141	166	191	216	241	266	291	316	341							
	Opposite side of the lock unit	68	56	29	103	116	128	141	166	191	216	241	266	291	316	341							

Bore size	I																ZY															
	1 to 50	51 to 100	101 to 150	151 to 200	201 to 300	301 to 400	401 to 500	501 to 600	601 to 700	701 to 800	801 to 900	901 to 1000	1 to 50	51 to 100	101 to 150	151 to 200	201 to 300	301 to 400	401 to 500	501 to 600	601 to 700	701 to 800	801 to 900	901 to 1000								
32	12.5	25	37.5	50	75	100	125	150	175	200	225	250	302	328	352	378	428	478	528	578	628	678	728	778								
40	12.5	25	37.5	50	75	100	125	150	175	200	225	250	321	347	371	397	447	497	547	597	647	697	747	797								
50	12.5	25	37.5	50	75	100	125	150	175	200	225	250	355	381	405	431	481	531	581	631	681	731	781	831								
63	12.5	25	37.5	50	75	100	125	150	175	200	225	250	374.5	400.5	424.5	450.5	500.5	550.5	600.5	650.5	700.5	750.5	800.5	850.5								
80	12.5	25	37.5	50	75	100	125	150	175	200	225	250	444	470	494	520	570	620	670	720	770	820	870	920								
100	12.5	25	37.5	50	75	100	125	150	175	200	225	250	467.5	493.5	517.5	543.5	593.5	643.5	693.5	743.5	793.5	843.5	893.5	943.5								

Dimensions: With Mounting Bracket

* Refer to Basic (B) for other dimensions.

Axial foot: CP96NL-W

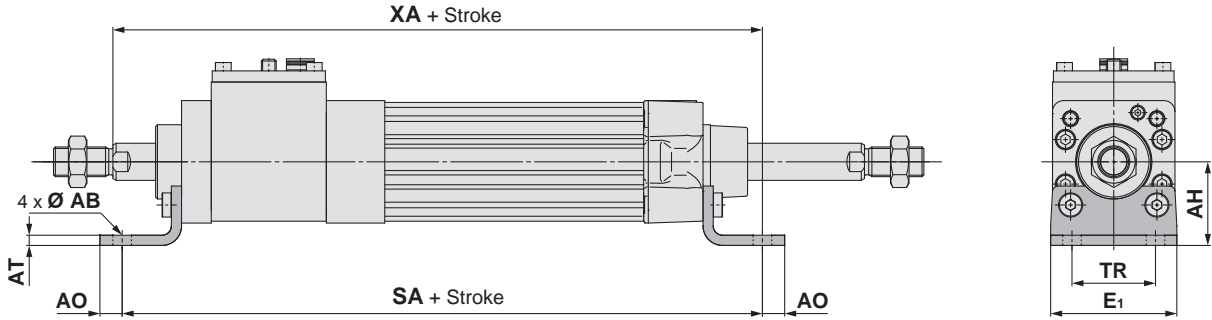

Bore size	AB	AH	AO	AT	E ₁	SA	TR	XA
32	7	32	10	4.5	48	200	32	202
40	10	36	11	4.5	55	227	36	229
50	10	45	12	5.5	68	245	45	250
63	10	50	12	5.5	80	264.5	50	269.5
80	12	63	14	6.5	100	320	63	325
100	14.5	71	16	6.5	120	343.5	75	353.5

Flange

Rod side: CP96NF-W

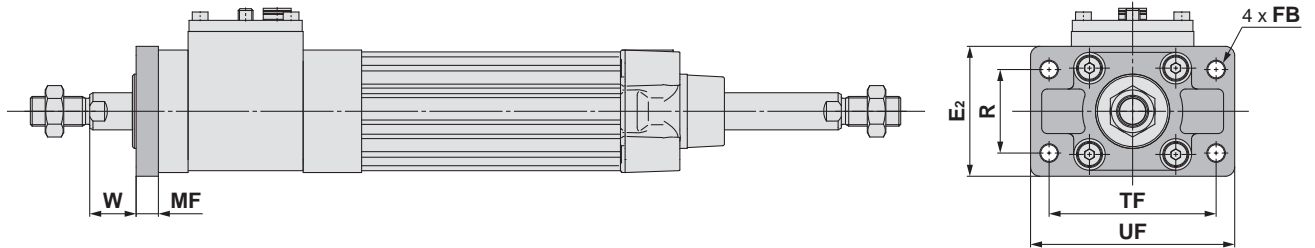

Head side: CP96NG-W

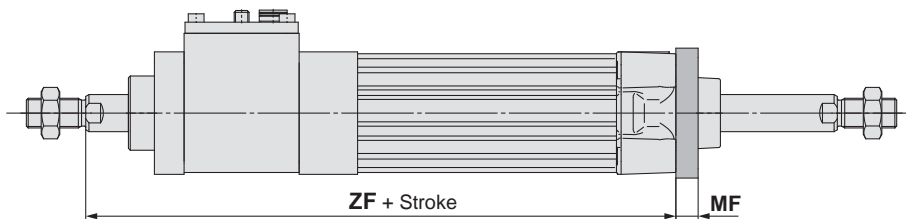

Bore size	E ₂	FB	MF	R	TF	UF	W	ZF
32	50	7	10	32	64	79	16	188
40	55	9	10	36	72	90	20	211
50	70	9	12	45	90	110	25	230
63	80	9	12	50	100	120	25	249.5
80	100	12	16	63	126	153	30	300
100	120	14	16	75	150	178	35	328.5

Model Selection

Working Principle

CP96N

Double Acting, Single Rod

Double Acting, Double Rod

C96N

Double Acting, Single Rod

Double Acting, Double Rod

Lock Unit
MWB-UT

Accessories

Auto Switch

Made to Order

Specific Product Precautions

CP96N/C96N Series Accessories

Dimensions: Mounting Brackets

Axial foot (L)

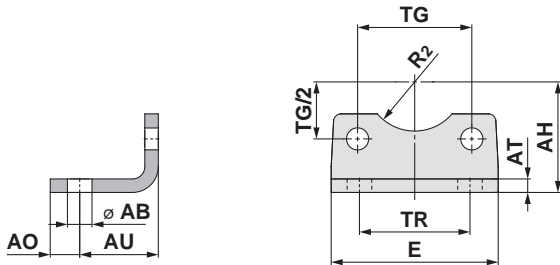

[mm]

Bore size	Part no.	AB	AH	AO	AT	AU	E	R ₂	TG _{±0.2}	TR	Screw size
32	L5032	7	32	10	4.5	24	48	15	32.5	32	M6 x 16L
40	L5040	10	36	11	4.5	28	55	17.5	38	36	M6 x 16L
50	L5050	10	45	12	5.5	32	68	20	46.5	45	M8 x 20L
63	L5063	10	50	12	5.5	32	80	22.5	56.5	50	M8 x 20L
80	L5080	12	63	14	6.5	41	100	22.5	72	63	M10 x 20L
100	L5100	14.5	71	16	6.5	41	120	27.5	89	75	M10 x 20L

* Supplied with 4 mounting screws

Flange (F, G)

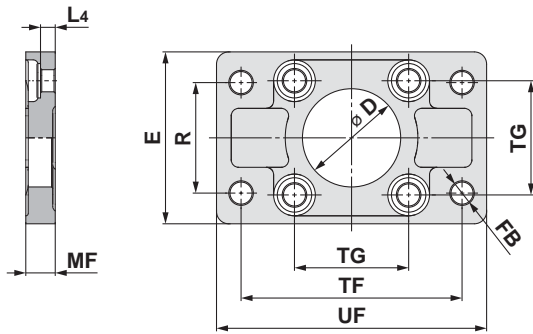

[mm]

Bore size	Part no.	D _{H11}	E	∅ _{FB}	L ₄	MF	R	TF	TG _{±0.2}	UF	Screw size
32	F5032	30	50	7	5	10	32	64	32.5	79	M6 x 20L
40	F5040	35	55	9	5	10	36	72	38	90	M6 x 20L
50	F5050	40	70	9	6.5	12	45	90	46.5	110	M8 x 20L
63	F5063	45	80	9	6.5	12	50	100	56.5	120	M8 x 20L
80	F5080	45	100	12	9	16	63	126	72	153	M10 x 25L
100	F5100	55	120	14	9	16	75	150	89	178	M10 x 25L

* Supplied with 4 mounting screws

Single clevis (C)

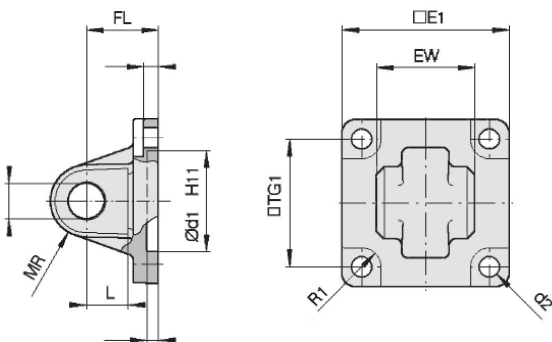

[mm]

Bore size	Part no.	∅ _{CD}	∅ _{d1}	∅ _{d2}	E ₁	EW	FL	L	l ₁	l ₂	MR	R ₁	TG ₁
32	C5032	10	30	6.6	45	26 ^{-0.2} _{-0.6}	22	12	5	5.5	9.5	6.5	32.5
40	C5040	12	35	6.6	51	28 ^{-0.2} _{-0.6}	25	15	5	5.5	12	6.5	38
50	C5050	12	40	9	64	32 ^{-0.2} _{-0.6}	27	15	5	6.5	12	8.5	46.5
63	C5063	16	45	9	74	40 ^{-0.2} _{-0.6}	32	20	5	6.5	16	8.5	56.5
80	C5080	16	45	11	94	50 ^{-0.2} _{-0.6}	36	20	5	10	16	11	72
100	C5100	20	55	11	113	60 ^{-0.2} _{-0.6}	41	25	5	10	20	12	89

* Supplied with 4 mounting screws

Dimensions: Mounting Brackets, Pivot Brackets for Cylinder Mounting

Double clevis (D)

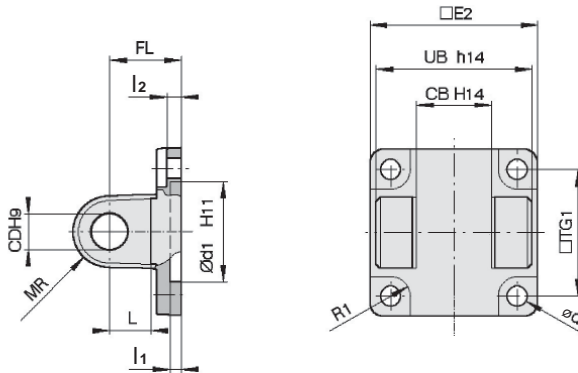

Bore size	Part no.	CB	Ø CD	Ø d1	Ø d2	E2	FL	L	l1	l2	MR	R1	TG1	UB
32	D5032	26	10	30	6.6	48	22	12	5	5.5	9.5	6.5	32.5	45
40	D5040	28	12	35	6.6	56	25	15	5	5.5	12	6.5	38	52
50	D5050	32	12	40	9	64	27	15	5	6.5	12	8.5	46.5	60
63	D5063	40	16	45	9	75	32	20	5	6.5	16	8.5	56.5	70
80	D5080	50	16	45	11	95	36	20	5	10	16	11	72	90
100	D5100	60	20	55	11	115	41	25	5	10	20	12	89	110

* Supplied with 4 mounting screws, clevis pin, and clevis pin bracket

Clevis pivot bracket (E)

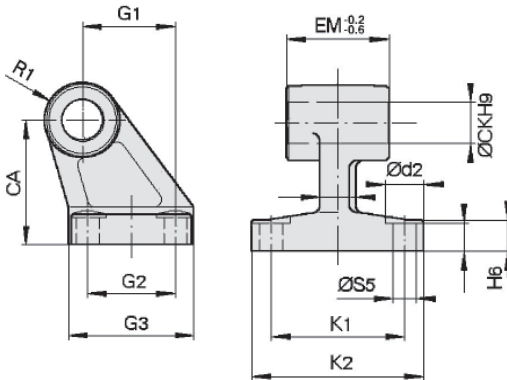

Bore size	Part no.	CA	Ø CK	Ø d2	EM	G1	G2	G3 (Max.)	H6	K1	K2 (Max.)	l1	l3 (Max.)	R1	Ø S5
32	E5032	32	10	11	26 ^{-0.2} / _{-0.6}	21	18	31	8	38	51	7	10	10	6.6
40	E5040	36	12	11	28 ^{-0.2} / _{-0.6}	24	22	35	10	41	54	9	10	11	6.6
50	E5050	45	12	15	32 ^{-0.2} / _{-0.6}	33	30	45	12	50	65	11	12	12	9
63	E5063	50	16	15	40 ^{-0.2} / _{-0.6}	37	35	50	12	52	67	11	14	15	9
80	E5080	63	16	18	50 ^{-0.2} / _{-0.6}	47	40	60	14	66	86	12.5	18	15	11
100	E5100	71	20	18	60 ^{-0.2} / _{-0.6}	55	50	70	15	76	96	13.5	20	19	11

Single clevis with ball joint (CS)

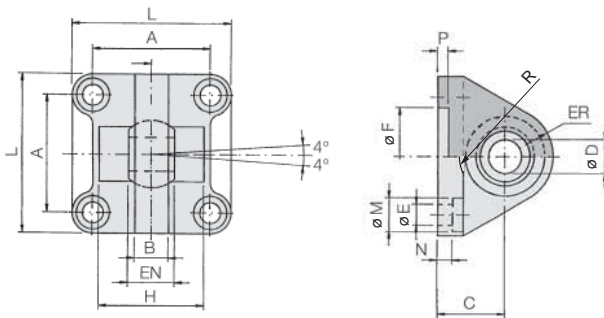

Bore size	Part no.	A	B (Max.)	C	Ø DH7	Ø E	EN ⁰ / _{-0.1}	ER (Max.)	Ø FH11	H ±0.5	L	Ø M	N	P
32	CS5032	32.5	10.5	22	10	6.6	14	15	30	—	45	10.5	5.5	5
40	CS5040	38	12	25	12	6.6	16	18	35	—	55	11	5.5	5
50	CS5050	46.5	15	27	16	9	21	20	40	51	65	15	6.5	5
63	CS5063	56.5	15	32	16	9	21	23	45	—	75	15	6.5	5
80	CS5080	72	18	36	20	11	25	27	45	70	95	18	10	5
100	CS5100	89	18	41	20	11	25	30	55	—	115	18	10	5

* Supplied with 4 mounting screws

Model Selection

Working Principle

CP96N

Double Acting, Single Rod

Double Acting, Double Rod

C96N

Double Acting, Single Rod

Double Acting, Double Rod

Lock Unit MWB-UT

Accessories

Auto Switch

Made to Order

Specific Product Precautions

CP96N/C96N Series

Dimensions: Pivot Brackets for Cylinder Mounting

Double clevis pivot bracket (DS) for ES accessory

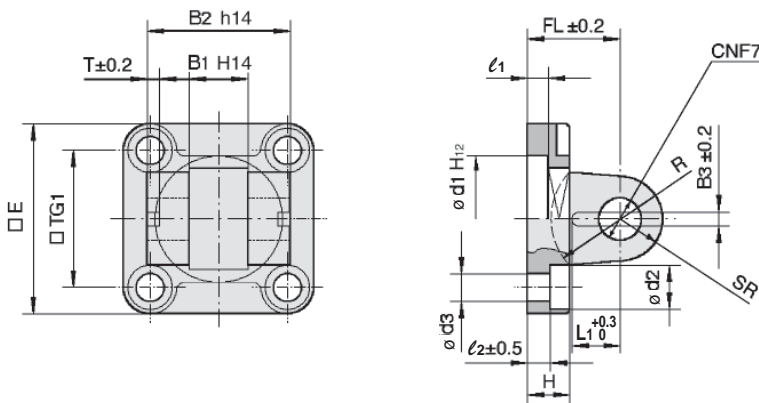

[mm]

Bore size	Part no.	B ₁	B ₂	B ₃	∅ CN	∅ d ₁	∅ d ₂	∅ d ₃	E	FL	H (Max.)	L ₁	l ₁ (Min.)	l ₂	R	SR (Max.)	T	TG ₁
32	DS5032	14	34	3.3	10	30	10.5	6.6	45	22	10	11.5	5	5.5	17	11	3	32.5
40	DS5040	16	40	4.3	12	35	11	6.6	55	25	10	12	5	5.5	20	13	4	38
50	DS5050	21	45	4.3	16	40	15	9	65	27	12	14	5	6.5	22	18	4	46.5
63	DS5063	21	51	4.3	16	45	15	9	75	32	12	14	5	6.5	25	18	4	56.5
80	DS5080	25	65	4.3	20	45	18	11	95	36	16	16	5	10	30	22	4	72
100	DS5100	25	75	6.3	20	55	18	11	115	41	16	16	5	10	32	22	4	89

* Supplied with 4 mounting screws, clevis pin, and clevis pin bracket

Clevis pivot bracket with ball joint (ES)

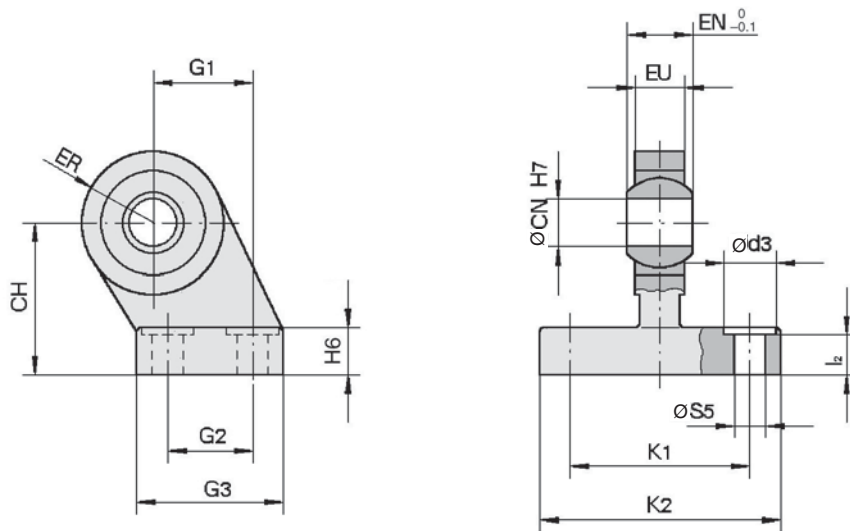

[mm]

Bore size	Part no.	CH	∅ CN	∅ d ₃	EN	ER (Max.)	EU	G ₁	G ₂	G ₃ (Max.)	H ₆	K ₁	K ₂ (Max.)	l ₂	∅ S ₅
32	ES5032	32	10	11	14	15	10.5	21	18	31	10	38	51	8.5	6.6
40	ES5040	36	12	11	16	18	12	24	22	35	10	41	54	8.5	6.6
50	ES5050	45	16	15	21	20	15	33	30	45	12	50	65	10.5	9
63	ES5063	50	16	15	21	23	15	37	35	50	12	52	67	10.5	9
80	ES5080	63	20	18	25	27	18	47	40	60	14	66	86	11.5	11
100	ES5100	71	20	18	25	30	18	55	50	70	15	76	96	12.5	11

Dimensions: Piston Rod Accessories

Floating joint: JA

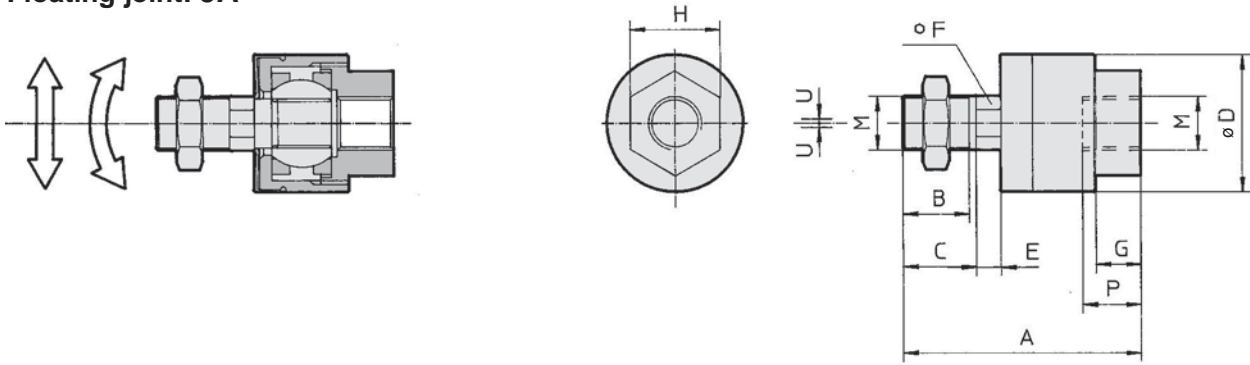

Bore size	Part no.	A	B	C	∅D	E	F	G	H	M	P	U	Load [kN]	Weight [g]	Rotating angle
32	JA30-10-125	49.5	19.5	—	24	5	8	8	17	M10 x 1.25	9	0.5	2.5	70	±0.5°
40	JA40-12-125	60	20	—	31	6	11	11	22	M12 x 1.25	13	0.75	4.4	160	
50, 63	JA50-16-150	71.5	22	—	41	7.5	14	13.5	27	M16 x 1.5	15	1	11	300	
80, 100	JAH50-20-150	101	28	31	59.5	11.5	24	16	32	M20 x 1.5	18	2	18	1080	

* Black colour

Rod clevis: GKM (ISO 8140)

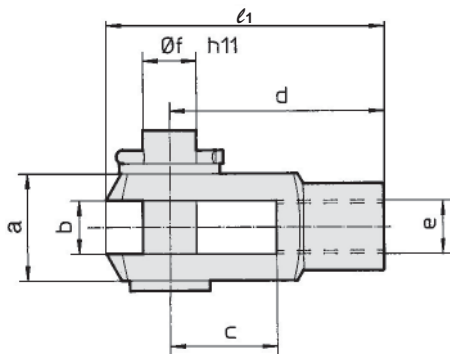

Bore size	Part no.	a (Max.)	b	c (Min.)	d	e	∅f H9 (Hole)	∅f h11 (Shaft)	l ₁
32	GKM10-20	20	10 ^{+0.5} / _{+0.15}	20	40	M10 x 1.25	10	10	52
40	GKM12-24	24	12 ^{+0.5} / _{+0.15}	24	48	M12 x 1.25	12	12	62
50, 63	GKM16-32	32	16 ^{+0.5} / _{+0.15}	32	64	M16 x 1.5	16	16	83
80, 100	GKM20-40	40	20 ^{+0.5} / _{+0.15}	40	80	M20 x 1.5	20	20	105

* Supplied with clevis pin and clevis pin bracket

Rod end: KJ (ISO 8139)

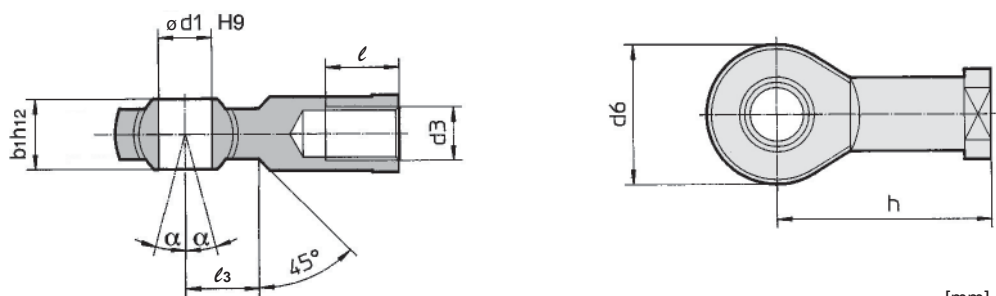

Bore size	Part no.	b ₁ h ₁₂	∅d ₁ H ₉	d ₃	d ₆ (Max.)	h	l (Min.)	l ₃	α
32	KJ10D	14	10	M10 x 1.25	28	43	20	15	4°
40	KJ12D	16	12	M12 x 1.25	32	50	22	17	4°
50, 63	KJ16D	21	16	M16 x 1.5	42	64	28	23	4°
80, 100	KJ20D	25	20	M20 x 1.5	50	77	33	27	4°

Model Selection
Working Principle
CP96N
Double Acting, Single Rod
Double Acting, Double Rod
C96N
Double Acting, Single Rod
Double Acting, Double Rod
Lock Unit
MWB-UT
Accessories
Auto Switch
Made to Order
Specific Product Precautions

CP96N Series Auto Switch Mounting

Auto Switch Proper Mounting Position (Detection at stroke end)

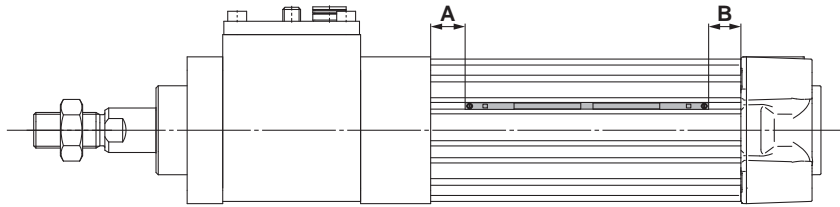

Auto Switch Proper Mounting Position [mm]

Auto switch model	D-M9□(V) D-M9□W(V) D-M9□A(V)		D-A9□(V)	
	A	B	A	B
Bore size 32	13.5	10.5	9.5	6.5
40	10.5	14	6.5	10
50	13	14.5	9	10.5
63	13	15.5	9	11.5
80	18.5	18	14.5	14
100	18.5	19	14.5	15

- * Adjust the auto switch after confirming the operating conditions in the actual setting.
- * The D-M9□V/M9□WV/M9□AV/A9□V are mountable on Ø 32 to Ø 63.

Minimum Stroke for Auto Switch Mounting

Auto switch model	Number of auto switches	32	40	50	63	80	100
D-M9□ D-M9□W	2 (Same surface)			50			
	1, 2 (Different surfaces)			10			
	n			10 + 40 (n - 2)			
D-M9□V D-M9□WV	2 (Same surface)		40				
	1, 2 (Different surfaces)		10				
	n		10 + 30 (n - 2)				
D-M9□A	2 (Same surface)	55			50		
	1, 2 (Different surfaces)	15			10		
	n	15 + 40 (n - 2)			10 + 40 (n - 2)		
D-M9□AV	2 (Same surface)		40				
	1, 2 (Different surfaces)		10				
	n		10 + 30 (n - 2)				
D-A9□	2 (Same surface)			50			
	1, 2 (Different surfaces)			10			
	n			10 + 40 (n - 2)			
D-A9□V	2 (Same surface)		40				
	1, 2 (Different surfaces)		10				
	n		10 + 30 (n - 2)				

- * n = 3, 4, 5...
- * The D-M9□V/M9□WV/M9□AV/A9□V are mountable on Ø 32 to Ø 63.

Operating Range

Auto switch model	Bore size					
	32	40	50	63	80	100
D-M9□(V)						
D-M9□W(V)	4	4	5	6	5.5	6
D-M9□A(V)						
D-A9□(V)	7	8	8.5	9.5	9.5	10.5

- * Values which include hysteresis are for reference purposes only. They are not a guarantee (assuming approximately ±30 % dispersion) and may change substantially depending on the ambient environment.
- * The D-M9□V/M9□WV/M9□AV/A9□V are mountable on Ø 32 to Ø 63.

Other than the applicable auto switches listed in "How to Order," the following auto switches are also mountable.

- * Normally closed (NC = b contact) solid state auto switches (D-M9□E) are also available. For details, refer to the [Web Catalogue](#).
- * With pre-wired connector is also available for solid state switches. For details, refer to the [Web Catalogue](#).

Prior to Use

Auto Switch Connections and Examples

Sink Input Specifications

3-wire, NPN

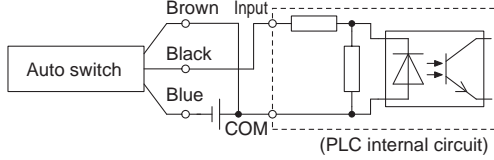

2-wire

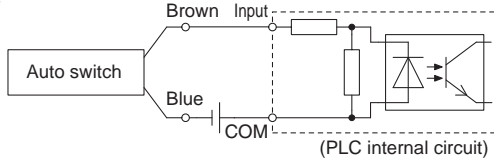

Source Input Specifications

3-wire, PNP

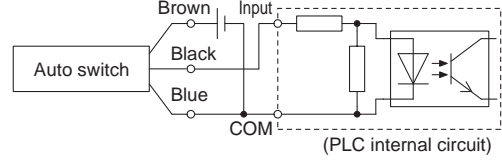

2-wire

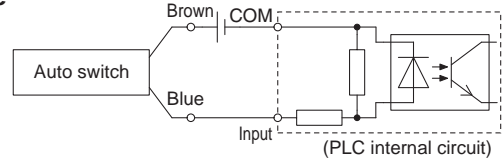

Connect according to the applicable PLC input specifications, as the connection method will vary depending on the PLC input specifications.

Examples of AND (Series) and OR (Parallel) Connections

* When using solid state auto switches, ensure the application is set up so the signals for the first 50 ms are invalid. Depending on the operating environment, the product may not operate properly.

3-wire AND connection for NPN output

(Using relays)

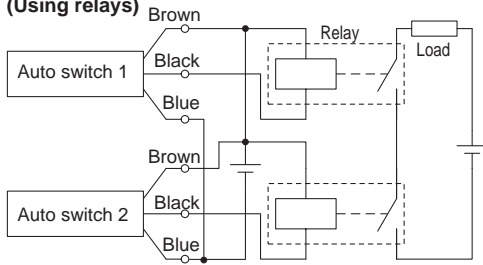

(Performed with auto switches only)

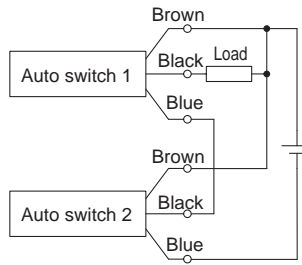

3-wire OR connection for NPN output

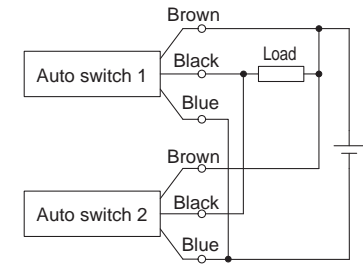

3-wire AND connection for PNP output

(Using relays)

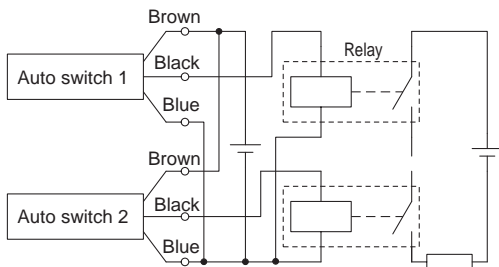

(Performed with auto switches only)

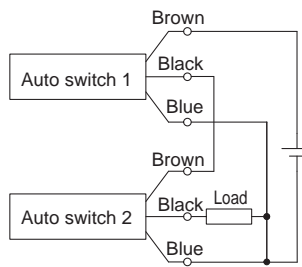

3-wire OR connection for PNP output

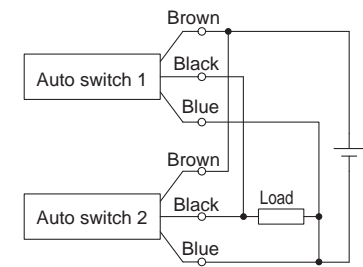

2-wire AND connection

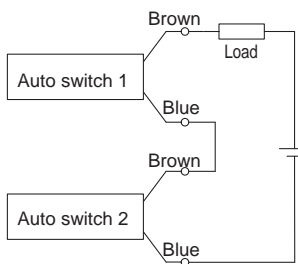

When two auto switches are connected in series, a load may malfunction because the load voltage will decline when in the ON state. The indicator lights will light up when both of the auto switches are in the ON state. Auto switches with a load voltage less than 20 V cannot be used.

$$\begin{aligned} \text{Load voltage at ON} &= \text{Power supply voltage} - \\ &\quad \text{Residual voltage} \times 2 \text{ pcs.} \\ &= 24 \text{ V} - 4 \text{ V} \times 2 \text{ pcs.} \\ &= 16 \text{ V} \end{aligned}$$

Example: Power supply is 24 VDC
Internal voltage drop in auto switch is 4 V.

2-wire OR connection

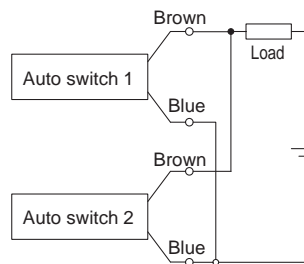

(Solid state)
When two auto switches are connected in parallel, malfunction may occur because the load voltage will increase when in the OFF state.

(Reed)
Because there is no current leakage, the load voltage will not increase when turned OFF. However, depending on the number of auto switches in the ON state, the indicator lights may sometimes grow dim or not light up, due to the dispersion and reduction of the current flowing to the auto switches.

$$\begin{aligned} \text{Load voltage at OFF} &= \text{Leakage current} \times 2 \text{ pcs.} \times \\ &\quad \text{Load impedance} \\ &= 1 \text{ mA} \times 2 \text{ pcs.} \times 3 \text{ k}\Omega \\ &= 6 \text{ V} \end{aligned}$$

Example: Load impedance is 3 k Ω .
Leakage current from auto switch is 1 mA.

Model Selection

Working Principle

CP96N
Double Acting, Single Rod

Double Acting, Double Rod

C96N

Double Acting, Single Rod

Double Acting, Double Rod

Lock Unit
MWB-UT

Accessories

Auto Switch

Made to Order

Specific Product Precautions

Cylinder with Lock

Double Acting, Single Rod/Double Rod

C96N Series

∅ 32, ∅ 40, ∅ 50, ∅ 63, ∅ 80, ∅ 100



How to Order

C96N **B** **32** - **100** **C** **J** **W** - [] - [] - []

With auto switch **C96N D** **B** **32** - **100** **C** **J** **W** - [] - [] - **M9BW** **S** - []

With auto switch
(Built-in magnet)

Mounting

Symbol	Description	Single rod	Double rod
B	Basic	○	○
L	Axial foot	○	○
F	Rod flange	○	○
G	Head flange	○	○
C	Single clevis	○	—
D	Double clevis	○	—
T	Centre trunnion	○	○

Bore size

32	32 mm
40	40 mm
50	50 mm
63	63 mm
80	80 mm
100	100 mm

Cylinder stroke
[mm]
Refer to page 26 for standard strokes.

Air cushion on both ends + Bumper cushion

Rod boot

—	Without rod boot
J	Nylon tarpaulin (One end)
JJ	Nylon tarpaulin (Both ends)
K	Heat-resistant tarpaulin (One end)
KK	Heat-resistant tarpaulin (Both ends)

Rod

—	Single rod
W	Double rod

Pivot bracket

—	No bracket
N	Pivot bracket

* Only for D and T mounting types
* The double clevis pivot bracket and clevis pivot bracket with ball joint should be ordered separately.

Rod end bracket

—	No bracket
W	Rod clevis

* The floating joint and rod end should be ordered separately.

Made to order
Refer to page 26 for details.

Number of auto switches

—	2
S	1
3	3
n	n

Auto switch

—	Without auto switch
---	---------------------

* For applicable auto switches, refer to the table below.

Refer to the Ordering Example of Cylinder Assembly on page 26.

Applicable Auto Switches/Refer to the Web Catalogue for further information on auto switches.

Type	Special function	Electrical entry	Indicator light	Wiring (Output)	Load voltage		Auto switch model			Lead wire length [m]				Pre-wired connector	Applicable load				
					DC	AC	Tie-rod mounting		Band mounting	0.5 (—)	1 (M)	3 (L)	5 (Z)		IC circuit	Relay, PLC			
							Perpendicular	In-line											
Solid state auto switch	—	Grommet	No	3-wire (NPN)	24 V	5 V, 12 V	—	M9NV	M9N	—	●	●	●	○	○	○	IC circuit		
				3-wire (PNP)				M9PV	M9P		●	●	●	○					
		2-wire		M9BV				M9B	●		●	●	○						
		3-wire (NPN)		—				—	G39		—	—	—	—					
	Diagnostic indication (2-colour indicator)	Terminal conduit	Yes	No	3-wire (NPN)	24 V	5 V, 12 V	—	M9NVV	M9NV	—	●	●	●	○	○	○	IC circuit	
					3-wire (PNP)				M9PVV	M9PV		●	●	●	○				
					2-wire				M9BVV	M9BV		●	●	●	○				
					3-wire (NPN)				M9NAV*1	M9NA*1		—	○	○	●				○
					3-wire (PNP)				M9PAV*1	M9PA*1		—	○	○	●				○
					2-wire				M9BAV*1	M9BA*1		—	○	○	●				○
Reed auto switch	—	Grommet	Yes	3-wire (NPN equivalent)	24 V	12 V	—	A96V	A96	—	●	—	●	—	—	—	IC circuit		
				100 V				A93V*2	A93		●	—	●	—					
				100 V or less				A90V	A90		●	—	●	—					
				100 V, 200 V				—	A54		●	—	●	—					
				200 V or less				—	A64		●	—	●	—					
		Terminal conduit	Yes	No	No	2-wire	24 V	12 V	—	—	—	—	—	—	—	—	—	—	
										—	—		A33	—	—				—
										—	—		A34	—	—				—
										100 V, 200 V	—		A44	—	—				—
										—	—		A59W	—	—				—
DIN terminal	Yes	No	No	2-wire	24 V	12 V	—	—	—	—	—	—	—	—	—	—			
								—	—		—	—					—		
Diagnostic indication (2-colour indicator)	Grommet	Yes	No	2-wire	24 V	12 V	—	—	—	—	●	—	●	—	—	—			
								—	—		—	—	—						

*1 Water-resistant type auto switches can be mounted on the above models, but SMC cannot guarantee water resistance.

A water-resistant type cylinder is recommended for use in an environment which requires water resistance.

*2 The 1 m lead wire is only applicable to the D-A93.

* Lead wire length symbols: 0.5 m..... (Example) M9NW 3 m..... L (Example) M9NWL
1 m.....M (Example) M9NWM 5 m..... Z (Example) M9NWZ

* Solid state auto switches marked with "○" are produced upon receipt of order.

* Since there are applicable auto switches other than those listed above, refer to page 42 for details.

* The D-A9□/M9□/P3DWA□ auto switches are shipped together with the product but do not come assembled. (Only the auto switch mounting brackets are assembled for the D-A9□/M9□ before shipment.)

Cylinder with Lock Double Acting, Single Rod/Double Rod **C96N Series**

Cylinder Specifications



Made to Order Common Specifications (For details, refer to pages 46 to 48.)

Symbol	Specifications
-XA□	Change of rod end shape (Single rod only)
-XC35	With coil scraper

For details of **cylinders with auto switches**
⇒ pages 36 to 42

- Auto Switch Proper Mounting Position (Detection at stroke end) and Mounting Height
- Minimum Stroke for Auto Switch Mounting
- Auto Switch Mounting Brackets/Part Nos.
- Operating Range

Ordering Example of Cylinder Assembly

Cylinder model: C96NDD50-100C-NW-M9BW

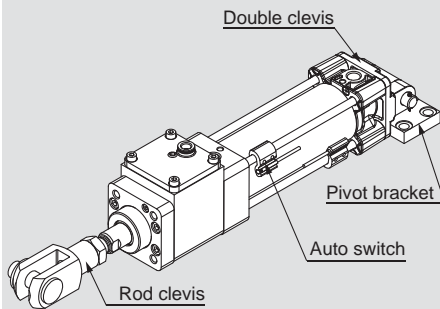

Mounting D: Double clevis
Pivot bracket N: Yes
Rod end bracket W: Rod clevis
Auto switch D-M9BW: 2 pcs.

* Pivot bracket, rod clevis, and auto switch are shipped together with the product but do not come assembled.

Bore size [mm]	32	40	50	63	80	100
Action	Double acting					
Fluid	Air					
Proof pressure	1.5 MPa					
Max. operating pressure	1.0 MPa					
Min. operating pressure	0.08 MPa					
Ambient and fluid temperatures	Without auto switch: -10 °C to 70 °C With auto switch: -10 °C to 60 °C (No freezing)					
Lubricant	Not required (Non-lube)					
Piston speed	50 to 1000 mm/s*1					
Stroke length tolerance	Up to 500 st: $^{+2.0}_0$, 501 to 1000 st: $^{+2.4}_0$, 1001 to 1500 st: $^{+2.8}_0$, 1501 to 1900 st: $^{+3.2}_0$					
Cushion	Air cushion on both ends + Bumper cushion					
Port size	G1/8	G1/4	G3/8	G3/8	G1/2	G1/2
Mounting	Basic, Axial foot, Rod flange, Head flange Single clevis, Double clevis, Centre trunnion					

*1 Load limits exist depending upon the piston speed when locked, mounting direction, and operating pressure.

Lock Unit Specifications

Bore size [mm]	32	40	50	63	80	100
Locking action	Exhaust locking					
Max. operating pressure	1.0 MPa					
Min. operating pressure	0.3 MPa					
Locking direction	Both directions					
Holding force (Max. static load) [N]*1	630	980	1570	2450	3920	6080

*1 The holding force (max. static load) shows the maximum capability and does not show the normal holding capability. Be sure to select a cylinder using the method described in Model Selection (page 6).

Standard Strokes

* When using with auto switches, refer to the Minimum Stroke for Auto Switch Mounting table on pages 38 to 40.

Bore size	Standard stroke	Max. stroke
32	25, 50, 80, 100, 125, 160, 200, 250, 320, 400, 500	1000
40	25, 50, 80, 100, 125, 160, 200, 250, 320, 400, 500	1900
50	25, 50, 80, 100, 125, 160, 200, 250, 320, 400, 500, 600	1900
63	25, 50, 80, 100, 125, 160, 200, 250, 320, 400, 500, 600	1900
80	25, 50, 80, 100, 125, 160, 200, 250, 320, 400, 500, 600, 700, 800	1900
100	25, 50, 80, 100, 125, 160, 200, 250, 320, 400, 500, 600, 700, 800	1900

- * The manufacturing of intermediate strokes is possible. (Spacers are not used.)
- * Applicable strokes should be confirmed according to the usage. For details, refer to the Air Cylinders Model Selection in the **Web Catalogue**. In addition, products that exceed the standard stroke might not be able to fulfill the specifications due to deflection, etc.
- * When using a rod boot, a stroke range of up to 1000 mm is available. Please consult with SMC when exceeding a 1000 mm stroke.

Stopping Accuracy

Bore size [mm]	32	40	50	63	80	100
Lock type	Exhaust locking					
Stopping accuracy [mm]	±1.0					
Conditions	<ul style="list-style-type: none"> • Mounting orientation: Horizontal • Supply pressure: 0.5 MPa • Piston speed: 300 mm/s • Load condition: Upper limit of allowed value Solenoid valve for locking is mounted on the unlock port. Maximum value of stopping position dispersion from 100 measurements					

Model Selection
Working Principle
CP96N
Double Acting, Single Rod
Double Acting, Double Rod
C96N
Double Acting, Single Rod
Double Acting, Double Rod
Lock Unit MWB-UT
Accessories
Auto Switch
Made to Order
Specific Product Precautions

C96N Series

Accessories

Mounting		Basic	Axial foot	Rod flange	Head flange	Single clevis	Double clevis	Centre trunnion
Standard	Rod end nut	●	●	●	●	●	●	●
	Clevis pin	—	—	—	—	—	●	—
Option	Rod end	●	●	●	●	●	●	●
	Rod clevis	●	●	●	●	●	●	●
	Rod boot	●	●	●	●	●	●	●

- * Do not use a rod end (or floating joint) together with a single clevis with a ball joint (or clevis pivot bracket with a ball joint).
- * Refer to pages 19 to 22 for dimensions and part numbers of the accessories. (Excludes the rod end nut, clevis pin, and rod boot)

Mounting Bracket/Rod End Bracket Part Nos.

Bore size [mm]		32	40	50	63	80	100
L	Axial foot*1	L5032	L5040	L5050	L5063	L5080	L5100
F, G	Rod/Head flange	F5032	F5040	F5050	F5063	F5080	F5100
C	Single clevis	C5032	C5040	C5050	C5063	C5080	C5100
D	Double clevis	D5032	D5040	D5050	D5063	D5080	D5100
E	Clevis pivot bracket	E5032	E5040	E5050	E5063	E5080	E5100
CS	Single clevis with ball joint	CS5032	CS5040	CS5050	CS5063	CS5080	CS5100
DS	Double clevis pivot bracket for ES accessory	DS5032	DS5040	DS5050	DS5063	DS5080	DS5100
ES	Clevis pivot bracket with ball joint	ES5032	ES5040	ES5050	ES5063	ES5080	ES5100
GKM	Rod clevis	GKM10-20	GKM12-24	GKM16-32	GKM16-32	GKM20-40	GKM20-40
KJ	Rod end	KJ10D	KJ12D	KJ16D	KJ16D	KJ20D	KJ20D
JA	Floating joint	JA30-10-125	JA40-12-125	JA50-16-150	JA50-16-150	JAH50-20-150	JAH50-20-150

- *1 Order two foot brackets per cylinder.
- * Accessories for each mounting bracket are as follows.
Axial foot, Rod/Head flange, Single clevis: Body mounting bolt
Double clevis (D, DS): Body mounting bolt, Clevis pin, Clevis pin bracket
- * The rod clevis (GKM) is compliant with ISO 8140.
- * The rod end (KJ) is compliant with ISO 8139.

Theoretical Output



(Unit: N)

Bore size [mm]	Rod size [mm]	Operating direction	Piston area [mm ²]	Operating pressure [MPa]								
				0.2	0.3	0.4	0.5	0.6	0.7	0.8	0.9	1.0
32	12	OUT	804	161	241	322	402	482	563	643	724	804
		IN	691	138	207	276	346	415	484	553	622	691
40	16	OUT	1257	251	377	503	629	754	880	1006	1131	1257
		IN	1056	211	317	422	528	634	739	845	950	1056
50	20	OUT	1963	393	589	785	982	1178	1374	1570	1767	1963
		IN	1649	330	495	660	825	989	1154	1319	1484	1649
63	20	OUT	3117	623	935	1247	1559	1870	2182	2494	2805	3117
		IN	2803	561	841	1121	1402	1682	1962	2242	2523	2803
80	25	OUT	5027	1005	1508	2011	2514	3016	3519	4022	4524	5027
		IN	4536	907	1361	1814	2268	2722	3175	3629	4082	4536
100	30	OUT	7854	1571	2356	3142	3927	4712	5498	6283	7069	7854
		IN	7147	1429	2144	2859	3574	4288	5003	5718	6432	7147

* Theoretical output [N] = Pressure [MPa] x Piston area [mm²]

Weight

Single Rod (Ø 32 to Ø 100)

[kg]

Bore size [mm]		32	40	50	63	80	100	
Basic weight (at 0 stroke)	Basic	Lock unit	0.42	0.83	1.15	1.79	2.81	5.44
		Cylinder (at 0 stroke)	0.53	0.82	1.37	1.74	3.16	4.50
		Total	0.95	1.65	2.52	3.53	5.97	9.94
Mounting bracket weight (including bracket mounting bolts)	Foot bracket (2 pcs.)		0.16	0.20	0.38	0.46	0.89	1.09
	Rod/Head flange		0.20	0.23	0.47	0.58	1.30	1.81
	Single clevis bracket		0.16	0.23	0.37	0.60	1.07	1.73
	Double clevis bracket		0.20	0.32	0.45	0.71	1.28	2.11
Trunnion bracket		0.17	0.29	0.38	0.64	1.12	1.85	
Additional weight per 50 mm of stroke		0.11	0.16	0.24	0.26	0.40	0.44	
Accessories	Rod end		0.07	0.11	0.22	0.40	0.40	
	Rod clevis		0.09	0.15	0.34	0.69	0.69	

Rod Boot Material

Symbol	Material	Max. ambient temp.
J	Nylon tarpaulin	70 °C
K	Heat-resistant tarpaulin	110 °C*1

*1 Max. ambient temperature for rod boot itself

Allowable Kinetic Energy of the Cylinder*1

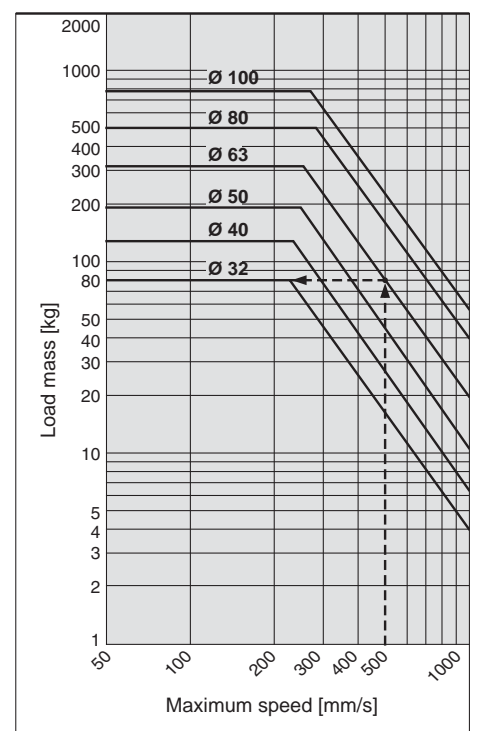

Example) Load limit at rod end when the air cylinder Ø 63 is actuated at 500 mm/s.
Extend upward from 500 mm/s on the horizontal axis of the graph to the intersection point with the line for a tube bore size of 63 mm, and then extend leftward from this point to find the load of 80 kg.

*1 The allowable kinetic energy of the cylinder is shown without the intermediate stop or emergency stop. Refer to page 6 or 7 for the kinetic energy with intermediate or emergency stop.

Calculation example)

C96NL32-100C (Axial foot, Ø 32, 100 mm stroke)

- Basic weight...0.42 (Lock unit, Ø 32)
- Basic weight...0.53 (Cylinder, Ø 32)
- Additional weight...0.11/50 mm stroke
- Cylinder stroke...100 mm stroke
- Foot bracket...0.16

$$0.42 + 0.53 + (0.11/50) \times 100 + 0.16 = 1.33 \text{ kg}$$

Construction (Single Rod)

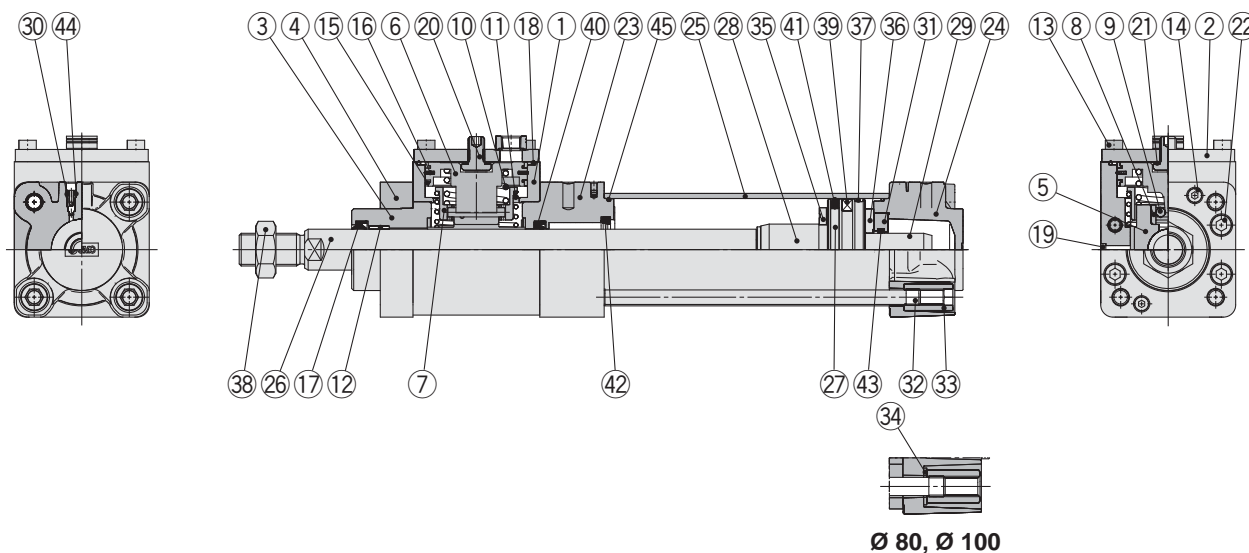

Component Parts

No.	Description	Material	Qty.	Note
1	Brake unit	Aluminium alloy	1	Hard anodised
2	Cap	Rolled steel	1	Zinc chromated
3	Collar	Aluminium alloy	1	Zinc chromated
4	Retaining plate	Aluminium alloy	1	Anodised
5	Brake pad	Cast iron	1	
6	Piston A	Aluminium alloy	1	
7	Roller holder	Carbon steel	1	
8	Roller receiver	Stainless steel	2	
9	Needle roller	Carbon steel	2	
10	Piston spring	Spring steel	1	Zinc chromated
11	Roller spring	Spring steel	1	Zinc chromated
12	Bushing	Bearing alloy	1	
13	Hexagon socket head cap screw	Alloy steel	4	
14	Hexagon socket head cap screw	Alloy steel	2	
15	Wear ring A	Resin	2	
16	Piston seal A	NBR	1	
17	Rod seal A	NBR	1	
18	Gasket	NBR	1	
19	Element	Bronze	1	
20	Release bolt	Alloy steel	1	
21	Seal washer	NBR + Stainless steel	1	
22	Hexagon socket head cap screw	Alloy steel	4	
23	Rod cover	Aluminium alloy	1	Anodised
24	Head cover	Aluminium die-cast	1	Zinc chromated
25	Cylinder tube	Aluminium alloy	1	Hard anodised
26	Piston rod	Carbon steel	1	Hard chrome plating
27	Piston B	Aluminium alloy	1	Ø 32 to Ø 63
		Aluminium die-cast	1	Ø 80, Ø 100
28	Cushion ring	Aluminium alloy	1	Anodised
29	Cushion ring B	Aluminium alloy	1	Anodised
30	Cushion valve	Resin	2	
31	Cushion seal holder	Aluminium alloy	1	Anodised

Component Parts

No.	Description	Material	Qty.	Note
32	Tie-rod	Carbon steel	4	Zinc chromated
33	Tie-rod nut	Rolled steel	8	Zinc chromated
34	Flat washer	Steel	8	Ø 80, Ø 100
35	Bumper A	Urethane	1	
36	Bumper B	Urethane	1	
37	Wear ring B	Resin	1	
38	Rod end nut	Carbon steel	1	Zinc chromated
39	Magnet	—	(1)	
40	Rod seal B	NBR	1	
41	Piston seal B	NBR	1	
42	Cushion seal A	Urethane	1	
43	Cushion seal B	Urethane	1	
44	Cushion valve seal	NBR	2	
45	Cylinder tube gasket	NBR	2	

Replacement Parts/Seal Kit

Bore size [mm]	Kit no.	Contents
32	C96N32-PS	A set of 17 Rod seal A, 40 Rod seal B, 41 Piston seal B, 42 Cushion seal A, 43 Cushion seal B, and 45 Cylinder tube gasket
40	C96N40-PS	
50	C96N50-PS	
63	C96N63-PS	
80	C96N80-PS	
100	C96N100-PS	

* Never disassemble the lock unit. It should be replaced as a unit. Refer to page 52 for the part numbers for placing an order. The seal kit shown above contains the rod seal for the cylinder and lock unit. Order the seal kit suitable for the cylinder bore size.

* The seal kit shown above includes a grease pack.
(Ø 32, Ø 40, Ø 50: 10 g, Ø 63, Ø 80: 20 g, Ø 100: 30 g)
Order with the following part number when only the grease pack is needed.
Grease pack part number: GR-S-010 (10 g), GR-S-020 (20 g)

C96N Series

Dimensions (Single Rod)

Basic: C96NB

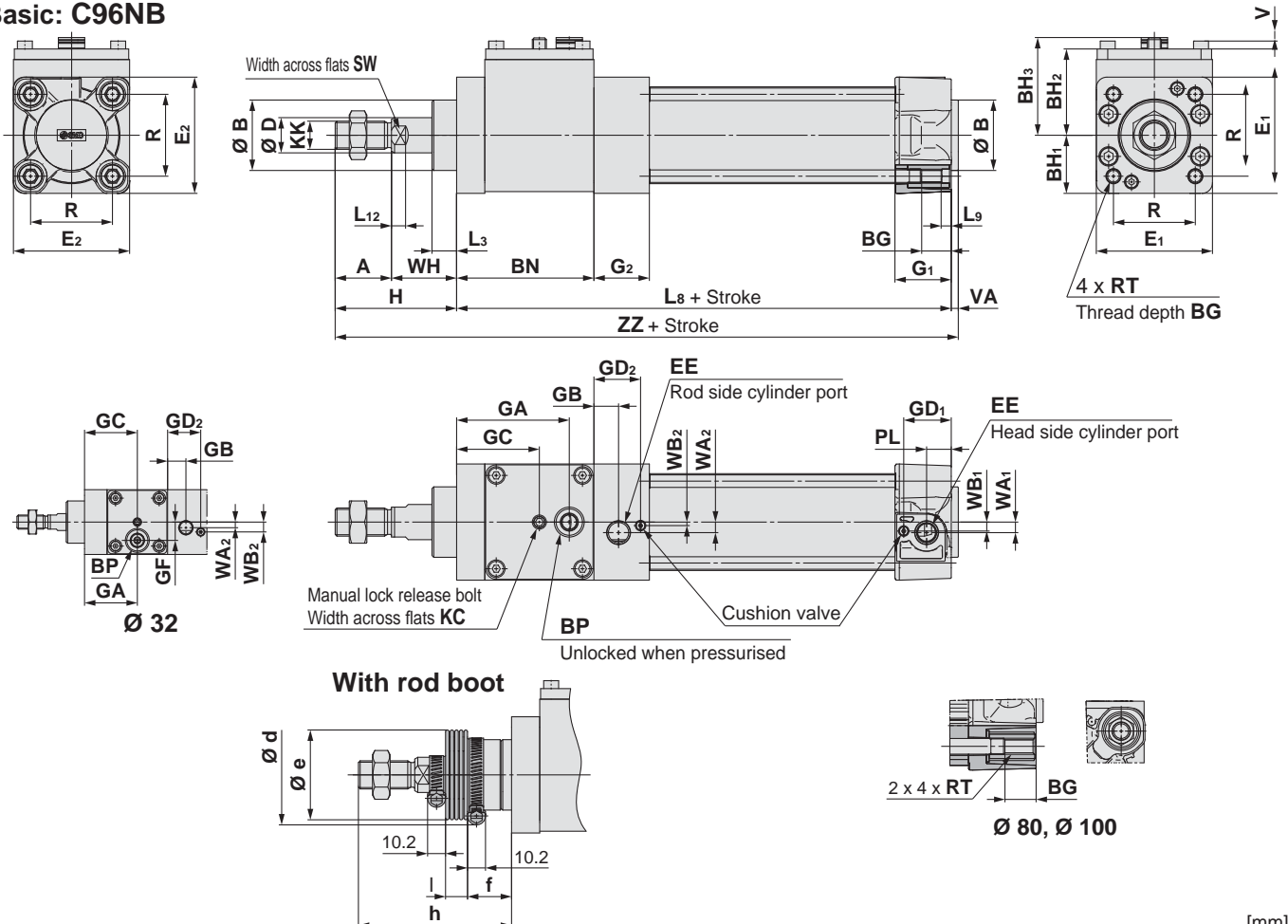

Bore size	Stroke range	A	Ø B _{d11}	BG	BH ₁	BH ₂	BH ₃	BN	BP	Ø D	E ₁	E ₂	EE	G ₁	G ₂	GA	GB	GC	GD ₁	GD ₂	GF	H
32	Up to 1000	22	30	16	23	38.5	46.5	59	G1/8	12	46	47	G1/8	28.9	28.5	37.5	13	37.5	23.9	23.5	13	48
40	Up to 1900	24	35	16	28.5	42.5	48.5	73	G1/8	16	57	54	G1/4	32.6	29	59.5	14	44.5	27.6	24	—	54
50	Up to 1900	32	40	16	33	49	55.5	78	G1/8	20	66	66	G1/4	32	31.5	64	14	47	27	26.5	—	69
63	Up to 1900	32	45	16	39	52.5	59.5	90	G1/4	20	78	77	G3/8	38.6	31.5	73	16	53	31.6	26.5	—	69
80	Up to 1900	40	45	17	49	64.5	71.5	113	G1/4	25	98	99	G3/8	38.4	38	92	16	65	32	31.6	—	86
100	Up to 1900	40	55	17	58	73.5	80.5	131	G1/4	30	116	118	G1/2	42.9	38	109	18	74	36.5	31.6	—	91

Bore size	Stroke range	KC	KK	L ₃	L ₈	L ₉	L ₁₂	PL	R	RT	SW	V	VA	WA ₁	WA ₂	WB ₁	WB ₂	WH	ZZ
32	Up to 1000	3	M10 x 1.25	13	152	4	6	13	32.5	M6 x 1	10	3.5	4	4	4	7	7	26	204
40	Up to 1900	3	M12 x 1.25	13	171	4	6.5	14	38	M6 x 1	13	4.5	4	5	7	8.9	1.8	30	229
50	Up to 1900	4	M16 x 1.5	14	181	5	8	14	46.5	M8 x 1.25	17	4.5	4	6	6	5.1	2	37	254
63	Up to 1900	4	M16 x 1.5	14	200.5	5	8	16	56.5	M8 x 1.25	17	5.5	4	9	9	6.3	2	37	273.5
80	Up to 1900	5	M20 x 1.5	20	238	—	10	16	72	M10 x 1.5	22	7.5	4	11.5	11.5	6	6	46	328
100	Up to 1900	5	M20 x 1.5	20	261.5	—	10	18	89	M10 x 1.5	26	9.5	4	17	17	10	3	51	356.5

With Rod Boot

Bore size	d	e	f	h												
				1 to 50	51 to 100	101 to 150	151 to 200	201 to 300	301 to 400	401 to 500	501 to 600	601 to 700	701 to 800	801 to 900	901 to 1000	
32	54	36	23	75	88	100	113	138	163	188	213	238	263	288	313	
40	56	41	23	75	88	100	113	138	163	188	213	238	263	288	313	
50	64	51	25	87	100	112	125	150	175	200	225	250	275	300	325	
63	64	51	25	87	100	112	125	150	175	200	225	250	275	300	325	
80	68	56	29	103	116	128	141	166	191	216	241	266	291	316	341	
100	76	61	29	103	116	128	141	166	191	216	241	266	291	316	341	

Bore size	l												
	1 to 50	51 to 100	101 to 150	151 to 200	201 to 300	301 to 400	401 to 500	501 to 600	601 to 700	701 to 800	801 to 900	901 to 1000	
32	12.5	25	37.5	50	75	100	125	150	175	200	225	250	
40	12.5	25	37.5	50	75	100	125	150	175	200	225	250	
50	12.5	25	37.5	50	75	100	125	150	175	200	225	250	
63	12.5	25	37.5	50	75	100	125	150	175	200	225	250	
80	12.5	25	37.5	50	75	100	125	150	175	200	225	250	
100	12.5	25	37.5	50	75	100	125	150	175	200	225	250	

Dimensions: With Mounting Bracket

* Refer to Basic (B) for other dimensions.

Axial foot: C96NL

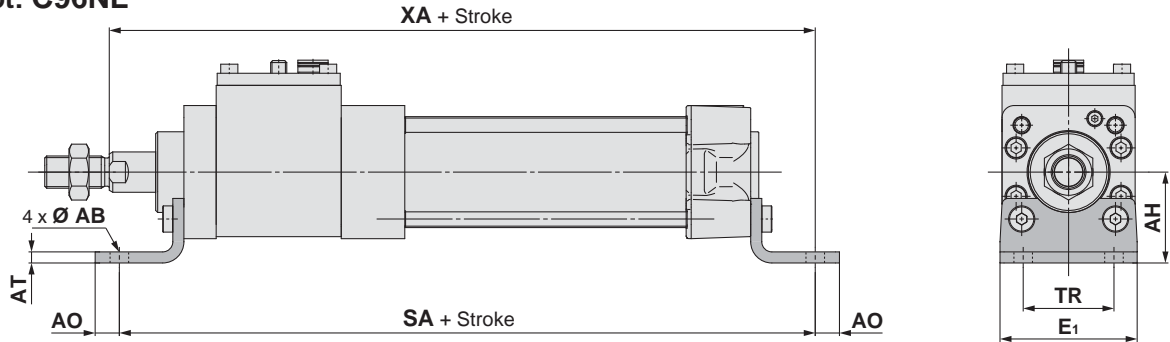

Bore size	AB	AH	AO	AT	E ₁	SA	TR	XA
32	7	32	10	4.5	48	200	32	202
40	10	36	11	4.5	55	227	36	229
50	10	45	12	5.5	68	245	45	250
63	10	50	12	5.5	80	264.5	50	269.5
80	12	63	14	6.5	100	320	63	325
100	14.5	71	16	6.5	120	343.5	75	353.5

Flange

Rod side: C96NF

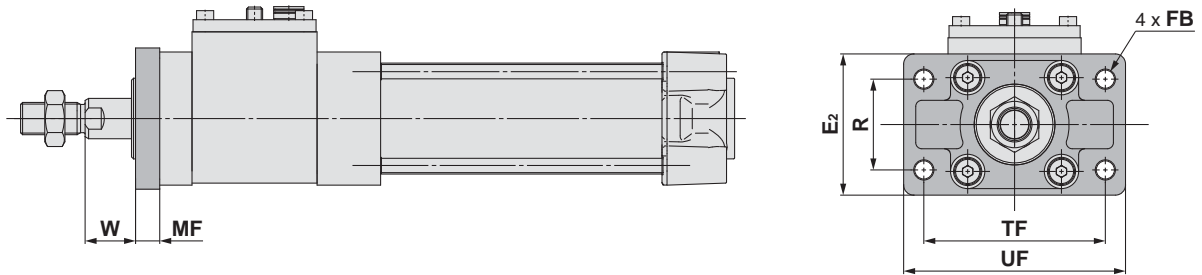

Head side: C96NG

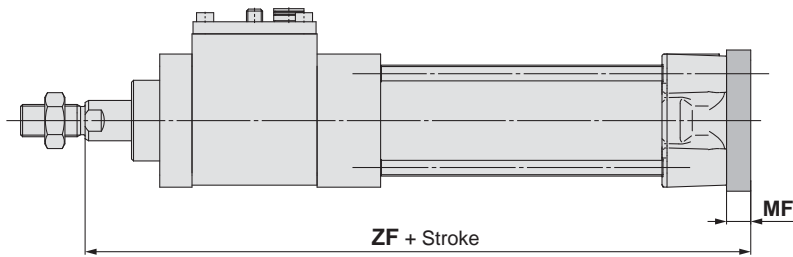

Bore size	E ₂	FB	MF	R	TF	UF	W	ZF
32	50	7	10	32	64	79	16	188
40	55	9	10	36	72	90	20	211
50	70	9	12	45	90	110	25	230
63	80	9	12	50	100	120	25	249.5
80	100	12	16	63	126	153	30	300
100	120	14	16	75	150	178	35	328.5

Model Selection

Working Principle

CP96N

Double Acting, Single Rod

Double Acting, Double Rod

C96N

Double Acting, Single Rod

Double Acting, Double Rod

Lock Unit
MWB-UT

Accessories

Auto Switch

Made to Order

Specific Product Precautions

C96N Series

Dimensions: With Mounting Bracket

* Refer to Basic (B) for other dimensions.

Single clevis: C96NC

Double clevis: C96ND

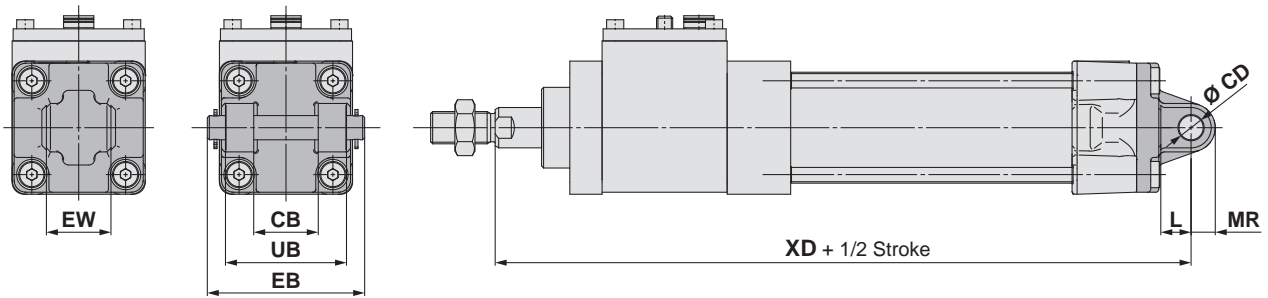

[mm]								
Bore size	CB _{H14}	CD _{H9}	EB	EW	L	MR	UB _{H14}	XD
32	26	10	65	26 ^{-0.2} _{-0.6}	12	9.5	45	200
40	28	12	75	28 ^{-0.2} _{-0.6}	15	12	52	226
50	32	12	80	32 ^{-0.2} _{-0.6}	15	12	60	245
63	40	16	90	40 ^{-0.2} _{-0.6}	20	16	70	269.5
80	50	16	110	50 ^{-0.2} _{-0.6}	20	16	90	320
100	60	20	140	60 ^{-0.2} _{-0.6}	25	20	110	353.5

Centre trunnion: C96NT

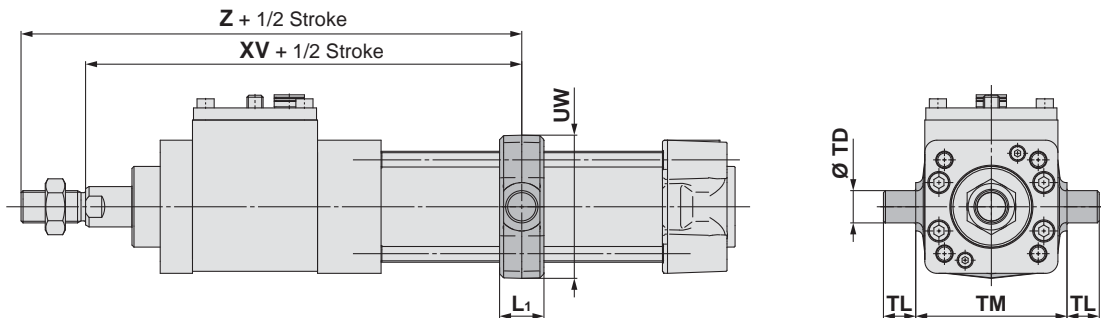

[mm]							
Bore size	L ₁	TD _{e8}	TL	TM	UW	XV	Z
32	17	12	12	50	49	131	153
40	22	16	16	63	58	150	174
50	22	16	16	75	71	166	198
63	28	20	20	90	87	179	211
80	34	20	20	110	110	221	261
100	40	25	25	132	136	245	285

Pivot Bracket: Trunnion and Double Clevis Pivot Bracket

Part Nos.

Bore size [mm]	32	40	50	63	80	100
Trunnion pivot bracket*1	MB-S03	MB-S04	MB-S04	MB-S06	MB-S06	MB-S10
Double clevis pivot bracket	E5032	E5040	E5050	E5063	E5080	E5100

*1 Order 2 trunnion pivot brackets per cylinder.

Trunnion pivot bracket

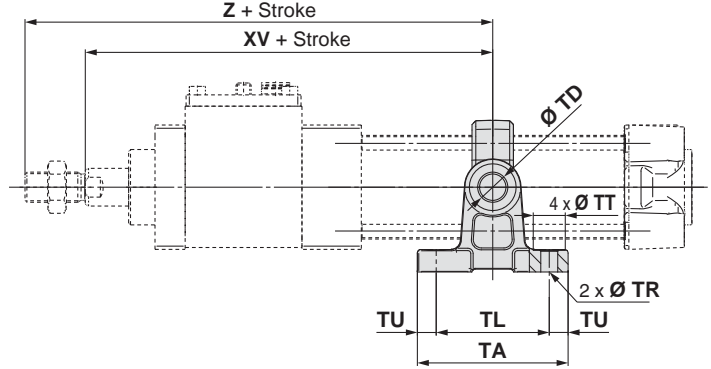
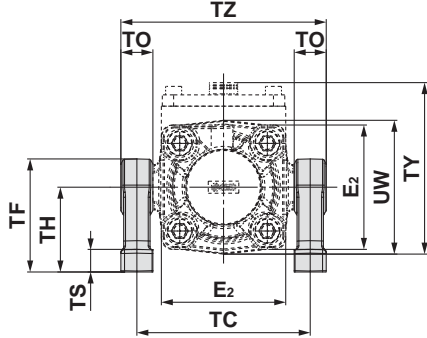

Bore size	Part no.	E ₂	TA	TC	TD	TF	TH	TL	TO	TR	TS	TT	TU	TX	TY	TZ	UW	XV	Z
32	MB-S03	47	62	62	12 ^{+0.070} ₀	47	35	45	12	7	10	13	8.5	50	71	74	49	131	153
40	MB-S04	54	80	80	16 ^{+0.070} ₀	60	45	60	17	9	12	17	10	63	77.5	97	58	150	174
50		66	80	92	16 ^{+0.070} ₀	60	45	60	17	9	12	17	10	75	91	109	71	166	198
63	MB-S06	77	100	110	20 ^{+0.084} ₀	80	60	70	20	11	14	22	15	90	103	130	87	179	211
80		99	100	130	20 ^{+0.084} ₀	80	60	70	20	11	14	22	15	110	126.5	150	110	221	261
100	MB-S10	118	120	158	25 ^{+0.084} ₀	100	75	90	26	13.5	17	24	15	132	148.5	184	136	245	285

Double clevis pivot bracket

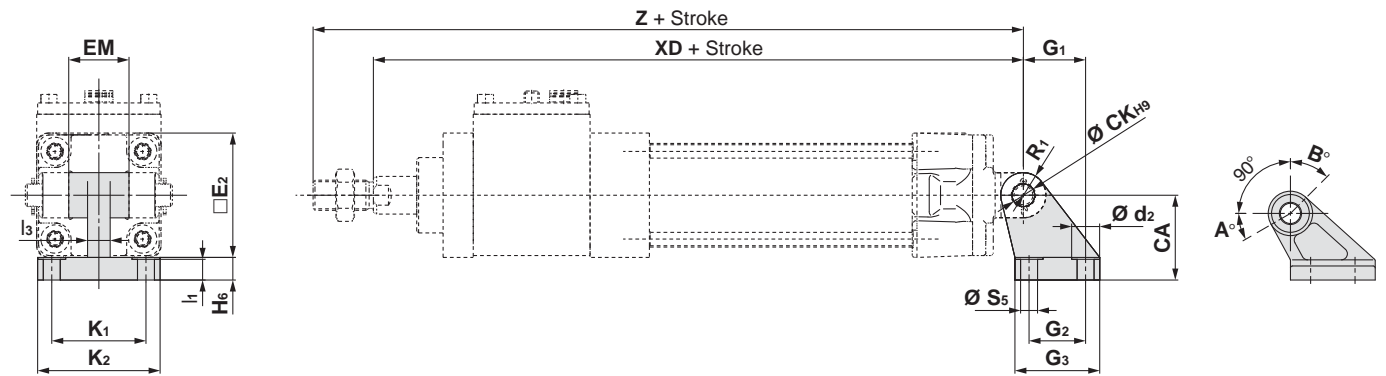

Bore size	Part no.	CA	Ø CK	Ø d ₂	E ₂	EM	G ₁	G ₂	G ₃ (Max.)	H ₆	K ₁	K ₂ (Max.)	l ₁	l ₃ (Max.)	R ₁	Ø S ₅	XD	Z
32	E5032	32	10	11	47	26 ^{-0.2} _{-0.6}	21	18	31	8	38	51	7	10	10	6.6	200	222
40	E5040	36	12	11	54	28 ^{-0.2} _{-0.6}	24	22	35	10	41	54	9	10	11	6.6	226	250
50	E5050	45	12	15	66	32 ^{-0.2} _{-0.6}	33	30	45	12	50	65	11	12	12	9	245	277
63	E5063	50	16	15	77	40 ^{-0.2} _{-0.6}	37	35	50	12	52	67	11	14	15	9	269.5	301.5
80	E5080	63	16	18	99	50 ^{-0.2} _{-0.6}	47	40	60	14	66	86	12.5	18	15	11	320	360
100	E5100	71	20	18	118	60 ^{-0.2} _{-0.6}	55	50	70	15	76	96	13.5	20	19	11	353.5	393.5

Rotating Angle

Bore size [mm]	A°	B°	A° + B° + 90°
32, 40	25°	45°	160°
50, 63	40°	60°	190°
80, 100	30°	55°	175°

Model Selection

Working Principle

CP96N

Double Acting, Single Rod

Double Acting, Double Rod

C96N

Double Acting, Single Rod

Double Acting, Double Rod

Lock Unit MWB-UT

Accessories

Auto Switch

Made to Order

Specific Product Precautions

C96N Series

Construction (Double Rod)

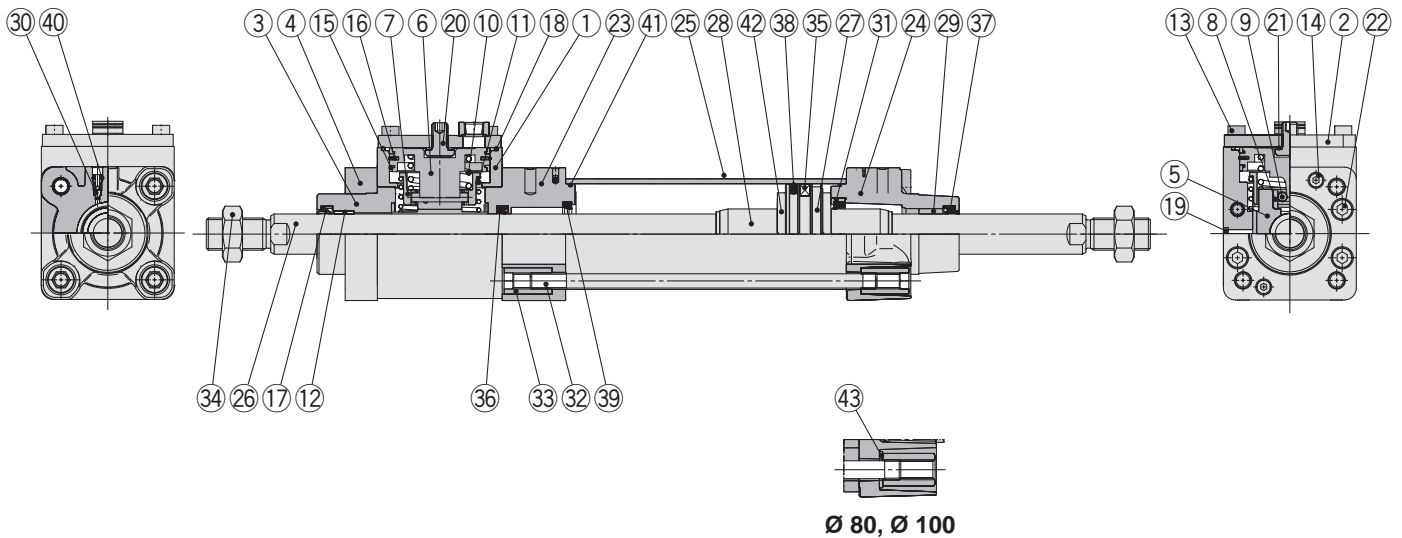

Component Parts

No.	Description	Material	Qty.	Note
1	Brake unit	Aluminium alloy	1	Hard anodised
2	Cap	Rolled steel	1	Zinc chromated
3	Collar	Aluminium alloy	1	Chromated
4	Retaining plate	Aluminium alloy	1	Anodised
5	Brake pad	Cast iron	1	
6	Piston A	Aluminium alloy	1	
7	Roller holder	Carbon steel	1	
8	Roller receiver	Stainless steel	2	
9	Needle roller	Carbon steel	2	
10	Piston spring	Spring steel	1	Zinc chromated
11	Roller spring	Spring steel	1	Zinc chromated
12	Bushing A	Bearing alloy	1	
13	Hexagon socket head cap screw	Alloy steel	4	
14	Hexagon socket head cap screw	Alloy steel	2	
15	Wear ring	Resin	2	
16	Piston seal A	NBR	1	
17	Rod seal A	NBR	1	
18	Gasket	NBR	1	
19	Element	Bronze	1	
20	Release bolt	Alloy steel	1	
21	Seal washer	NBR + Stainless steel	1	
22	Hexagon socket head cap screw	Alloy steel	4	
23	Rod cover A	Aluminium alloy	1	Anodised
24	Rod cover B	Aluminium die-cast	1	Zinc chromated
25	Cylinder tube	Aluminium alloy	1	Hard anodised
26	Piston rod	Carbon steel	1	Hard chrome plating
27	Piston B	Aluminium alloy	1	
28	Cushion ring	Aluminium alloy	2	Anodised
29	Bushing B	Bearing alloy	1	
30	Cushion valve	Resin	2	

Component Parts

No.	Description	Material	Qty.	Note
31	Cushion seal holder	Aluminium alloy	1	Anodised
32	Tie-rod	Carbon steel	4	Zinc chromated
33	Tie-rod nut	Rolled steel	8	Zinc chromated
34	Rod end nut	Carbon steel	2	Zinc chromated
35	Magnet	—	(1)	
36	Rod seal B	NBR	1	
37	Rod seal C	NBR	1	
38	Piston seal B	NBR	1	
39	Cushion seal	Urethane	2	
40	Cushion valve seal	NBR	2	
41	Cylinder tube gasket	NBR	2	
42	Bumper	Urethane	2	
43	Flat washer	Steel	8	Ø 80, Ø 100

Replacement Parts/Seal Kit

Bore size [mm]	Kit no.	Contents
32	C96N32W-PS	A set of 17 Rod seal A, 36 Rod seal B, 37 Rod seal C, 38 Piston seal B, 39 Cushion seal, and 41 Cylinder tube gasket
40	C96N40W-PS	
50	C96N50W-PS	
63	C96N63W-PS	
80	C96N80W-PS	
100	C96N100W-PS	

* Never disassemble the lock unit. It should be replaced as a unit. Refer to page 52 for the part numbers for placing an order. The seal kit shown above contains the rod seal for the cylinder and lock unit. Order the seal kit suitable for the cylinder bore size.

* The seal kit shown above includes a grease pack.
 (Ø 32, Ø 40, Ø 50: 10 g, Ø 63, Ø 80: 20 g, Ø 100: 30 g)
 Order with the following part number when only the grease pack is needed.
Grease pack part number: GR-S-010 (10 g), GR-S-020 (20 g)

Dimensions (Double Rod)

Basic: C96NB-W

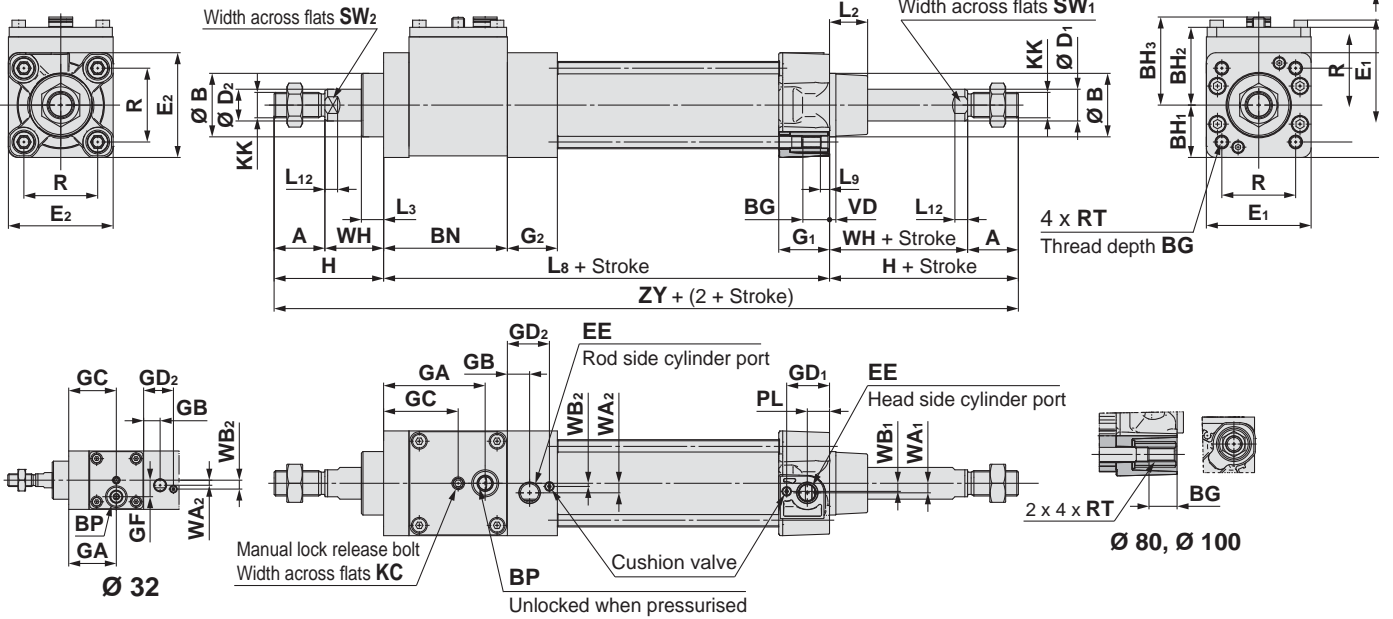

With rod boot

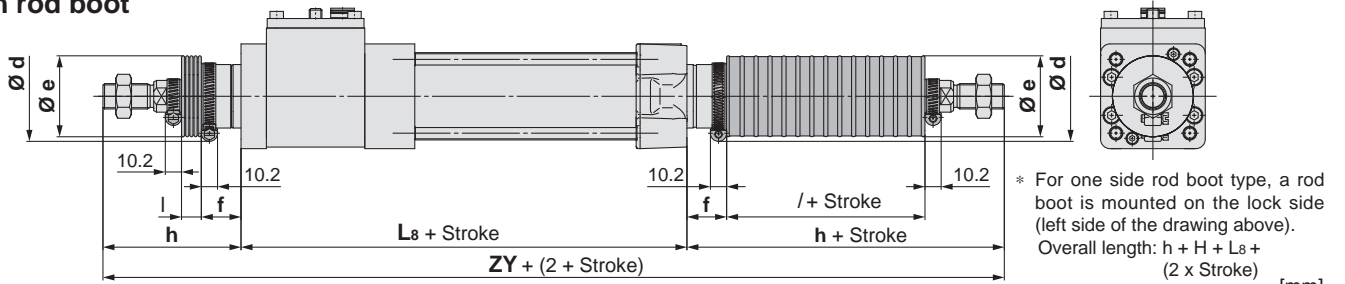

Bore size	Stroke range	A	Ø B _{d11}	BG	BH ₁	BH ₂	BH ₃	BN	BP	Ø D ₁	Ø D ₂	E ₁	E ₂	EE	G ₁	G ₂	GA	GB	GC	GD ₁	GD ₂	GF	H
32	Up to 1000	22	30	16	23	38.5	46.5	59	G1/8	12	12	46	47	G1/8	28.9	28.5	37.5	13	37.5	23.9	23.5	13	48
40	Up to 1000	24	35	16	28.5	42.5	48.5	73	G1/8	16	16	57	54	G1/4	32.6	29	59.5	14	44.5	27.6	24	—	54
50	Up to 1000	32	40	16	33	49	55.5	78	G1/8	20	20	66	66	G1/4	32	31.5	64	14	47	27	26.5	—	69
63	Up to 1000	32	45	16	39	52.5	59.5	90	G1/4	20	20	78	77	G3/8	38.6	31.5	73	16	53	31.6	26.5	—	69
80	Up to 1000	40	45	17	49	64.5	71.5	113	G1/4	25	25	98	99	G3/8	38.4	38	92	16	65	32	31.6	—	86
100	Up to 1000	40	55	17	58	73.5	80.5	131	G1/4	25	30	116	118	G1/2	42.9	38	109	18	74	36.5	31.6	—	91

Bore size	Stroke range	KC	KK	L ₂	L ₃	L ₈	L ₉	L ₁₂	PL	R	RT	SW ₁	SW ₂	V	VD	WA ₁	WA ₂	WB ₁	WB ₂	WH	ZY
32	Up to 1000	3	M10 x 1.25	15	13	152	4	13	13	32.5	M6 x 1	10	10	3.5	4	4	4	7	7	26	248
40	Up to 1000	3	M12 x 1.25	17	13	171	4	13	14	38	M6 x 1	13	13	4.5	4	5	7	8.9	1.8	30	279
50	Up to 1000	4	M16 x 1.5	24	14	181	5	14	14	46.5	M8 x 1.25	17	17	4.5	4	6	6	5.1	2	37	319
63	Up to 1000	4	M16 x 1.5	24	14	200.5	5	14	16	56.5	M8 x 1.25	17	17	5.5	4	9	9	6.3	2	37	338.5
80	Up to 1000	5	M20 x 1.5	30	20	238	—	20	16	72	M10 x 1.5	22	22	7.5	4	11.5	11.5	6	6	46	410
100	Up to 1000	5	M20 x 1.5	32	20	261.5	—	20	18	89	M10 x 1.5	22	26	9.5	4	17	17	10	3	51	443.5

With Rod Boot

Bore size	d	e	f	h																			
				1 to 50	51 to 100	101 to 150	151 to 200	201 to 300	301 to 400	401 to 500	501 to 600	601 to 700	701 to 800	801 to 900	901 to 1000								
32	54	36	23	75	88	100	113	138	163	188	213	238	263	288	313								
40	Lock unit side	56	41	23	75	88	100	113	138	163	188	213	238	263	288	313							
	Opposite side of the lock unit	54	36	23	75	88	100	113	138	163	188	213	238	263	288	313							
50	64	51	25	87	100	112	125	150	175	200	225	250	275	300	325								
63	64	51	25	87	100	112	125	150	175	200	225	250	275	300	325								
80	Lock unit side	68	56	29	103	116	128	141	166	191	216	241	266	291	316	341							
	Opposite side of the lock unit	76	61	29	103	116	128	141	166	191	216	241	266	291	316	341							
100	68	56	29	103	116	128	141	166	191	216	241	266	291	316	341								

Bore size	ZY																							
	1 to 50	51 to 100	101 to 150	151 to 200	201 to 300	301 to 400	401 to 500	501 to 600	601 to 700	701 to 800	801 to 900	901 to 1000												
32	12.5	25	37.5	50	75	100	125	150	175	200	225	250	302	328	352	378	428	478	528	578	628	678	728	778
40	12.5	25	37.5	50	75	100	125	150	175	200	225	250	321	347	371	397	447	497	547	597	647	697	747	797
50	12.5	25	37.5	50	75	100	125	150	175	200	225	250	355	381	405	431	481	531	581	631	681	731	781	831
63	12.5	25	37.5	50	75	100	125	150	175	200	225	250	374.5	400.5	424.5	450.5	500.5	550.5	600.5	650.5	700.5	750.5	800.5	850.5
80	12.5	25	37.5	50	75	100	125	150	175	200	225	250	444	470	494	520	570	620	670	720	770	820	870	920
100	12.5	25	37.5	50	75	100	125	150	175	200	225	250	467.5	493.5	517.5	543.5	593.5	643.5	693.5	743.5	793.5	843.5	893.5	943.5

C96N Series

Dimensions: With Mounting Bracket

* Refer to Basic (B) for other dimensions.

Axial foot: C96NL-W

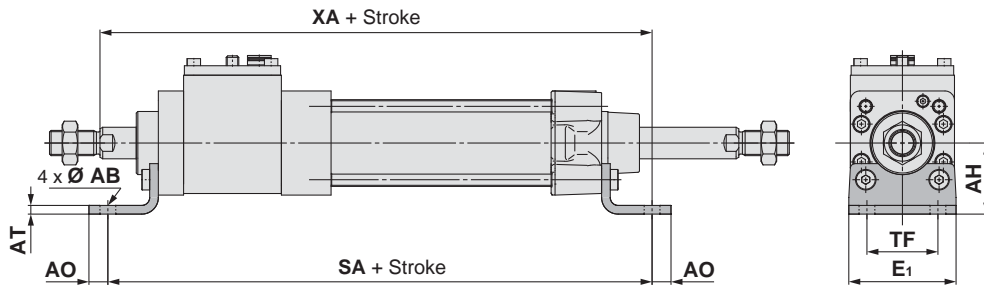

Bore size	AB	AH	AO	AT	E ₁	SA	TR	XA
32	7	32	10	4.5	48	200	32	202
40	10	36	11	4.5	55	227	36	229
50	10	45	12	5.5	68	245	45	250
63	10	50	12	5.5	80	264.5	50	269.5
80	12	63	14	6.5	100	320	63	325
100	14.5	71	16	6.5	120	343.5	75	353.5

Flange

Rod side: C96NF-W

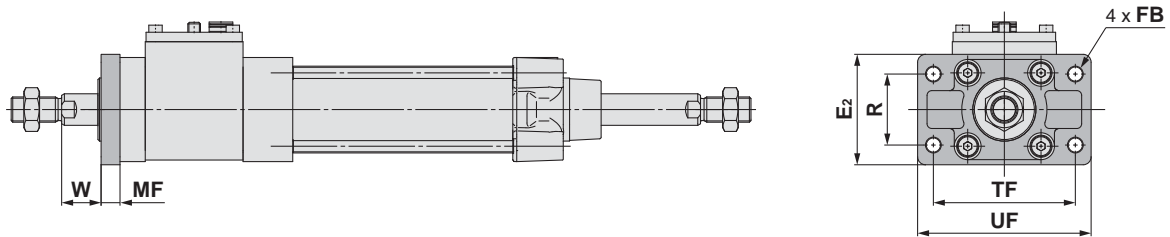

Head side: C96NG-W

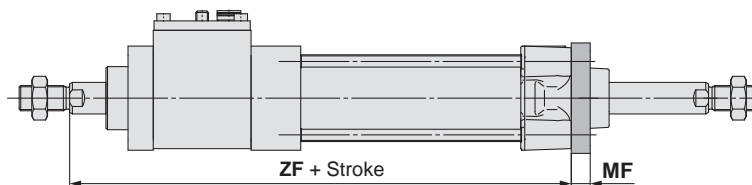

Bore size	E ₂	FB	MF	R	TF	UF	W	ZF
32	50	7	10	32	64	79	16	188
40	55	9	10	36	72	90	20	211
50	70	9	12	45	90	110	25	230
63	80	9	12	50	100	120	25	249.5
80	100	12	16	63	126	153	30	300
100	120	14	16	75	150	178	35	328.5

Centre trunnion: C96NT-W

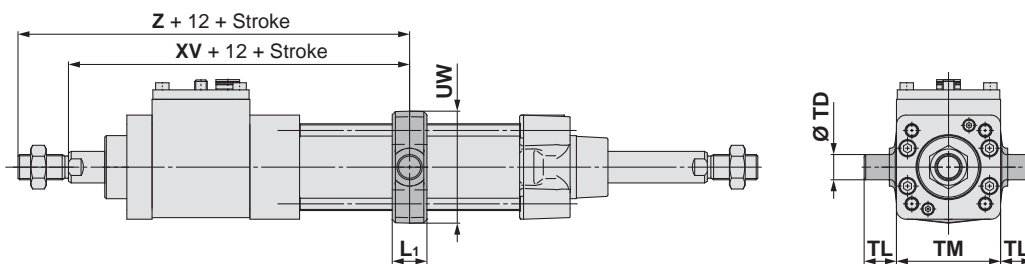

Bore size	L	TD _{e8}	TL	TM	UW	XV	Z
32	17	12	12	50	49	131	153
40	22	16	16	63	58	150	174
50	22	16	16	75	71	166	198
63	28	20	20	90	87	179	211
80	34	20	20	110	110	221	261
100	40	25	25	132	136	245	285

C96N Series Auto Switch Mounting

Auto Switch Proper Mounting Position (Detection at stroke end) and Mounting Height

<Tie-rod mounting>

D-M9□/M9□V D-Y59□/Y69□/Y7P/Y7PV
 D-M9□W/M9□WV D-Y7□W/Y7□WV/Y7BA
 D-M9□A/M9□AV D-Z7□/Z80
 D-A9□/A9□V

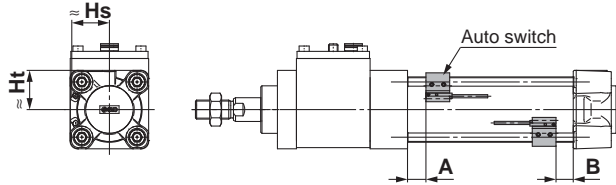

D-A5□/A6□
 D-A59W

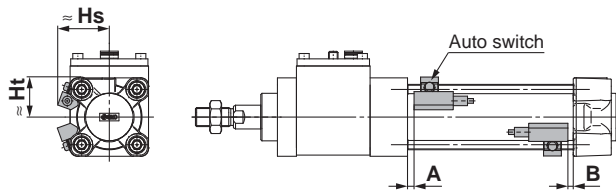

D-F5□/J5□
 D-F5□W/J59W/F5BA
 D-F59F/F5NT

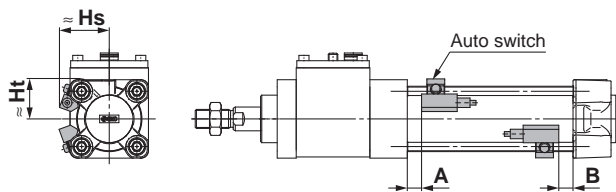

D-P3DWA

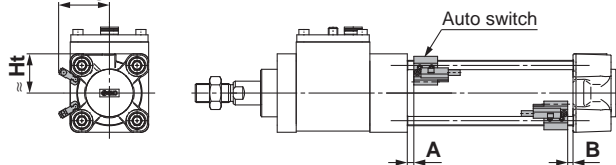

D-P4DW

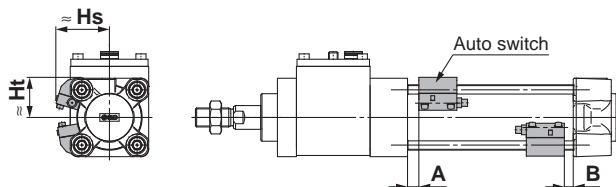

<Band mounting>

D-G39/K39/A3□

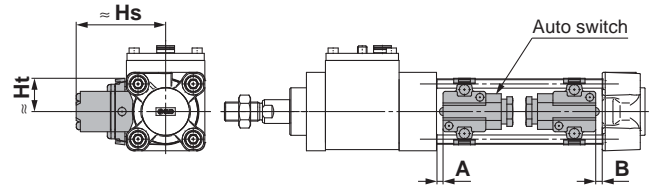

D-A44

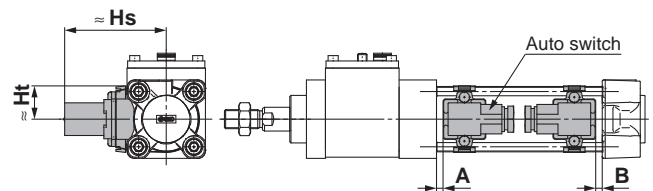

Model Selection

Working Principle

CP96N
 Double Acting, Single Rod

Double Acting, Double Rod

C96N

Double Acting, Single Rod

Double Acting, Double Rod

Lock Unit
 MWB-UT

Accessories

Auto Switch

Made to Order

Specific Product Precautions

C96N Series

Auto Switch Proper Mounting Position (Detection at stroke end) and Mounting Height

Auto Switch Proper Mounting Position

[mm]

Auto switch model	D-M9□ D-M9□V D-M9□W D-M9□WV D-M9□A D-M9□AV		D-A9□ D-A9□V		D-F5□ D-J59 D-F59F		D-F5NTL		D-A5□ D-A6□		D-A59W		D-G39 D-K39 D-A3□ D-A44		D-Y59□ D-Y69□ D-Y7P D-Y7PV D-Y7H D-Y7□W D-Y7□WV D-Y7BA D-Z7□ D-Z80		D-P3DWA		D-P4DW	
	A	B	A	B	A	B	A	B	A	B	A	B	A	B	A	B	A	B	A	B
32	13.5	10.5	9.5	6.5	10	7	15	12	3.5	0.5	7.5	4.5	3.5	0.5	7	4	9	6	6.5	3.5
40	10.5	14	6.5	10	7	10.5	12	15.5	0.5	4	4.5	8	0.5	4	4	7.5	6	9.5	3.5	7
50	13	14.5	9	10.5	9.5	11	14.5	16	3	4.5	7	8.5	3	4.5	6.5	8	8.5	10	6	7.5
63	13	15.5	9	11.5	9.5	12	14.5	17	3	5.5	7	9.5	3	5.5	6.5	9	8.5	11	6	8.5
80	18.5	18	14.5	14	15	14.5	20	19.5	8.5	8	12.5	12	8.5	8	12	11.5	14	13.5	11.5	11
100	18.5	19	14.5	15	15	15.5	20	20.5	8.5	9	12.5	13	8.5	9	12	12.5	14	14.5	11.5	12

* Adjust the auto switch after confirming the operating conditions in the actual setting.

Auto Switch Mounting Height

[mm]

Auto switch model	D-M9□ D-M9□W D-M9□A D-A9□		D-A9□V		D-M9□V D-M9□WV D-M9□AV		D-F5□ D-J59 D-F59F D-F5□W D-J59W D-F5BA D-F5NT		D-A5□ D-A6□ D-A59W		D-G39 D-K39 D-A3□		D-A44		D-Y59□ D-Y7P D-Y7□W D-Y7BA D-Z7□ D-Z80		D-Y69□ D-Y7PV D-Y7□WV		D-P3DWA		D-P4DW	
	Hs	Ht	Hs	Ht	Hs	Ht	Hs	Ht	Hs	Ht	Hs	Ht	Hs	Ht	Hs	Ht	Hs	Ht	Hs	Ht	Hs	Ht
32	24.5	23	27.5	23	30.5	23	32.5	25	35	24.5	67	27.5	77	27.5	25.5	23	26.5	23	38	31	38	31
40	28.5	25.5	31.5	25.5	34	25.5	36.5	27.5	38.5	27.5	71.5	27.5	81.5	27.5	29.5	26	30	26	39	25.5	42	33
50	33.5	31	36	31	38.5	31	41	34	43.5	34.5	77	—	87	—	33.5	31	34.5	31	43	31	46.5	39
63	38.5	36	40.5	36	43	36	46	39	48.5	39.5	83.5	—	93.5	—	39	36	40	36	48	36	51.5	44
80	46.5	45	49	45	52	45	52.5	46.5	55	46.5	92.5	—	103	—	47.5	45	48.5	45	56.5	45	58	51.5
100	54	53.5	57	53.5	59.5	53.5	59.5	55	62	55	103	—	113.5	—	55.5	53.5	56.5	53.5	64.5	53.5	65.5	60.5

Minimum Stroke for Auto Switch Mounting

Mounting Brackets except Centre Trunnion

n: Number of auto switches [mm]

Auto switch model	Number of auto switches	Ø 32	Ø 40	Ø 50	Ø 63	Ø 80	Ø 100
D-M9□ D-M9□W	2 (Different surfaces, same surface) 1	10					
	n	$10 + 40 \frac{(n-2)}{2}$ (n = 2, 4, 6, 8...)*1					
D-M9□V D-M9□WV	2 (Different surfaces, same surface) 1	10					
	n	$10 + 30 \frac{(n-2)}{2}$ (n = 2, 4, 6, 8...)*1					
D-M9□A	2 (Different surfaces, same surface) 1	15	10				
	n	$15 + 40 \frac{(n-2)}{2}$ (n = 2, 4, 6, 8...)*1	$10 + 40 \frac{(n-2)}{2}$ (n = 2, 4, 6, 8...)*1				
D-M9□AV	2 (Different surfaces, same surface) 1	10					
	n	$10 + 30 \frac{(n-2)}{2}$ (n = 2, 4, 6, 8...)*1					
D-A9□	2 (Different surfaces, same surface) 1	10					
	n	$10 + 40 \frac{(n-2)}{2}$ (n = 2, 4, 6, 8...)*1					
D-A9□V	2 (Different surfaces, same surface) 1	10					
	n	$10 + 30 \frac{(n-2)}{2}$ (n = 2, 4, 6, 8...)*1					
D-G39 D-K39 D-A3□	2 (Different surfaces)	35					
	2 (Same surface)	100					
	n (Different surfaces)	$35 + 30(n-2)$ (n = 2, 3, 4...)					
	n (Same surface)	$100 + 100(n-2)$ (n = 2, 3, 4...)					
D-A44	2 (Different surfaces)	35					
	2 (Same surface)	50					
	n (Different surfaces)	$35 + 30(n-2)$ (n = 2, 3, 4...)					
	n (Same surface)	$50 + 50(n-2)$ (n = 2, 3, 4...)					
D-F5□ D-J59 D-F5□W D-J59W D-F5BA D-F59F	2 (Different surfaces, same surface) 1	15					
	n	$15 + 55 \frac{(n-2)}{2}$ (n = 2, 4, 6, 8...)*1					
D-A5□ D-A6□	2 (Different surfaces, same surface) 1	15				10	
	n	$15 + 55 \frac{(n-2)}{2}$ (n = 2, 4, 6, 8...)*1				$10 + 55 \frac{(n-2)}{2}$ (n = 2, 4, 6, 8...)*1	
D-A59W	2 (Different surfaces, same surface) 1	20			15		
	n	$20 + 55 \frac{(n-2)}{2}$ (n = 2, 4, 6, 8...)*1			$15 + 55 \frac{(n-2)}{2}$ (n = 2, 4, 6, 8...)*1		
D-F5NTL	2 (Different surfaces, same surface) 1	25				20	
	n	$25 + 55 \frac{(n-2)}{2}$ (n = 2, 4, 6, 8...)*1				$20 + 55 \frac{(n-2)}{2}$ (n = 2, 4, 6, 8...)*1	
D-Y59□ D-Y7P D-Z7□ D-Z80	2 (Different surfaces, same surface) 1	15	10				
	n	$15 + 40 \frac{(n-2)}{2}$ (n = 2, 4, 6, 8...)*1	$10 + 40 \frac{(n-2)}{2}$ (n = 2, 4, 6, 8...)*1				

*1 When "n" is an odd number, an even number that is one larger than the odd number is to be used for the calculation.

Model Selection

Working Principle

CP96N

Double Acting, Single Rod

Double Acting, Double Rod

C96N

Double Acting, Single Rod

Double Acting, Double Rod

Lock Unit MWB-UT

Accessories

Auto Switch

Made to Order

Specific Product Precautions

C96N Series

Minimum Stroke for Auto Switch Mounting

Mounting Brackets except Centre Trunnion

n: Number of auto switches [mm]

Auto switch model	Number of auto switches	Ø 32	Ø 40	Ø 50	Ø 63	Ø 80	Ø 100
D-Y69 D-Y7PV D-Y7□WV	2 (Different surfaces, same surface) 1	10					
	n	$10 + 30 \frac{(n-2)}{2}$ (n = 2, 4, 6, 8...)*1					
D-Y7BA	2 (Different surfaces, same surface) 1	20					
	n	$20 + 45 \frac{(n-2)}{2}$ (n = 2, 4, 6, 8...)*1					
D-P3DWA	2 (Different surfaces, same surface) 1	15					
	n (Different surfaces, same surface)	$15 + 50 \frac{(n-2)}{2}$ (n = 2, 4, 6, 8...)*1					
D-P4DW	2 (Different surfaces, same surface) 1	15					
	n	$15 + 65 \frac{(n-2)}{2}$ (n = 2, 4, 6, 8...)*1					

*1 When "n" is an odd number, an even number that is one larger than the odd number is to be used for the calculation.

Centre Trunnion

n: Number of auto switches [mm]

Auto switch model	Number of auto switches	Ø 32	Ø 40	Ø 50	Ø 63	Ø 80	Ø 100
D-M9□ D-M9□W	2 (Different surfaces, same surface) 1	75			85	90	95
	n	$75 + 40 \frac{(n-4)}{2}$ (n = 4, 8, 12, 16...)*2			$85 + 40 \frac{(n-4)}{2}$ (n = 4, 8, 12, 16...)*2	$90 + 40 \frac{(n-4)}{2}$ (n = 4, 8, 12, 16...)*2	$95 + 40 \frac{(n-4)}{2}$ (n = 4, 8, 12, 16...)*2
D-M9□V D-M9□WV	2 (Different surfaces, same surface) 1	50	55		60	65	70
	n	$50 + 30 \frac{(n-4)}{2}$ (n = 4, 8, 12, 16...)*2	$55 + 30 \frac{(n-4)}{2}$ (n = 4, 8, 12, 16...)*2		$60 + 30 \frac{(n-4)}{2}$ (n = 4, 8, 12, 16...)*2	$65 + 30 \frac{(n-4)}{2}$ (n = 4, 8, 12, 16...)*2	$70 + 30 \frac{(n-4)}{2}$ (n = 4, 8, 12, 16...)*2
D-M9□A	2 (Different surfaces, same surface) 1	80			85	95	100
	n	$80 + 40 \frac{(n-4)}{2}$ (n = 4, 8, 12, 16...)*2			$85 + 40 \frac{(n-4)}{2}$ (n = 4, 8, 12, 16...)*2	$95 + 40 \frac{(n-4)}{2}$ (n = 4, 8, 12, 16...)*2	$100 + 40 \frac{(n-4)}{2}$ (n = 4, 8, 12, 16...)*2
D-M9□AV	2 (Different surfaces, same surface) 1	55			65	70	75
	n	$55 + 30 \frac{(n-4)}{2}$ (n = 4, 8, 12, 16...)*2			$65 + 30 \frac{(n-4)}{2}$ (n = 4, 8, 12, 16...)*2	$70 + 30 \frac{(n-4)}{2}$ (n = 4, 8, 12, 16...)*2	$75 + 30 \frac{(n-4)}{2}$ (n = 4, 8, 12, 16...)*2
D-A9□	2 (Different surfaces, same surface) 1	70	75		80	85	90
	n	$70 + 40 \frac{(n-4)}{2}$ (n = 4, 8, 12, 16...)*2	$75 + 40 \frac{(n-4)}{2}$ (n = 4, 8, 12, 16...)*2		$80 + 40 \frac{(n-4)}{2}$ (n = 4, 8, 12, 16...)*2	$85 + 40 \frac{(n-4)}{2}$ (n = 4, 8, 12, 16...)*2	$90 + 40 \frac{(n-4)}{2}$ (n = 4, 8, 12, 16...)*2
D-A9□V	2 (Different surfaces, same surface) 1	45	50		55	60	70
	n	$45 + 30 \frac{(n-4)}{2}$ (n = 4, 8, 12, 16...)*2	$50 + 30 \frac{(n-4)}{2}$ (n = 4, 8, 12, 16...)*2		$55 + 30 \frac{(n-4)}{2}$ (n = 4, 8, 12, 16...)*2	$60 + 30 \frac{(n-4)}{2}$ (n = 4, 8, 12, 16...)*2	$70 + 30 \frac{(n-4)}{2}$ (n = 4, 8, 12, 16...)*2

*2 When "n" is an odd number, a multiple of 4 that is larger than the odd number is to be used for the calculation.

Minimum Stroke for Auto Switch Mounting

Centre Trunnion

n: Number of auto switches [mm]

Auto switch model	Number of auto switches	Ø 32	Ø 40	Ø 50	Ø 63	Ø 80	Ø 100
D-G39 D-K39 D-A3□	2 (Different surfaces)	60	65		75	80	85
	2 (Same surface)	90	95		100	105	110
	n (Different surfaces)	$60 + 30(n - 2)$ (n = 2, 4, 6, 8...)*1	$65 + 30(n - 2)$ (n = 2, 4, 6, 8...)*1		$75 + 30(n - 2)$ (n = 2, 4, 6, 8...)*1	$80 + 30(n - 2)$ (n = 2, 4, 6, 8...)*1	$85 + 30(n - 2)$ (n = 2, 4, 6, 8...)*1
	n (Same surface)	$90 + 100(n - 2)$ (n = 2, 4, 6, 8...)*1	$95 + 100(n - 2)$ (n = 2, 4, 6, 8...)*1		$100 + 100(n - 2)$ (n = 2, 4, 6, 8...)*1	$105 + 100(n - 2)$ (n = 2, 4, 6, 8...)*1	$110 + 100(n - 2)$ (n = 2, 4, 6, 8...)*1
	1	60	65		75	80	85
D-A44	2 (Different surfaces)	70			75	80	85
	2 (Same surface)	70			75	80	85
	n (Different surfaces)	$70 + 30(n - 2)$ (n = 2, 4, 6, 8...)*1			$75 + 30(n - 2)$ (n = 2, 4, 6, 8...)*1	$80 + 30(n - 2)$ (n = 2, 4, 6, 8...)*1	$85 + 30(n - 2)$ (n = 2, 4, 6, 8...)*1
	n (Same surface)	$70 + 50(n - 2)$ (n = 2, 4, 6, 8...)*1			$75 + 50(n - 2)$ (n = 2, 4, 6, 8...)*1	$80 + 50(n - 2)$ (n = 2, 4, 6, 8...)*1	$85 + 50(n - 2)$ (n = 2, 4, 6, 8...)*1
	1	70			75	80	85
D-F5□ D-J59 D-F5□W D-J59W D-F5BA D-F59F	2 (Different surfaces, same surface)	90	95		100	110	115
	1						
	n	$90 + 55 \frac{(n - 4)}{2}$ (n = 4, 8, 12, 16...)*2	$95 + 55 \frac{(n - 4)}{2}$ (n = 4, 8, 12, 16...)*2		$100 + 55 \frac{(n - 4)}{2}$ (n = 4, 8, 12, 16...)*2	$110 + 55 \frac{(n - 4)}{2}$ (n = 4, 8, 12, 16...)*2	$115 + 55 \frac{(n - 4)}{2}$ (n = 4, 8, 12, 16...)*2
D-A5□ D-A6□	2 (Different surfaces, same surface)	75	80		95	105	110
	1						
	n	$75 + 55 \frac{(n - 4)}{2}$ (n = 4, 8, 12, 16...)*2	$80 + 55 \frac{(n - 4)}{2}$ (n = 4, 8, 12, 16...)*2		$95 + 55 \frac{(n - 4)}{2}$ (n = 4, 8, 12, 16...)*2	$105 + 55 \frac{(n - 4)}{2}$ (n = 4, 8, 12, 16...)*2	$110 + 55 \frac{(n - 4)}{2}$ (n = 4, 8, 12, 16...)*2
D-A59W	2 (Different surfaces, same surface)	85			105	110	115
	1						
	n	$85 + 55 \frac{(n - 4)}{2}$ (n = 4, 8, 12, 16...)*2			$105 + 55 \frac{(n - 4)}{2}$ (n = 4, 8, 12, 16...)*2	$110 + 55 \frac{(n - 4)}{2}$ (n = 4, 8, 12, 16...)*2	$115 + 55 \frac{(n - 4)}{2}$ (n = 4, 8, 12, 16...)*2
D-F5NTL	2 (Different surfaces, same surface)	100	105		110	120	125
	1						
	n	$100 + 55 \frac{(n - 4)}{2}$ (n = 4, 8, 12, 16...)*2	$105 + 55 \frac{(n - 4)}{2}$ (n = 4, 8, 12, 16...)*2		$110 + 55 \frac{(n - 4)}{2}$ (n = 4, 8, 12, 16...)*2	$120 + 55 \frac{(n - 4)}{2}$ (n = 4, 8, 12, 16...)*2	$125 + 55 \frac{(n - 4)}{2}$ (n = 4, 8, 12, 16...)*2
D-Y59□ D-Y7P D-Y7□W D-Z7□ D-Z80	2 (Different surfaces, same surface)	75	80		85	95	100
	1						
	n	$75 + 40 \frac{(n - 4)}{2}$ (n = 4, 8, 12, 16...)*2	$80 + 40 \frac{(n - 4)}{2}$ (n = 4, 8, 12, 16...)*2		$85 + 40 \frac{(n - 4)}{2}$ (n = 4, 8, 12, 16...)*2	$95 + 40 \frac{(n - 4)}{2}$ (n = 4, 8, 12, 16...)*2	$100 + 40 \frac{(n - 4)}{2}$ (n = 4, 8, 12, 16...)*2
D-Y69 D-Y7PV D-Y7□WV	2 (Different surfaces, same surface)	55			60	70	75
	1						
	n	$55 + 30 \frac{(n - 4)}{2}$ (n = 4, 8, 12, 16...)*2			$60 + 30 \frac{(n - 4)}{2}$ (n = 4, 8, 12, 16...)*2	$70 + 30 \frac{(n - 4)}{2}$ (n = 4, 8, 12, 16...)*2	$75 + 30 \frac{(n - 4)}{2}$ (n = 4, 8, 12, 16...)*2
D-Y7BA	2 (Different surfaces, same surface)	85	90		100	105	110
	1						
	n	$85 + 45 \frac{(n - 4)}{2}$ (n = 4, 8, 12, 16...)*2	$90 + 45 \frac{(n - 4)}{2}$ (n = 4, 8, 12, 16...)*2		$100 + 45 \frac{(n - 4)}{2}$ (n = 4, 8, 12, 16...)*2	$105 + 45 \frac{(n - 4)}{2}$ (n = 4, 8, 12, 16...)*2	$110 + 45 \frac{(n - 4)}{2}$ (n = 4, 8, 12, 16...)*2
D-P3DWA	2 (Different surfaces, same surface)	90	95		100	105	110
	1						
	n (Different surfaces, same surface)	$90 + 50 \frac{(n - 4)}{2}$ (n = 4, 8, 12, 16...)*2	$95 + 50 \frac{(n - 4)}{2}$ (n = 4, 8, 12, 16...)*2		$100 + 50 \frac{(n - 4)}{2}$ (n = 4, 8, 12, 16...)*2	$105 + 50 \frac{(n - 4)}{2}$ (n = 4, 8, 12, 16...)*2	$110 + 50 \frac{(n - 4)}{2}$ (n = 4, 8, 12, 16...)*2
D-P4DW	2 (Different surfaces, same surface)	110			115	125	130
	1						
	n	$110 + 65 \frac{(n - 4)}{2}$ (n = 4, 8, 12, 16...)*2			$115 + 65 \frac{(n - 4)}{2}$ (n = 4, 8, 12, 16...)*2	$125 + 65 \frac{(n - 4)}{2}$ (n = 4, 8, 12, 16...)*2	$130 + 65 \frac{(n - 4)}{2}$ (n = 4, 8, 12, 16...)*2

*1 When "n" is an odd number, an even number that is one larger than the odd number is to be used for the calculation.

*2 When "n" is an odd number, a multiple of 4 that is larger than the odd number is to be used for the calculation.

Model Selection

Working Principle

CP96N

Double Acting, Single Rod

Double Acting, Double Rod

C96N

Double Acting, Single Rod

Double Acting, Double Rod

Lock Unit MWB-UT

Accessories

Auto Switch

Made to Order

Specific Product Precautions

C96N Series

Auto Switch Mounting Brackets/Part Nos.

Auto switch model	Bore size [mm]					
	32	40	50	63	80	100
D-M9□/M9□V D-M9□W/M9□WV D-M9□A/M9□AV D-A9□/A9□V	BMB5-032	BMB5-032	BA7-040	BA7-040	BA7-063	BA7-063
D-A3□/A44 D-G39/K39	BMB2-032	BMB2-040	BMB1-050	BMB1-063	BMB1-080	BMB1-100
D-F5□/J59 D-F5□W/J59W D-F59F/F5BA D-F5NT D-A5□/A6□/A59W	BT-03	BT-03	BT-05	BT-05	BT-06	BT-06
D-P3DWA	BA10-032S	BA10-040S	BA10-050S	BA10-050S	BA10-063S	BA10-063S
D-P4DW	BMB3T-040	BMB3T-040	BMB3T-050	BMB3T-050	BMB3T-080	BMB3T-080
D-Y59□/Y69□ D-Y7P/Y7PV D-Y7□W/Y7□WV D-Y7BA D-Z7□/Z80	BMB4-032	BMB4-032	BMB4-050	BMB4-050	BA4-063	BA4-063

[Stainless Steel Mounting Screw]

The following stainless steel mounting screw kit (including set screws) is available. Use it in accordance with the operating environment. (Since the auto switch mounting bracket is not included, order it separately.)

BBA1: For D-A5/A6/F5/J5 types

* Refer to the **Web Catalogue** for details on the BBA1.

The above stainless steel screws are used when a cylinder is shipped with the D-F5BA auto switch. When only one auto switch is shipped independently, the BBA1 is attached.

* When using the D-M9□A(V) or Y7BA, do not use the steel set screws which are included with the auto switch mounting brackets above (BMB5-032, BA7-□□□, BMB4-□□□, BA4-□□□).

Order a stainless steel screw kit (BBA1) separately, and use the M4 x 6 L stainless steel set screws included in the BBA1.

· The figure shows the mounting example for the D-M9□(V)/M9□W(V)/M9□A(V)/A9□(V).

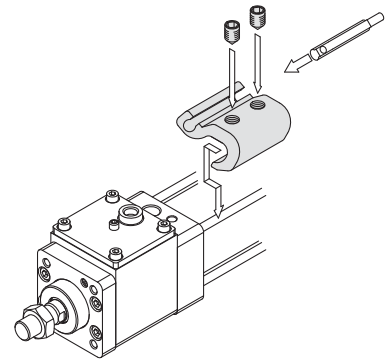

Operating Range

Auto switch model	Bore size [mm]					
	32	40	50	63	80	100
D-M9□/M9□V D-M9□W/M9□WV D-M9□A/M9□AV	4	4.5	4.5	4.5	5	6
D-Y59□/Y69□ D-Y7P/Y7□V D-Y7□W/Y7□WV D-Y7BA	5.5	5.5	7	7.5	6.5	5.5
D-F5□/J59 D-F5□W/J59W D-F5BA/F5NT D-F59F	3.5	4	4	4.5	4.5	4.5
D-G39/K39	9	9	9	10	10	11
D-P3DWA	3	4.5	4.5	5	5	5.5
D-P4DW	4	4	4	4.5	4	4.5
D-A9□/A9□V	7	7.5	8.5	9.5	9.5	10.5
D-Z7□/Z80	7.5	8.5	7.5	9.5	9.5	10.5
D-A5□/A6□	9	9	10	11	11	11
D-A59W	13	13	13	14	14	15
D-A3□/A44	9	9	10	11	11	11

* Values which include hysteresis are for reference purposes only. They are not a guarantee (assuming approximately ± 3 0 % dispersion) and may change substantially depending on the ambient environment.

<Mounting example for Ø 32, D-P3DWA>

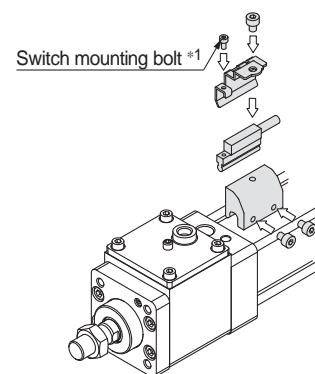

*1 The switch mounting bolt is supplied with the switch.

Other than the applicable auto switches listed in “How to Order,” the following auto switches are also mountable.

Refer to the **Web Catalogue** for the detailed specifications.

Type	Model	Electrical entry	Features
Solid state	D-Y69A, Y69B, Y7PV	Grommet (Perpendicular)	—
	D-Y7NWV, Y7PWV, Y7BWW		Diagnostic indication (2-colour indicator)
	D-F59, F5P, J59	Grommet (In-line)	—
	D-Y59A, Y59B, Y7P		
	D-Y7H		
	D-F59W, F5PW, J59W		
	D-Y7NW, Y7PW, Y7BW		
	D-F5BA, Y7BA		
	D-F5NT		
	D-P5DW		
Reed	D-A53, A56, Z73, Z76	Grommet (In-line)	—
	D-A67, Z80		Without indicator light

* With pre-wired connector is also available for solid state switches. For details, refer to the **Web Catalogue**.

* Normally closed (NC = b contact) solid state auto switches (D-M9□E, Y7G, Y7H) are also available. For details, refer to the **Web Catalogue**.

Model Selection

Working Principle

CP96N

Double Acting, Single Rod

Double Acting, Double Rod

C96N

Double Acting, Single Rod

Double Acting, Double Rod

Lock Unit **MWB-UT**

Accessories

Auto Switch

Made to Order

Specific Product Precautions

Lock Unit

MWB-UT Series

32, 40, 50, 63, 80, 100

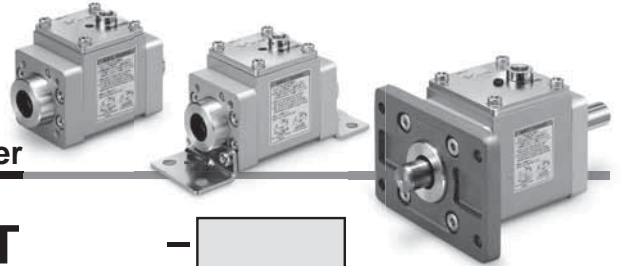

How to Order

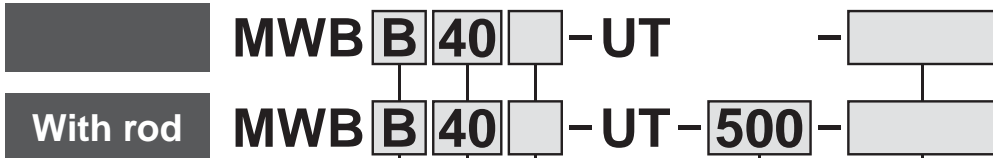

Mounting

B	Basic
L	Axial foot
F	Flange

* Mounting bracket is shipped together with the product.

Model

Model	Applicable rod size
32	12 mm
40	16 mm
50	20 mm
63	20 mm
80	25 mm
100	30 mm

Port thread type

—	Rc
TN	NPT
TF	G

Made to order

XC35	With coil scraper
XC68	Made of stainless steel

Refer to page 48 for details.

Rod length [mm]

—		Without accessory rod	
Min. length	Max. length	Applicable model	Note
250	2500*1	32	Can be manufactured in increments of 1 mm up to the maximum length.
300		40	
		50	
		63	
		80	
		100	

*1 The maximum rod length of the MWB□32-XC68 is 1800 mm.

* The rod length indicates the overall length of the rod.

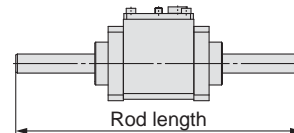

* Rod is shipped together with the product.

Specifications

Model	32	40	50	63	80	100
Applicable rod size [mm]*2	∅ 12 f8	∅ 16 f8	∅ 20 f8	∅ 20 f8	∅ 25 f8	∅ 30 f8
Locking action	Exhaust locking					
Proof pressure	1.5 MPa					
Max. operating pressure	1.0 MPa					
Min. operating pressure	0.3 MPa					
Locking direction	Both directions					
Holding force (Max. static load) [N]*1	630	980	1570	2450	3920	6080
Stopping accuracy [mm]	±1.0					

*1 The holding force (max. static load) shows the maximum capability and does not show the normal holding capability. Refer to pages 6 and 7 to select an appropriate lock unit.

*2 The applicable rod size affects the holding force, so use a rod with the rod size tolerance shown in the table above. For the shape of the rod end to be inserted, refer to page 54.

Weight

Model		32	40	50	63	80	100
Basic weight	Lock unit	0.59	1.09	1.51	2.32	4.41	7.00
Mounting bracket weight (including bracket mounting bolts)	Foot bracket (2 pcs.)	0.12	0.14	0.22	0.26	0.50	0.66
	Flange	0.24	0.32	0.53	0.74	1.45	3.31
Additional rod weight per 50 mm		0.04	0.08	0.12	0.12	0.19	0.27

Calculation example)

MWBL40-UT-500 (Axial foot, Model 40, With a 500 mm rod)

- Basic weight1.09 (Lock unit, Model 40)
- Additional weight0.08/50 mm
- Rod length500 mm
- Axial foot.....0.14

$$1.09 + (0.08/50) \times 500 + 0.14 = 2.03 \text{ kg}$$

Construction

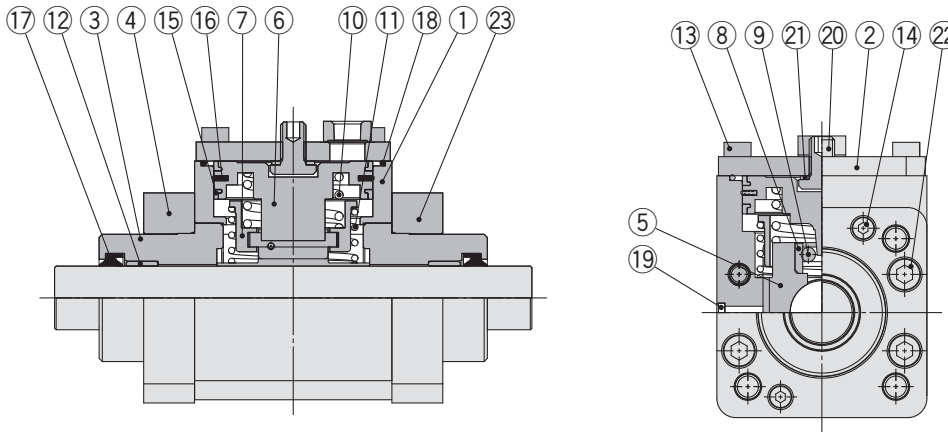

Component Parts

No.	Description	Material	Qty.	Note
1	Brake unit	Aluminium alloy	1	Hard anodised
2	Cap	Rolled steel	1	Zinc chromated
3	Collar	Aluminium alloy	2	Chromated
4	Retaining plate	Aluminium alloy	1	Anodised
5	Brake pad	Cast iron	1	
6	Piston A	Aluminium alloy	1	
7	Roller holder	Carbon steel	1	
8	Roller receiver	Stainless steel	2	Heat treated
9	Needle roller	Carbon steel	2	Heat treated
10	Piston spring	Spring steel	1	Zinc chromated
11	Roller spring	Spring steel	1	Zinc chromated
12	Bushing	Bearing alloy	2	

No.	Description	Material	Qty.	Note
13	Hexagon socket head cap screw	Alloy steel	4	
14	Hexagon socket head cap screw	Alloy steel	2	
15	Wear ring	Resin	2	
16	Piston seal	NBR	1	
17	Rod seal	NBR	2	
18	Gasket	NBR	1	
19	Element	Bronze	1	
20	Release bolt	Alloy steel	1	
21	Seal washer	NBR + Stainless steel	1	
22	Hexagon socket head cap screw	Alloy steel	4	
23	Unit cover	Aluminium alloy	1	

* The lock unit cannot be disassembled.

Model Selection

Working Principle

CP96N

Double Acting, Single Rod

Double Acting, Double Rod

C96N

Double Acting, Single Rod

Double Acting, Double Rod

Lock Unit MWB-UT

Accessories

Auto Switch

Made to Order

Specific Product Precautions

MWB-UT Series

Dimensions

Basic: MWBB□-UT-□

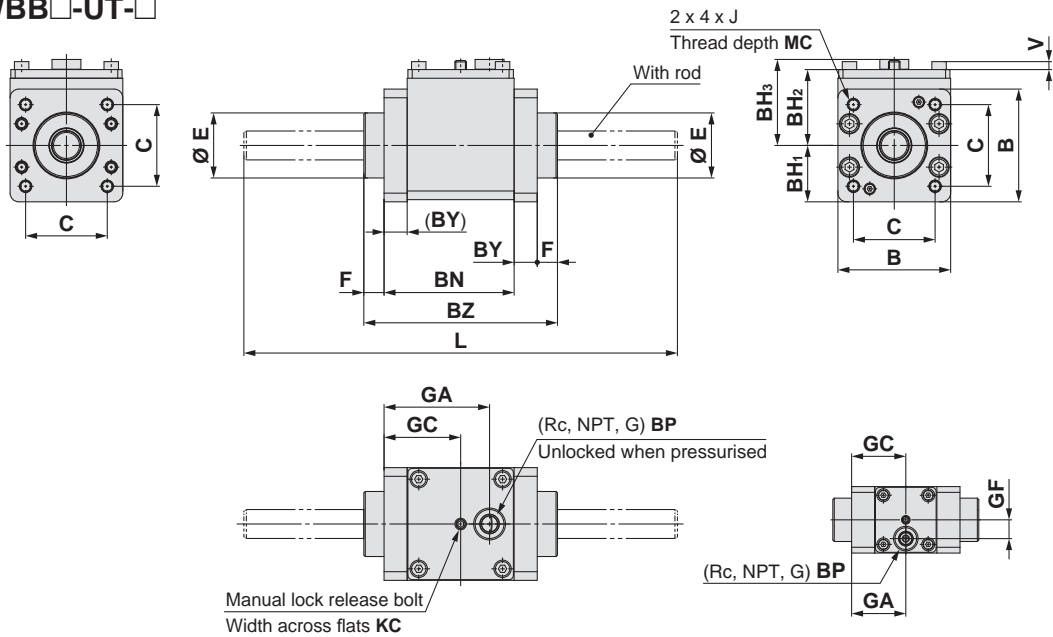

Model	Applicable rod size	B	BH ₁	BH ₂	BH ₃	BN	BP	BY	BZ	C	E	F	GA	GC	GF	J	KC	MC	V
32	Ø 12 f8	46	23	38.5	46.5	59	1/8	16	101	32.5	30	13	37.5	37.5	13	M6 x 1.0	3	16	3.5
40	Ø 16 f8	57	28.5	42.5	48.5	73	1/8	16	115	38	35	13	59.5	44.5	—	M6 x 1.0	3	16	4.5
50	Ø 20 f8	66	33	49	55.5	78	1/8	16	122	46.5	40	14	64	47	—	M8 x 1.25	4	16	4.5
63	Ø 20 f8	78	39	52.5	59.5	90	1/4	16	134	56.5	45	14	73	53	—	M8 x 1.25	4	16	5.5
80	Ø 25 f8	98	49	64.5	71.5	113	1/4	17	170	72	45	20	92	65	—	M10 x 1.5	5	17	7.5
100	Ø 30 f8	116	58	73.5	80.5	131	1/4	17	188	89	55	20	109	74	—	M10 x 1.5	5	17	9.5

With Rod [mm]

Model	L	
	Min. length	Max. length
32	250	2500*1
40	250	
50	300	
63	300	
80	300	
100	300	

*1 The maximum rod length of the MWB□32-XC68 is 1800 mm.

Axial foot: MWBL□-UT-□

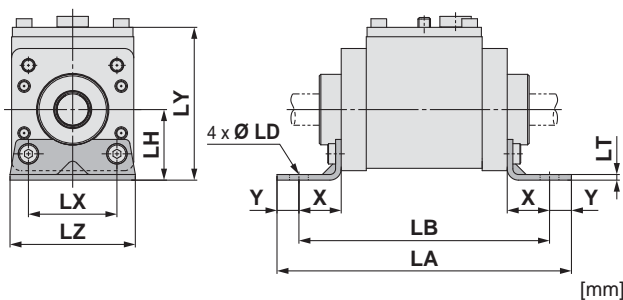

Model	LA	LB	LD	LH	LT	LX	LY	LZ	X	Y
32	137	119	7	30	3.2	32	68.5	50	22	9
40	159	137	9	33	3.2	38	75.5	55	24	11
50	170	148	9	40	3.2	46	89	70	27	11
63	188	160	12	48	3.6	56	100.5	80	27	14
80	218	190	12	55	4.5	72	119.5	100	30	14
100	244	212	14	65	4.5	89	138.5	120	32	16

Flange: MWBF□-UT-□

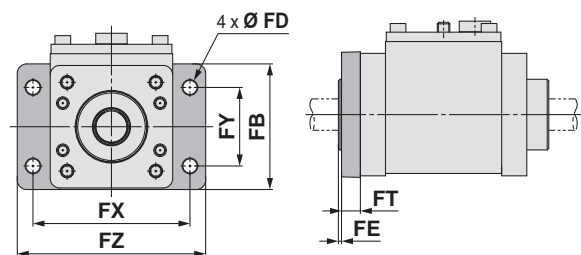

Model	FB	FD	FE	FT	FX	FY	FZ
32	56	7	3	10	72	38	87
40	65	9	3	10	83	46	101
50	77	9	2	12	100	52	120
63	92	9	2	12	115	62	135
80	100	12	4	16	126	63	153
100	120	14	4	16	150	75	178

CP96N/C96N Series Simple Specials

The following changes are dealt with through the Simple Specials System.

Please contact your local sales representative for more details.

1 Change of Rod End Shape

Symbol
-XA0 to XA30

Series		Action	Symbol for change of rod end shape	Note
Standard	CP96N C96N	Double acting, Single rod	XA0 to 30	Excludes cylinders with a rod end bracket

Precautions

- SMC will make appropriate arrangements if no dimension, tolerance, or finish instructions are given in the diagram.
- Standard dimensions marked with "*" will be as follows to the rod diameter (D). Enter any special dimension you require.

- "A0" is the same shape as the standard type. (The specifications of A0 are that only dimensions A and H are changed from the standard type.)

Symbol: A0 	Symbol: A1 	Symbol: A2 	Symbol: A3
Symbol: A4 	Symbol: A5 	Symbol: A6 	Symbol: A7
Symbol: A8 	Symbol: A9 	Symbol: A10 	Symbol: A11
Symbol: A12 	Symbol: A13 	Symbol: A14 	Symbol: A15
Symbol: A16 	Symbol: A17 	Symbol: A18 	Symbol: A19

Model
Selection

Working
Principle

CP96N

Double Acting,
Single Rod

Double Acting,
Double Rod

C96N

Double Acting,
Single Rod

Double Acting,
Double Rod

Lock Unit
MWB-UT

Accessories

Auto Switch

Made to
Order

Specific Product
Precautions

CP96N/C96N Series

1 Change of Rod End Shape

Symbol
-XA0 to XA30

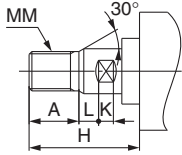
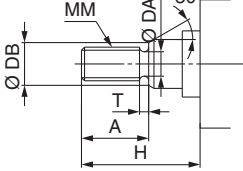
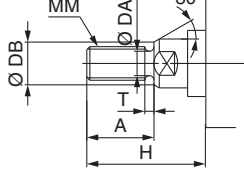
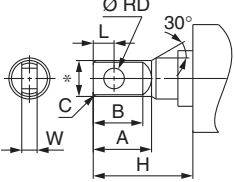
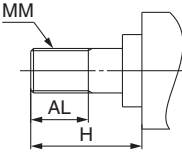
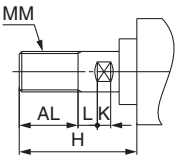
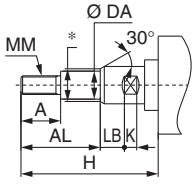
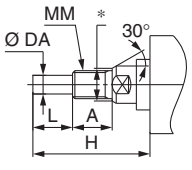
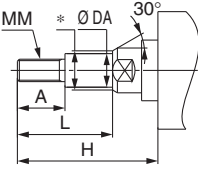
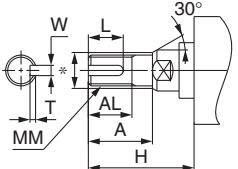
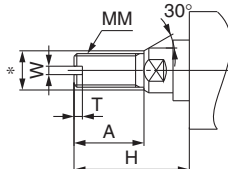
<p>Symbol: A20</p> 	<p>Symbol: A21</p> 	<p>Symbol: A22</p> 	<p>Symbol: A23</p> 
<p>Symbol: A24</p> 	<p>Symbol: A25</p> 	<p>Symbol: A26</p> 	<p>Symbol: A27</p> 
<p>Symbol: A28</p> 	<p>Symbol: A29</p> 	<p>Symbol: A30</p> 	

Made to Order Common Specifications

Please contact SMC for detailed dimensions, specifications, and delivery times.

1 With Coil Scraper Symbol -XC35

Removes frost, ice, weld spatter, cutting chips, etc. adhered to the piston rod, protecting the seals.

Applicable Series

Description	Model	Action	Note
Standard	CP96N	Double acting, Single rod/Double rod	—
	C96N	Double acting, Single rod/Double rod	—
	MWB-UT	—	Lock unit

How to Order

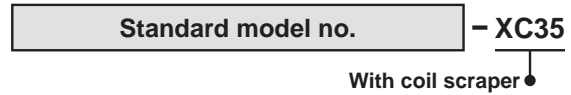

Specifications and dimensions: Same as the standard type

Construction

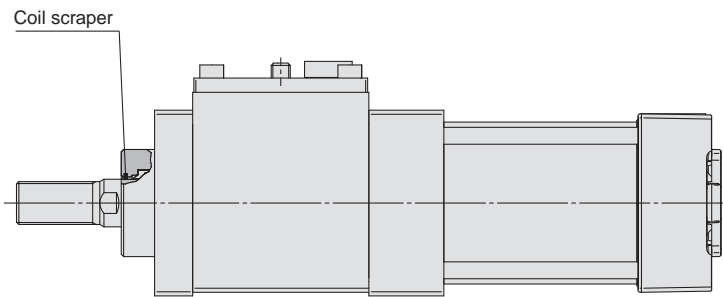

Cylinder with lock

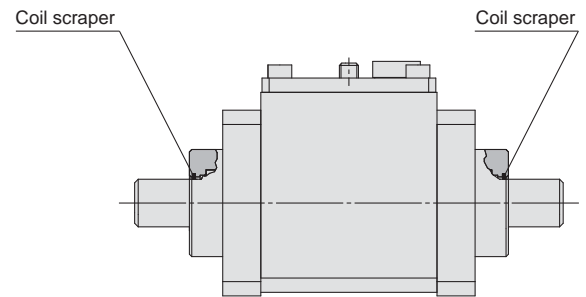

Lock unit

2 Made of Stainless Steel (For Lock Unit, With Hard Chrome Plating) Symbol -XC68

Suitable for environments where rust and corrosion are likely to be generated.

Applicable Series

Description	Model	Note
Standard	MWB-UT	Lock unit

How to Order

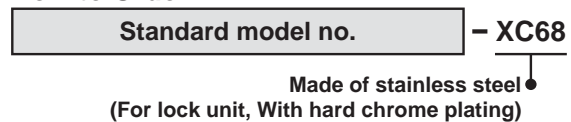

Specifications and dimensions: Same as the standard type

Stainless Steel Rod Length

Model	Min. length	Max. length	Note
32	250 mm	1800 mm	Can be manufactured in increments of 1 mm up to the maximum length.
40	250 mm	2500 mm	
50	300 mm		
63	300 mm		
80	300 mm		
100	300 mm		

Model Selection

Working Principle

CP96N

Double Acting, Single Rod

Double Acting, Double Rod

C96N

Double Acting, Single Rod

Double Acting, Double Rod

Lock Unit MWB-UT

Accessories

Auto Switch

Made to Order

Specific Product Precautions



CP96N/C96N Series Specific Product Precautions 1

Be sure to read this before handling the products. Refer to the back cover for safety instructions. For actuator and auto switch precautions, refer to the "Handling Precautions for SMC Products" and the "Operation Manual" on the SMC website: <https://www.smc.eu>

Design of Equipment and Machinery

Warning

- Construct so that the human body will not come into direct contact with driven objects or the moving parts of the cylinders with lock.**
Devise a safe structure by attaching protective covers that prevent direct contact with the human body, or in cases where there is a danger of contact, provide sensors or other devices to perform an emergency stop, etc., before contact occurs.
- Use a balance circuit, taking cylinder lurching into consideration.**
In cases such as an intermediate stop, where a lock is operated at a desired position within the stroke and air pressure is applied from only one side of the cylinder, the piston will lurch at high speed when the lock is released. In such situations, there is a danger of causing human injury by having hands or feet, etc. caught, and also a danger for causing damage to the equipment. In order to prevent this lurching, a balance circuit such as the recommended pneumatic circuits (page 51) should be used.

Selection

Warning

- When in the locked state, do not apply a load accompanied by an impact shock, strong vibration or turning force, etc.**
Use caution, because an external action such as an impacting load, strong vibration or turning force, may damage the locking mechanism or reduce its life.
 - Consider stopping accuracy and the amount of overrun when an intermediate stop is performed.**
Due to the nature of a mechanical lock, there is a momentary lag with respect to the stop signal, and a time delay occurs before stopping. The cylinder stroke resulting from this delay is the overrun amount. The difference between the maximum and minimum overrun amounts is the stopping accuracy.
 - Place a limit switch before the desired stopping position, at a distance equal to the overrun amount.
 - The limit switch must have a detection length (dog length) of the overrun amount + α .
 - SMC's auto switches have operating ranges from 8 to 14 mm (depending on the auto switch model).**When the overrun amount exceeds this range, self-holding of the contact should be performed at the auto switch load side.**
- * For the stopping accuracy, refer to pages 10 and 26.

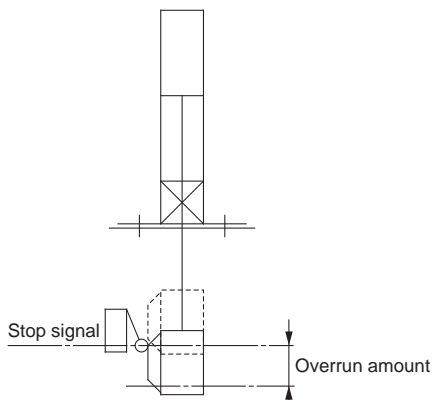

Selection

Warning

- In order to further improve stopping accuracy, the time from the stop signal to the operation of the lock should be shortened as much as possible.**
To accomplish this, use a device such as a highly responsive electric control circuit or solenoid valve, and place the solenoid valve as close as possible to the cylinder.
- Note that the stopping accuracy will be influenced by changes in piston speed.**
When piston speed changes during the course of the cylinder stroke due to variations in the load or disturbances, etc., the dispersion of stopping positions will increase. Therefore, consideration should be given to establishing a standard speed for the piston just before it reaches the stopping position.
Moreover, the dispersion of stopping positions will increase during the cushioned portion of the stroke and during the accelerating portion of the stroke after the start of operation, due to the large changes in piston speed.
- The holding force (max. static load) indicates the maximum capability to hold a static load without loads, vibration and impact. This does not indicate a load that can be held in ordinary conditions.**
Select the most suitable bore sizes for the operating conditions in accordance with the selection procedures. The Model Selection (pages 6 and 7) is based on use at the intermediate stop (including emergency stops during operation). However, when the cylinder is in a locked state, kinetic energy does not act upon it. Under these conditions, use the load mass at the maximum speed (V) of 100 mm/s shown in graphs [5] to [7] on page 7 depending on the operating pressure and select models.

Mounting

Warning

- The manual lock is released as default. The lock will not operate in this condition. Before starting operation, engage the lock.**
- Be certain to connect the rod end to the load with the lock released.**
If connected in the locked state, a load greater than the turning force or holding force, etc. may operate on the piston rod and cause damage to the lock mechanism. As the C(P)96N series is equipped with a manual lock release mechanism, it is possible to hold the lock released state without an air supply.
- Do not apply offset loads to the piston rod.**
Particular care should be taken to match the load's centre of gravity with the centre of the cylinder shaft. When there is a large discrepancy, the piston rod may be subjected to uneven wear or damage due to the inertial moment during locking stops.

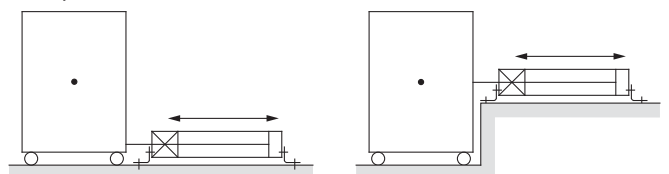

X Load center of gravity and cylinder shaft center are not matched.

O Load center of gravity and cylinder shaft center are matched.

* Can be used if all of the generated moment is absorbed by an effective guide.



CP96N/C96N Series Specific Product Precautions 2

Be sure to read this before handling the products. Refer to the back cover for safety instructions. For actuator and auto switch precautions, refer to the “Handling Precautions for SMC Products” and the “Operation Manual” on the SMC website: <https://www.smc.eu>

Mounting

⚠ Caution

1. Use the hexagon wrenches shown below when replacing brackets.

Bore size [mm]	Width across flats	Tightening torque [N·m]
32, 40	4	4.8
50, 63	5	10.4
80, 100	6	18.2

2. When replacing the head side bracket, the tie-rod nut on the cylinder body also loosens.

After retightening the tie-rod nut at the proper tightening torque (refer to the Mounting 1. above.), install the bracket.

3. Do not turn the piston rod with the rod boot kept locked.

When turning the piston rod, loosen the band once and do not twist the rod boot.

Set the breathing hole in the rod boot downward or in the direction that prevents entry of dust or water content.

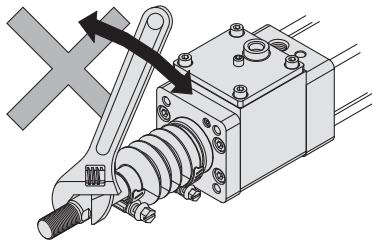

4. Do not disassemble the trunnion type cylinder because the mounting precision is required.

It is difficult to align the axial centre of the trunnion with the axial centre of the cylinder. Thus, if this type of cylinder is disassembled and reassembled, the required dimensional accuracy cannot be attained, which may lead to malfunctions.

Adjustment

⚠ Warning

1. Do not open the cushion valve more than the allowable number of rotations (table on the right).

Although the cushion valve is caulked as a retaining mechanism, do not open the cushion valve more than the allowable number of rotations. If air is supplied and operation started without confirming the above condition, the cushion valve may be ejected from the cover.

The allowable number of rotations refers to the number of rotations until the restrictor of the cushion valve is completely opened from the completely closed state.

Adjustment

⚠ Warning

2. Keep the screwing torque and the unscrewing torque of the cushion valve to the allowable torque or below (following table).

If a screwing torque or unscrewing torque beyond the allowable torque is applied, the valve will be damaged when the valve is closed completely or exceeds the retaining mechanism when the valve is opened completely, which will dislocate the engagement of the screw and eject the valve.

Bore size [mm]	Cushion valve width across flats	Hexagon wrench	Allowable number of rotations	Allowable torque [N·m]
32, 40	2	JIS 4648 Hexagon wrench key 2	4	0.02
50, 63	2	JIS 4648 Hexagon wrench key 2	4.5	0.02
80, 100	3	JIS 4648 Hexagon wrench key 3	5.5	0.06

3. Be certain to activate the air cushion at the stroke end.

When the air cushion is inactivated, if the allowable kinetic energy exceeds the value on pages 11 and 27, the piston rod assembly or the tie-rod may be damaged. Set the air cushion to valid when operating the cylinder.

⚠ Caution

1. Adjust the cylinder's air balance.

Balance the load by adjusting the air pressure in the rod and head sides of the cylinder with the load connected to the cylinder and the lock released. Lurching of the cylinder when unlocked can be prevented by carefully adjusting this air balance.

2. Adjust the mounting positions of the detectors on auto switches, etc.

When intermediate stops are to be performed, adjust the mounting positions of detectors on auto switches, etc., taking into consideration the overrun amount with respect to the desired stopping positions.

Model Selection

Working Principle

CP96N

Double Acting, Single Rod

Double Acting, Double Rod

C96N

Double Acting, Single Rod

Double Acting, Double Rod

Lock Unit
MWB-UT

Accessories

Auto Switch

Made to Order

Specific Product Precautions



CP96N/C96N Series Specific Product Precautions 3

Be sure to read this before handling the products. Refer to the back cover for safety instructions. For actuator and auto switch precautions, refer to the “Handling Precautions for SMC Products” and the “Operation Manual” on the SMC website: <https://www.smc.eu>

Pneumatic Circuit

Warning

1. Be certain to use a pneumatic circuit which will apply balancing pressure to both sides of the piston when in a locked stop.

In order to prevent cylinder lurching after a lock stop, when restarting or when manually unlocking, a circuit should be used to which will apply balancing pressure to both sides of the piston, thereby canceling the force generated by the load in the direction of piston movement.

2. The effective area of the unlocking solenoid valve should be at least 50 % of the effective area of the cylinder driving solenoid valve, and it should be installed as close to the cylinder as possible so that it is closer than the cylinder driving solenoid valve.

If the effective area of the unlocking solenoid valve is small or if it is installed at a distance from the cylinder, the time required for exhausting air for unlocking will be longer, which may cause a delay in the locking operation.

The delay in the locking operation may result in problems such as increase of overruning when performing intermediate stop or emergency stop during operation, or if maintaining position from the operation stop state such as drop prevention, workpieces may be dropped depending on the timing of the load action to the operation delay of the lock.

3. Avoid backflow of the exhaust pressure when there is a possibility of interference of exhaust air, for example for a common exhaust type valve manifold.

The lock may not operate properly when the exhaust air pressure backflows due to interference of the exhaust air when exhausting air for lock release. It is recommended to use an individual exhaust type manifold or individual valves.

4. Allow at least 0.5 seconds from a locked stop (intermediate stop of the cylinder) until release of the lock.

When the locked stop time is too short, the piston rod (and load) may lurch at a speed greater than the control speed of the speed controller.

5. When restarting, control the switching signal for the unlocking solenoid valve so that it acts before or at the same time as the cylinder drive solenoid valve.

If the signal is delayed, the piston rod (and load) may lurch at a speed greater than the control speed of the speed controller.

6. Carefully check for dew condensation due to repeated air supply and exhaust of the locking solenoid valve.

The operating stroke of the lock part is very small. So, if the piping is long and the air supply and exhaust are repeated, the dew condensation caused by the adiabatic expansion accumulates in the lock part. This may corrode internal parts, causing air leak or lock release fault.

Warning

7. Basic circuit

1. [Horizontal]

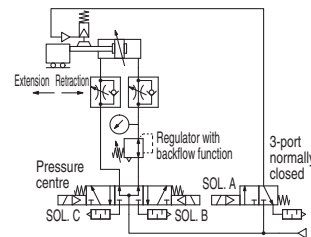

SOL A	SOL B	SOL C	Action
ON	ON	OFF	Extension
OFF	OFF	OFF	Locked stop
ON	OFF	OFF	Unlocked
ON	ON	OFF	Extension
ON	OFF	ON	Retraction
OFF	OFF	OFF	Locked stop
ON	OFF	OFF	Unlocked
ON	OFF	ON	Retraction

← 0.5 s or more
 ← 0 to 0.5 s
 ← 0.5 s or more
 ← 0 to 0.5 s

2. [Vertical]

[Load in the direction of rod extension]

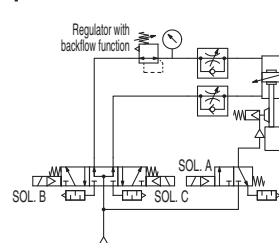

[Load in the direction of rod retraction]

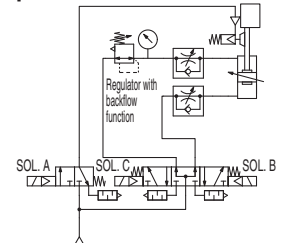

* The symbol for the cylinder with lock in the basic circuit uses SMC original symbol.

Caution

1. 3-position pressure centre solenoid valve and regulator with backflow function can be replaced with two 3-port normally open valves and a regulator with relief function.

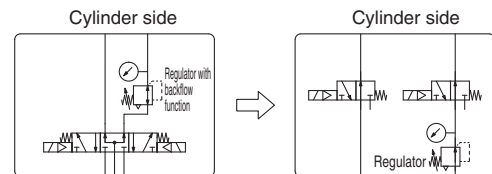

[Example]

1. [Horizontal]

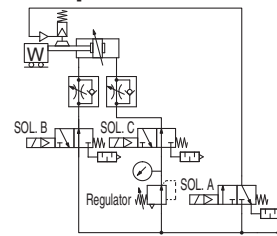

2. [Vertical]

[Load in the direction of rod extension]

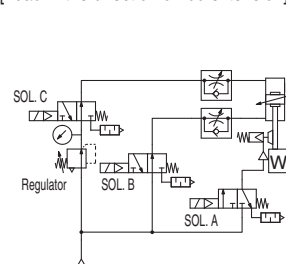

[Load in the direction of rod retraction]

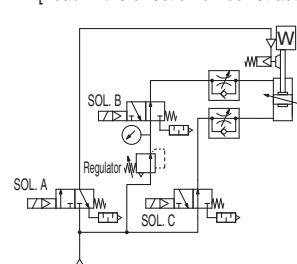

* The symbol for the cylinder with lock in the pneumatic circuit uses SMC original symbol.



CP96N/C96N Series Specific Product Precautions 4

Be sure to read this before handling the products. Refer to the back cover for safety instructions. For actuator and auto switch precautions, refer to the “Handling Precautions for SMC Products” and the “Operation Manual” on the SMC website: <https://www.smc.eu>

Manual Lock Release

Warning

- Never operate the lock release bolt until safety has been confirmed.
 - When unlocking is performed with air pressure applied to only one side of the cylinder, the moving parts of the cylinder will lurch at high speed causing a serious hazard.
 - When unlocking is performed, be sure to confirm that personnel are not within the load movement range and that no other problems will occur if the load moves.
- Before operating the lock release bolt, exhaust any residual pressure which is in the system.
- Take measures to prevent the load from dropping.
 - Perform work with the load in its lowest position.
 - Take measures for drop prevention by strut, etc.

Caution

- When releasing the locked state with the lock release bolt for the purpose of mounting or adjustment, be sure to return the lock release bolt to the locked state.

If the lock release bolt is not returned to the locked state, the lock might not function correctly or lock release might not be completed due to air leakage from the lock release bolt.

[How to return to locked state]

- Rotate the lock release bolt counterclockwise by hand with a hexagon wrench until it stops. Once that position is reached, rotate it an additional 1/6th of a turn to securely tighten the lock release bolt.

* Do not use an electric screwdriver or pneumatic screwdriver.

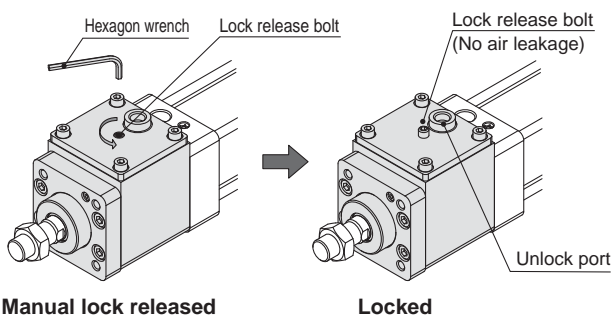

Bore size [mm]	Hexagon wrench size of the lock release bolt
32, 40	3
50, 63	4
80, 100	5

- Pressurise the unlock port with 0.3 MPa or more and check that there is no air leakage from the lock release bolt and lock correctly functions.

Maintenance

Caution

- Lock units are replaceable.

When ordering the lock unit for maintenance, select the suitable lock based on the cylinder bore size.

Bore size [mm]	Port type	Replacement lock unit part no.
32	G	MWB32TF-UA
40	G	MWB40TF-UA
50	G	MWB50TF-UA
63	G	MWB63TF-UA
80	G	MWB80TF-UA
100	G	MWB100TF-UA

* For lock unit with a rod boot, add -J to the part number suffix.
Example) MWB50TF-UA-J

- How to replace lock units

The following method is described using CP96N, however, it can equally be applied to the C96N.

- To release the locked state, screw-in the lock release bolt to the body cap end or pressurize the unlock port with 0.3 MPa or more.

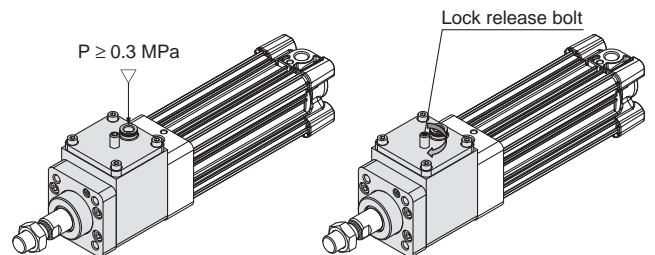

a) Lock released by air pressure

b) Manual lock release

- Remove the lock unit holding bolt (hexagon socket head cap screw) with a hexagon wrench. For the applicable hexagon wrench, refer to the table below.
If using the rod end nut, remove it.

Bore size [mm]	Hexagon wrench size of the lock unit holding bolt
32	3
40, 50	5
63	6
80	8
100	10

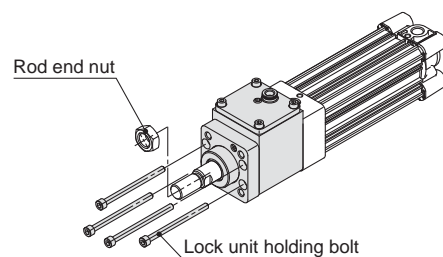

Model Selection

Working Principle

CP96N

Double Acting, Single Rod

Double Acting, Double Rod

C96N

Double Acting, Single Rod

Double Acting, Double Rod

Lock Unit MWB-UT

Accessories

Auto Switch

Made to Order

Specific Product Precautions



CP96N/C96N Series Specific Product Precautions 5

Be sure to read this before handling the products. Refer to the back cover for safety instructions. For actuator and auto switch precautions, refer to the “Handling Precautions for SMC Products” and the “Operation Manual” on the SMC website: <https://www.smc.eu>

Maintenance

Caution

3) Pull out the old lock unit from the cylinder.

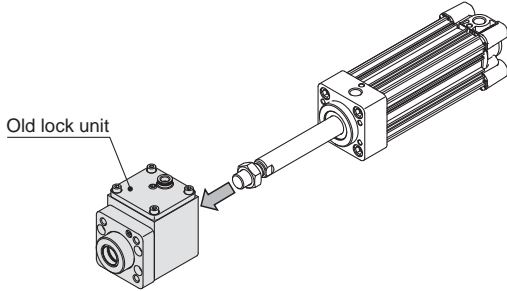

4) Insert a new lock unit into the cylinder.
The lock unit for maintenance is supplied with lock released state at the shipment from the factory.

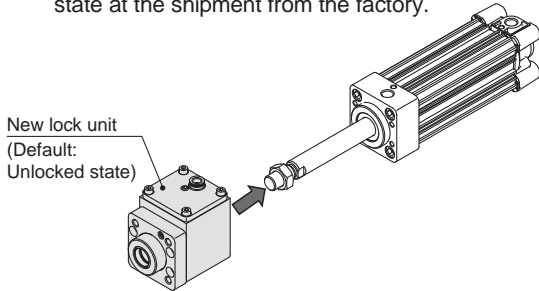

5) Insert the lock unit holding bolt and tighten it temporarily.
Check that the piston rod operates smoothly by hand while maintaining the lock released state.

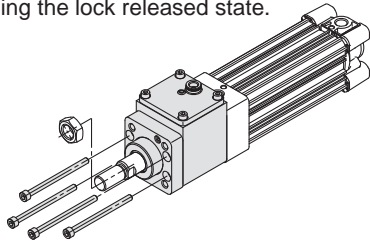

6) Confirm that the operation of 5) is performed correctly, and then tighten the lock unit holding bolt with an appropriate tightening torque as shown in the table below.

Bore size [mm]	Appropriate tightening torque of the lock unit holding bolt [N·m]
32	1.35 to 1.65
40, 50	4.7 to 5.7
63	11.3 to 13.7
80	22.1 to 26.9
100	37.8 to 46.2

7) After assembly is completed, rotate the lock release bolt counterclockwise by hand with a hexagon wrench until it stops. Once that position is reached, rotate it for an additional 1/6th of a turn to securely tighten the lock release bolt.

* Do not use an electric screwdriver or pneumatic screwdriver.

Bore size [mm]	Hexagon wrench size of the lock release bolt
32, 40	3
50, 63	4
80, 100	5

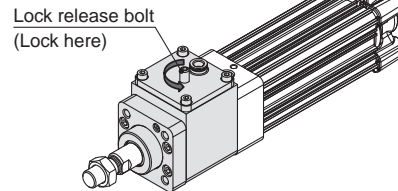

Check that the cylinder is locked and confirm that the lock is released when air pressure of 0.3 MPa or more is applied to the unlock port on the lock unit. In addition to this, the piston rod should operate smoothly with the minimum operating pressure. Check that there is no air leakage from the lock release bolt.



MWB□-UT Series Specific Product Precautions

Be sure to read this before handling the products. Refer to the back cover for safety instructions. For actuator and auto switch precautions, refer to the “Handling Precautions for SMC Products” and the “Operation Manual” on the SMC website: <https://www.smc.eu>

<Precautions for the lock unit MWB□-UT>

Design / Selection

- When selecting a lock unit, refer to Model Selection on pages 6 and 7.
- Use a rod of the size recommended in the following table.

Unit model	MWB32-UT	MWB40-UT	MWB50-UT	MWB63-UT	MWB80-UT	MWB100-UT
Applicable rod size	Ø 12 f8	Ø 16 f8	Ø 20 f8	Ø 20 f8	Ø 25 f8	Ø 30 f8
Material	Carbon steel/Stainless steel					
Surface treatment	Hard chrome plating: 10 µm					
Surface roughness	Maximum height: Rz 1.6 or less					

Using any rod other than the rods recommended above may cause damage to internal parts of the lock unit, faulty mounting of the lock unit, operation failure, decrease in holding force, etc.

- The lock unit may be damaged if an excessive lateral load or external force is applied to it. Fully consider this point.
- Do not use the lock unit for any application where the rod rotates.
- When in the locked state, do not apply a load accompanied by an impact shock, strong vibration, turning force, etc.
Note that an external action, such as an impacting load, strong vibration, or turning force, may damage the lock unit or reduce its life.
- Excessively long piping between the unlock port of the lock unit and the solenoid valve for the lock, or a pipe that is too small may affect the stopping accuracy of the lock unit.
- When unlocking is performed from the locked state with some thrust or load still applied to the lock unit, cylinder lurching may occur. In addition, frequent occurrence of excessive cylinder lurching or a similar problem due to the load being applied will damage the lock unit or reduce its life. Take appropriate measures for the circuit and/or the system. When using the lock unit in combination with a pneumatic cylinder, cylinder lurching can be prevented by using a balance circuit, such as the recommended pneumatic circuits on page 51.
- When using the lock unit by placing it in parallel with the cylinder for driving as shown in the figure below, align the cylinder with the rod.

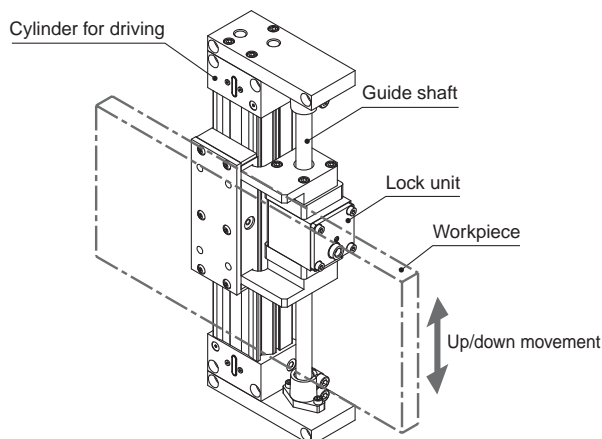

Mounting / Adjustment

- Ensure that the sliding surface of the rod to be inserted into the lock unit is not scratched or dented during the mounting or adjustment of this product.

Scratches or dents on the surface of the rod may cause unusual wear on the inner surface of the brake pad or decrease its holding force.

- Chamfer the rod end to be inserted into the lock unit as shown in the figures below to prevent the seal and inner periphery of the lock unit from being scratched.

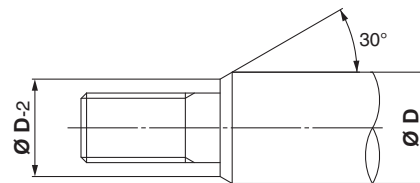

For male thread

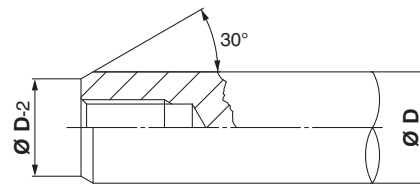

For female thread

- Refer to page 52 for the manual lock release.

Maintenance / Inspection

- Do not disassemble the lock unit and perform maintenance.
Please contact our nearest sales office when you require repair or maintenance.
- Do not apply any grease or lubricant to the inner periphery of the lock unit or the surface of the rod to be inserted into the lock unit.
Doing so may result in a decrease in holding force.
- Take additional safety measures when conducting equipment maintenance.

Model Selection

Working Principle

CP96N

Double Acting, Single Rod

Double Acting, Double Rod

C96N

Double Acting, Single Rod

Double Acting, Double Rod

Lock Unit MWB-UT

Accessories



Auto Switch

Made to Order

Specific Product Precautions

Safety Instructions

These safety instructions are intended to prevent hazardous situations and/or equipment damage. These instructions indicate the level of potential hazard with the labels of “Caution,” “Warning” or “Danger.” They are all important notes for safety and must be followed in addition to International Standards (ISO/IEC)*1), and other safety regulations.

-  **Caution:** Caution indicates a hazard with a low level of risk which, if not avoided, could result in minor or moderate injury.
-  **Warning:** Warning indicates a hazard with a medium level of risk which, if not avoided, could result in death or serious injury.
-  **Danger:** Danger indicates a hazard with a high level of risk which, if not avoided, will result in death or serious injury.

- *1) ISO 4414: Pneumatic fluid power – General rules relating to systems.
 ISO 4413: Hydraulic fluid power – General rules relating to systems.
 IEC 60204-1: Safety of machinery – Electrical equipment of machines.
 (Part 1: General requirements)
 ISO 10218-1: Manipulating industrial robots - Safety.
 etc.

Warning

1. The compatibility of the product is the responsibility of the person who designs the equipment or decides its specifications.

Since the product specified here is used under various operating conditions, its compatibility with specific equipment must be decided by the person who designs the equipment or decides its specifications based on necessary analysis and test results. The expected performance and safety assurance of the equipment will be the responsibility of the person who has determined its compatibility with the product. This person should also continuously review all specifications of the product referring to its latest catalogue information, with a view to giving due consideration to any possibility of equipment failure when configuring the equipment.

2. Only personnel with appropriate training should operate machinery and equipment.

The product specified here may become unsafe if handled incorrectly. The assembly, operation and maintenance of machines or equipment including our products must be performed by an operator who is appropriately trained and experienced.

3. Do not service or attempt to remove product and machinery/equipment until safety is confirmed.

- The inspection and maintenance of machinery/equipment should only be performed after measures to prevent falling or runaway of the driven objects have been confirmed.
- When the product is to be removed, confirm that the safety measures as mentioned above are implemented and the power from any appropriate source is cut, and read and understand the specific product precautions of all relevant products carefully.
- Before machinery/equipment is restarted, take measures to prevent unexpected operation and malfunction.

4. Contact SMC beforehand and take special consideration of safety measures if the product is to be used in any of the following conditions.

- Conditions and environments outside of the given specifications, or use outdoors or in a place exposed to direct sunlight.
- Installation on equipment in conjunction with atomic energy, railways, air navigation, space, shipping, vehicles, military, medical treatment, combustion and recreation, or equipment in contact with food and beverages, emergency stop circuits, clutch and brake circuits in press applications, safety equipment or other applications unsuitable for the standard specifications described in the product catalogue.
- An application which could have negative effects on people, property, or animals requiring special safety analysis.
- Use in an interlock circuit, which requires the provision of double interlock for possible failure by using a mechanical protective function, and periodical checks to confirm proper operation.

Limited warranty and Disclaimer/ Compliance Requirements

The product used is subject to the following “Limited warranty and Disclaimer” and “Compliance Requirements”.

Read and accept them before using the product.

Limited warranty and Disclaimer

- The warranty period of the product is 1 year in service or 1.5 years after the product is delivered, whichever is first.*2) Also, the product may have specified durability, running distance or replacement parts. Please consult your nearest sales branch.
- For any failure or damage reported within the warranty period which is clearly our responsibility, a replacement product or necessary parts will be provided. This limited warranty applies only to our product independently, and not to any other damage incurred due to the failure of the product.
- Prior to using SMC products, please read and understand the warranty terms and disclaimers noted in the specified catalogue for the particular products.

*2) Vacuum pads are excluded from this 1 year warranty.

A vacuum pad is a consumable part, so it is warranted for a year after it is delivered. Also, even within the warranty period, the wear of a product due to the use of the vacuum pad or failure due to the deterioration of rubber material are not covered by the limited warranty.

Compliance Requirements

- The use of SMC products with production equipment for the manufacture of weapons of mass destruction (WMD) or any other weapon is strictly prohibited.
- The exports of SMC products or technology from one country to another are governed by the relevant security laws and regulations of the countries involved in the transaction. Prior to the shipment of a SMC product to another country, assure that all local rules governing that export are known and followed.

Caution

1. The product is provided for use in manufacturing industries.

The product herein described is basically provided for peaceful use in manufacturing industries.

If considering using the product in other industries, consult SMC beforehand and exchange specifications or a contract if necessary.

If anything is unclear, contact your nearest sales branch.

Caution

SMC products are not intended for use as instruments for legal metrology.

Measurement instruments that SMC manufactures or sells have not been qualified by type approval tests relevant to the metrology (measurement) laws of each country.

Therefore, SMC products cannot be used for business or certification ordained by the metrology (measurement) laws of each country.

Safety Instructions

Be sure to read “Handling Precautions for SMC Products” (M-E03-3) before using.

SMC Corporation (Europe)

Austria	☎+43 (0)2262622800	www.smc.at	office@smc.at
Belgium	☎+32 (0)33551464	www.smc.be	info@smc.be
Bulgaria	☎+359 (0)2807670	www.smc.bg	office@smc.bg
Croatia	☎+385 (0)13707288	www.smc.hr	office@smc.hr
Czech Republic	☎+420 541424611	www.smc.cz	office@smc.cz
Denmark	☎+45 70252900	www.smc.dk.com	smc@smcdk.com
Estonia	☎+372 6510370	www.smc.pneumatics.ee	smc@smcpneumatics.ee
Finland	☎+358 207513513	www.smc.fi	smc@smc.fi
France	☎+33 (0)164761000	www.smc-france.fr	info@smc-france.fr
Germany	☎+49 (0)61034020	www.smc.de	info@smc.de
Greece	☎+30 210 2717265	www.smc.hellas.gr	sales@smchellas.gr
Hungary	☎+36 23513000	www.smc.hu	office@smc.hu
Ireland	☎+353 (0)14039000	www.smc.pneumatics.ie	sales@smcpneumatics.ie
Italy	☎+39 0292711	www.smc.italia.it	mailbox@smc.italia.it
Latvia	☎+371 67817700	www.smc.lv	info@smc.lv

Lithuania	☎+370 5 2308118	www.smc.lt	info@smc.lt
Netherlands	☎+31 (0)205318888	www.smc.nl	info@smc.nl
Norway	☎+47 67129020	www.smc-norge.no	post@smc-norge.no
Poland	☎+48 222119600	www.smc.pl	office@smc.pl
Portugal	☎+351 214724500	www.smc.eu	apoioclientept@smc.smces.es
Romania	☎+40 213205111	www.smcromania.ro	smcromania@smcromania.ro
Russia	☎+7 8127185445	www.smc-pneumatik.ru	info@smc-pneumatik.ru
Slovakia	☎+421 (0)413213212	www.smc.sk	office@smc.sk
Slovenia	☎+386 (0)73885412	www.smc.si	office@smc.si
Spain	☎+34 945184100	www.smc.es	post@smc.smces.es
Sweden	☎+46 (0)86031200	www.smc.nu	post@smc.nu
Switzerland	☎+41 (0)523963131	www.smc.ch	helpcenter@smc.ch
Turkey	☎+90 212 489 0 440	www.smc.pneumatik.com.tr	info@smcpneumatik.com.tr
UK	☎+44 (0)845 121 5122	www.smc.uk	sales@smc.uk