

Air Saving Speed Controller RoHS

Reduce air consumption just by mounting to your air cylinder!

Air consumption reduced by **25 %!!**

Acquire two-pressure control just by mounting the product. Reduces the air supply pressure of the stroke on the non-working side to 0.2 MPa

Mounting and operation are the same as a regular speed controller!!



With pressure reduction function
AS-R Series

With rapid supply and exhaust function
AS-Q Series

Equal response time!

No response time delay with two-pressure control

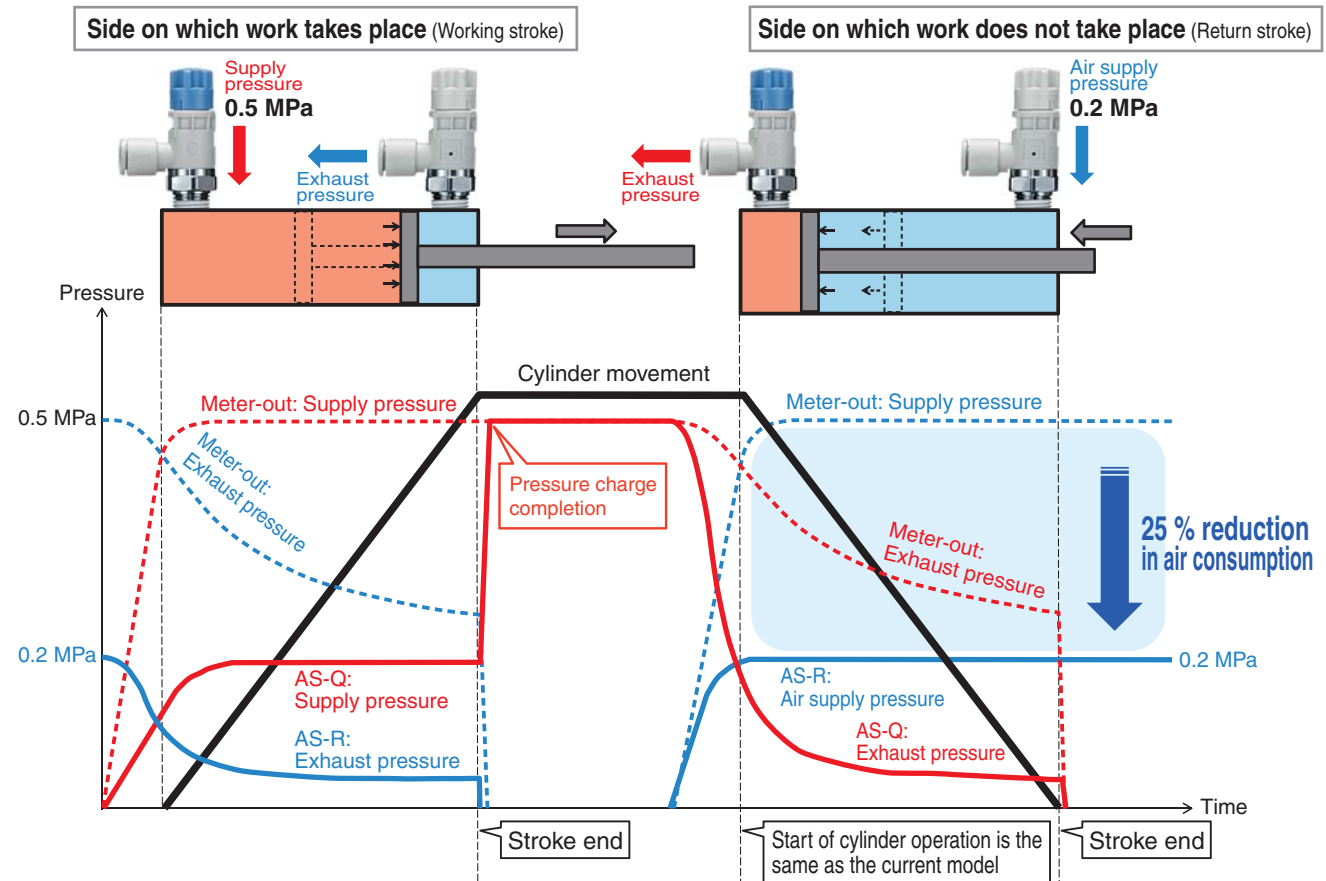

AS-R/AS-Q Series



CAT.EUS20-245C-UK

Air Saving

25^{*1} % reduction in air consumption

By reducing the pressure on the return stroke to 0.2 MPa, air consumption can be reduced.

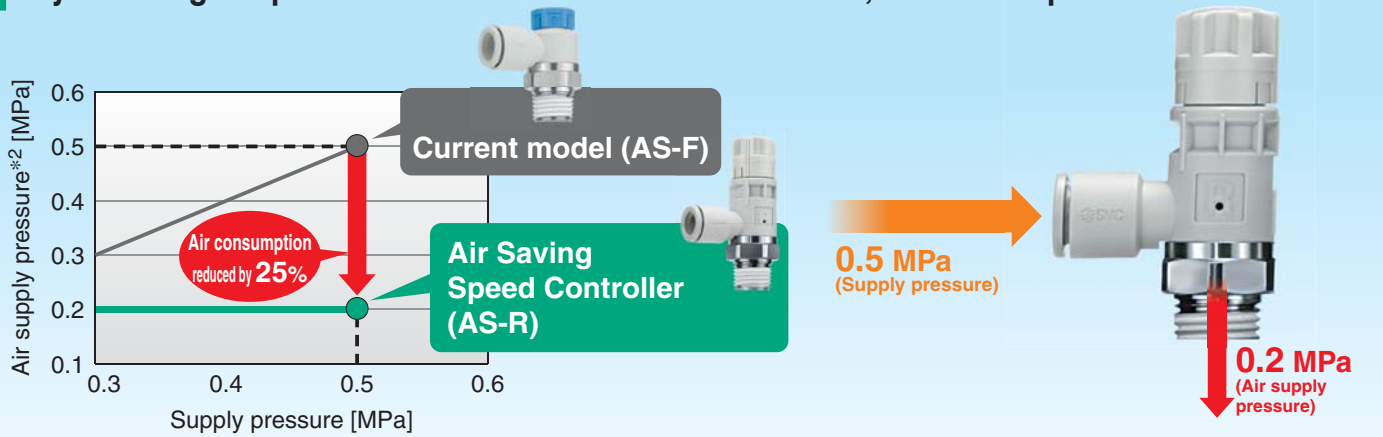

*1 The air consumption reduction rate indicates the rate for one cycle of the cylinder.
 *2 Cylinder pressure on the return stroke side

Compact

85^{*1} % reduction in size

(Occupied volume: 230 cm³ → 34 cm³)

Combines the functions of a regulator and speed controller

*1 Comparison of AR20K-02-B + AS22□1F-02-08 and AS22R-02-08



Easy Adjustment

- Push-lock type
- Only the speed is adjustable.

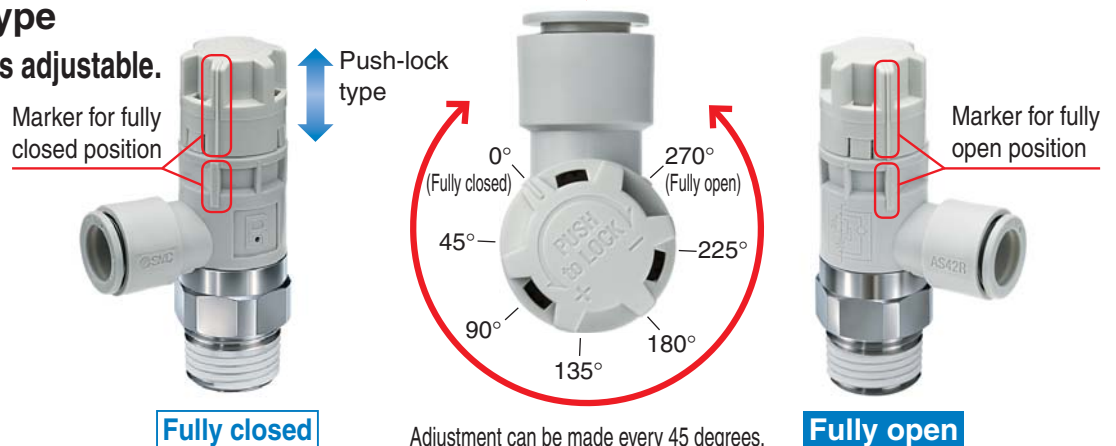

Adjustment can be made every 45 degrees.

Equal Response Time

- Improved output response at the stroke end due to rapid air filling
- Improved response time of return stroke due to rapid air exhaust

Lurch Prevention

As this product is operated by the return stroke at a reduced pressure by the meter-in circuit, the sudden extension of the working stroke can be prevented.

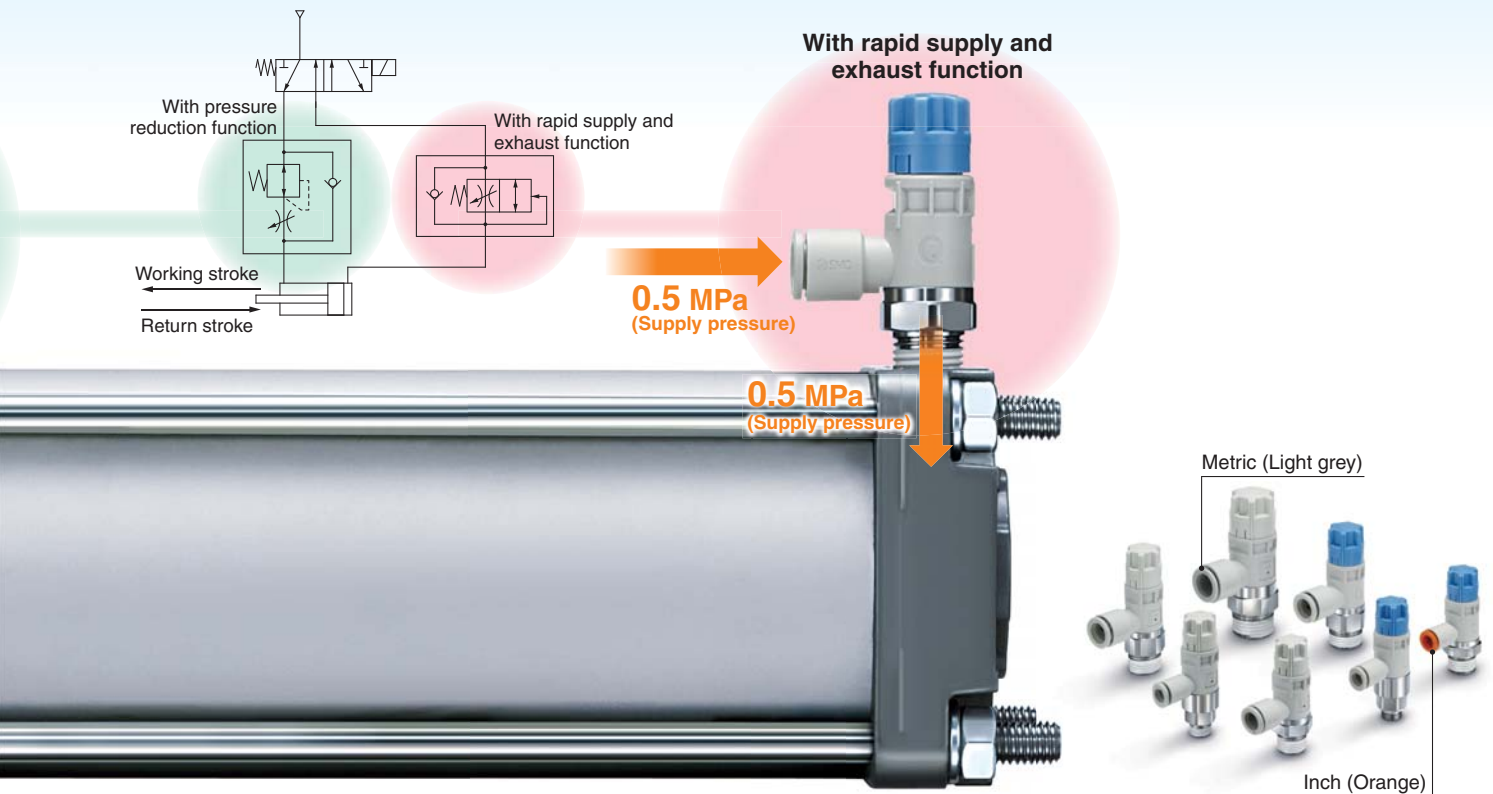

Variations

With pressure reduction function AS-R Series	With rapid supply and exhaust function AS-Q Series	Model (Body size)	Port size	Applicable tubing O.D.								Applicable tubing material
				Metric size (Applicable thread: R, G)				Inch size (Applicable thread: NPT)				
				6	8	10	12	1/4"	5/16"	3/8"	1/2"	
AS22R-□01-□	—	2	1/8	•	•	•		•	•			Nylon (T, TIA series) Soft nylon (TS, TISA series) Polyurethane (TU, TIUB series) Fluororesin (TLM, TILM series) (TH, TIH series)
AS22R-□02-□	AS22Q-□02-□		1/4	•	•	•		•	•			
AS32R-□02-□	AS32Q-□02-□	3	1/4	•	•	•		•	•			
AS32R-□03-□	AS32Q-□03-□		3/8	•	•	•		•	•			
AS42R-□03-□	AS42Q-□03-□	4	3/8			•	•		•	•		
AS42R-□04-□	AS42Q-□04-□		1/2			•	•		•	•		

Applications and Load

Press fitting, Pressing, Clamping

Applications which generate force: F (N) at the stroke end of the working stroke

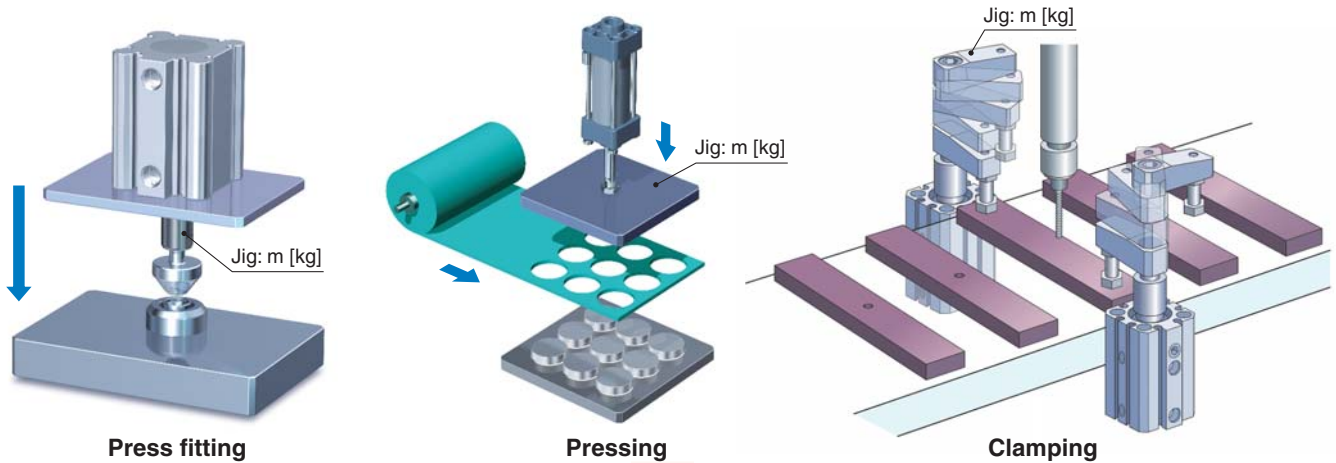

Applicable speed controllers

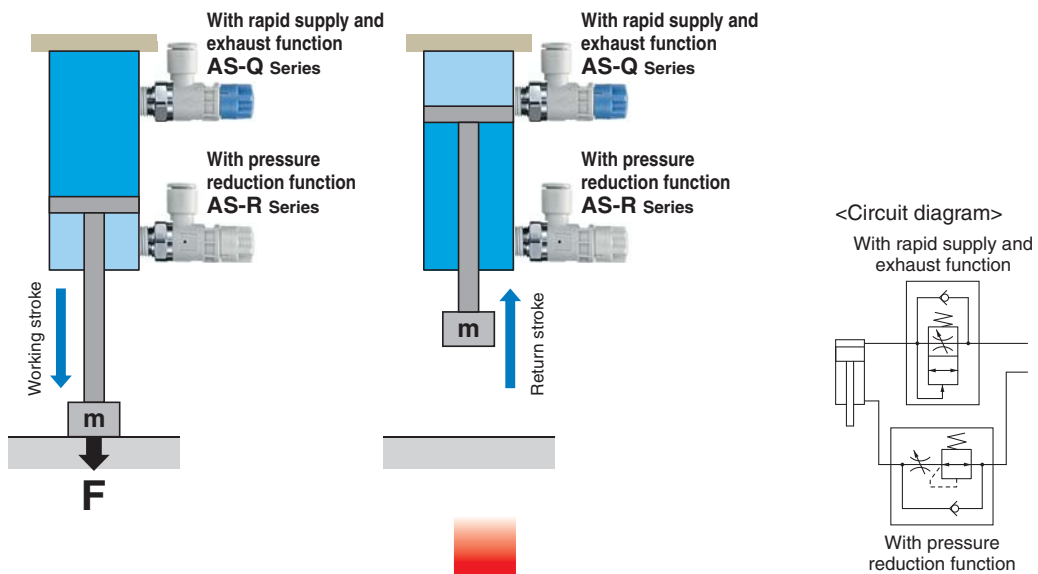

Selection of model and load [When AS-Q (with rapid supply and exhaust function) is used]

- 1 **Applicable cylinder bore size**
- 2 **Air filling time at the stroke end**
- 3 **Jig weight: m**
 → Refer to the Model Selection section of Air Saving Speed Controllers (pages 7 and 8).
- 4 **Force: F**
 → Refer to the Air Cylinders Model Selection section.

Caution

Use the AS-Q for applications which perform operations at the stroke end. As the AS-Q has a rapid air supply function, items 1 and 2 must be specified.

Lifter

Applications which lift workpieces, W (kg), during the working stroke and which have no workpiece load during the return stroke

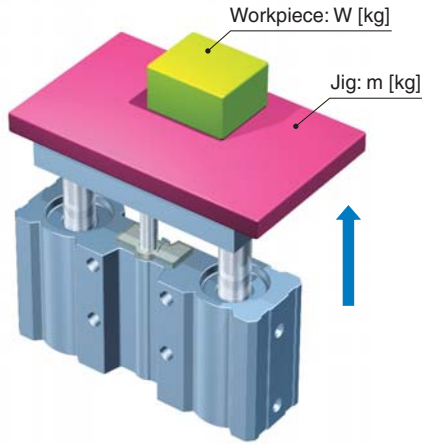

Pusher

Applications which transfer workpieces, W (kg), during the working stroke and which have no workpiece load during the return stroke

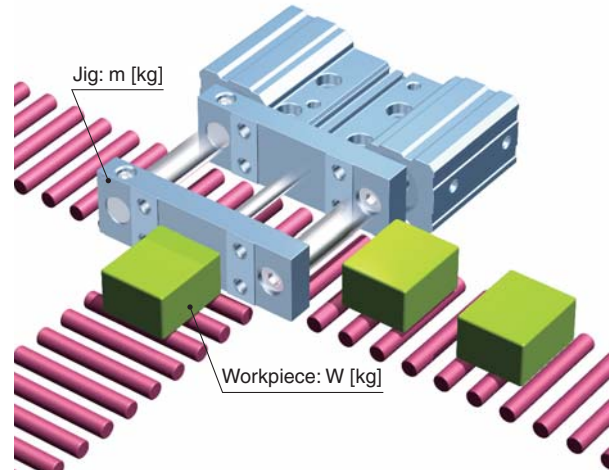

Applicable speed controllers

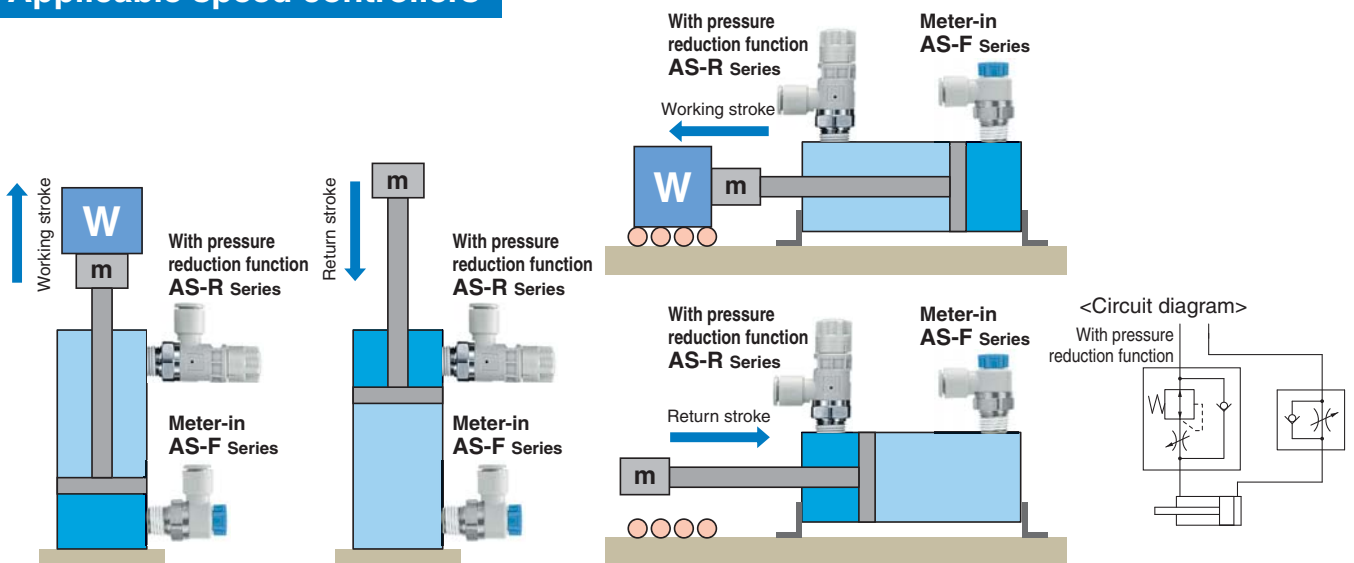

Selection of model and load [When a meter-in type speed controller (AS-F) is used]

1 Jig weight: m

→ Refer to the Model Selection section of Air Saving Speed Controllers (pages 7 and 8).

2 Workpiece: W

→ Refer to the Air Cylinders Model Selection section.

Caution

Use a meter-in type speed controller for applications which perform operations during the working stroke. When a meter-in type speed controller is used, pressure corresponding to the load, W , is supplied to the cylinder to transfer the workpiece. Refer to the technical instructions on page 19 for the characteristics of the meter-in and meter-out speed controllers.

Application Proposal for Air Saving Speed Controllers

Air consumption reduction ratio: **50%**

* Comparison of air consumption when the supply pressure is 0.5 MPa
 * In this case, the load to move the workpiece is piston area multiplied by 0.2 MPa.

Pusher

- Applications which transfer workpieces, W (kg), during the working stroke and which have no workpiece (or load) during the return stroke
- The cylinder is returned right after reaching the end of the working stroke so that **air consumption can be reduced without unnecessary filling.**

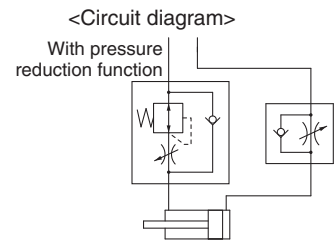
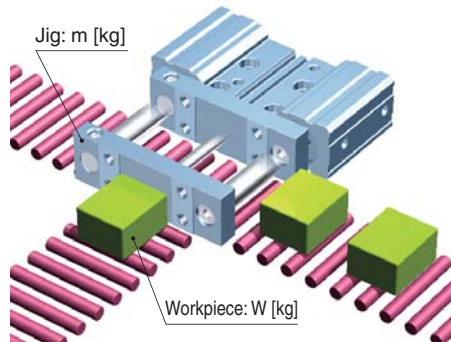

<Load and applicable speed controller>

- 1 Start the stroke operation by turning the solenoid valve ON.
- 2 The solenoid valve is turned off at the end of the working stroke.
 - Air consumption can be reduced by shutting off the air supply before the internal pressure of the cylinder reaches the supply pressure.
- 3 The air consumption of the return stroke can be reduced by supplying the pressure which has been saved by the AS-R.

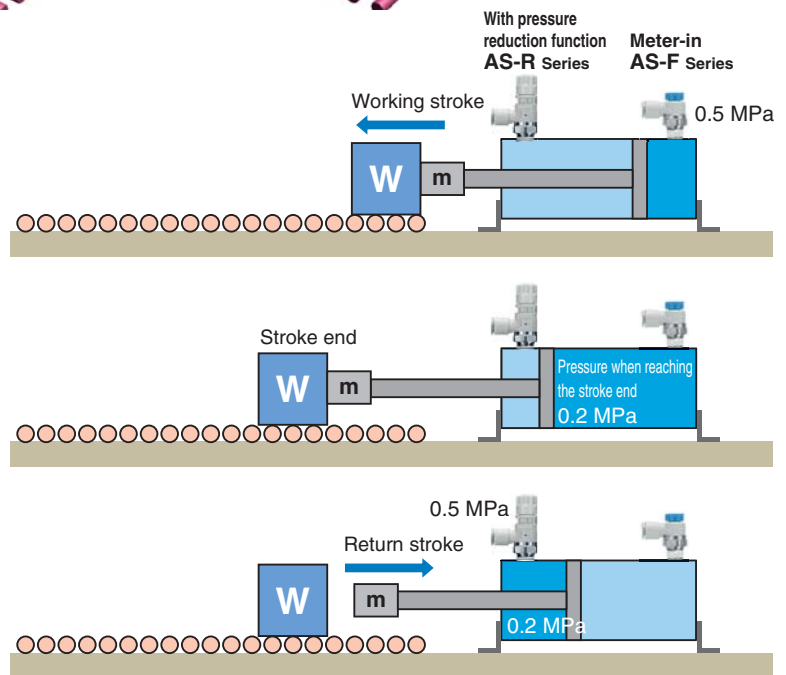

Air consumption reduction ratio: **46%**

Combination with an Optimally-sized Cylinder

For example, instead of using an Ø 80 bore cylinder in place of a Ø 63 bore cylinder that does not have enough force, it is possible to select an optimally-sized Ø 67 bore JMB series cylinder. In addition, an AS-R/AS-Q series combined with this cylinder can reduce air consumption by up to 46%.

Air Consumption (for one cycle)

Speed controller	Air Saving Speed Controller AS-R/AS-Q Series	Elbow type AS Series
Cylinder bore size [mm]	Ø 67 (Intermediary bore size)	Ø 80
Air consumption [L]	3.1	5.8

Conditions:
 Working stroke pressure: 0.5 MPa
 Return stroke pressure: 0.2 MPa
 Stroke: 100 mm
 * Utilizes the SMC sizing program

46% reduction

Air Saving Speed Controller



Air Cylinder JMB Series Intermediary bore size



	Ø 63	Ø 67 (Intermediary bore size)	Ø 80
Bore size	Ø 63	Ø 67	Ø 80
Force	Not acceptable	Acceptable (Optimal)	Acceptable (Excessive)

CONTENTS

Air Saving Speed Controller *AS-R/AS-Q Series*



Model Selection	P.7
Model	P.9
Specifications	P.9
Sonic Conductance and Critical Pressure Ratio	P.9
How to Order	P.10
Flow Rate Characteristics	P.11
Pressure Characteristics (AS-R)	P.11
Cylinder Speed at Maximum Needle Rotation Angle (Guide)	P.12
Construction	P.13
Dimensions: AS-R (Sealant)	P.14
Dimensions: AS-Q (Sealant)	P.15
Dimensions: AS-R (Face seal)	P.16
Dimensions: AS-Q (Face seal)	P.17
Pressure Time Chart	P.18
Construction Principle	P.18
Difference between Meter-in and Meter-out Control	P.19
Specific Product Precautions	P.20



AS-R/AS-Q Series Model Selection

1 Selection of Applicable Cylinder Bore Sizes

The bore sizes applicable to the air saving speed controller are shown in Table 1.

Table 1 Applicable Cylinder Bore Size

Cylinder bore size [mm]	AS22R-□-□ AS22Q-□-□	AS32R-□-□ AS32Q-□-□	AS42R-□-□ AS42Q-□-□
32	●		
40	●		
50	●	●	
63		●	
80		●	●
100			●
125			●

Warning

Regarding cylinders

The AS-Q series cannot be used in combination with the cylinders listed in the chart to the below as there is a chance that such cylinders will lurch. As for the CLQ series and the CQ2 series, use with a rubber bumper.

Cylinders that cannot be used
JCQ Series
RQ Series
RLQ Series

2 Selection of Allowable Jig Weights

When the air saving speed controller is used, the jig weight which is mounted to the cylinder should be below the values in the table below. *1

Selection Method

If a jig exceeding the allowable jig weight is mounted, the driving speed will change greatly in the middle of the cylinder stroke, which may cause a sudden extension.

- *1 If the load varies during the stroke, such to push out a workpiece, do not use the AS-Q for control on the extension side. This can cause a sudden extension. In this case, use a meter-in control type speed controller.
- *2 The coefficient of friction of the guide should be 0.5 or less.
- *3 Compare the weight specified based on the cylinder stroke and the allowable lateral load shown in the table and select a weight smaller than the actual weight of the jig.

Table 2 Relation between Cylinder Bore Size and Allowable Weight of Jig Unit: kg

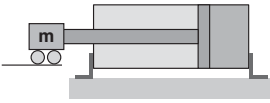
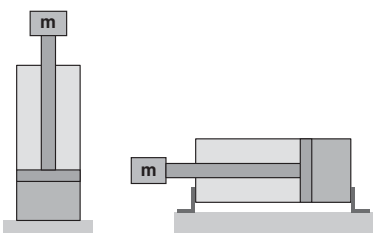
Applicable cylinder bore size [mm]	① Horizontal movement with guide *2	② Vertical and horizontal movement of the load *3
		
32	3.3	1.6
40	5.1	2.6
50	8.0	4.0
63	12.7	6.4
80	20.5	10.3
100	32.1	16.0
125	50.1	25.0

3 Calculation of Fill Time at the Stroke End of the AS-Q with Rapid Supply and Exhaust Function

The fill time at the stroke end can be calculated by multiplying the value read from the graph shown in Figure 1 by the actual fill volume. However, the applicable piston speed is 50 mm/sec or more.

Example: Use AS22Q,
 Needle rotation angle: 90°
 Cylinder tube I.D.: 50 mm
 Stroke: 50 mm

$$\text{Fill time [s]} = \text{Fill time [s/L]} \times \text{Fill volume [L]}$$

$$\text{Fill volume [L]} = \text{Bore size}^2 [\text{mm}^2] \times \pi/4 \times \text{Stroke [mm]} / 10^6$$

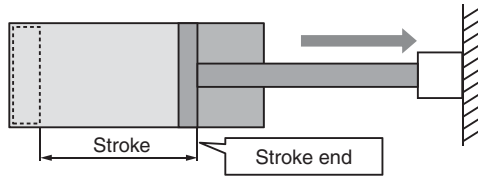

Figure 1. Relation between Needle Rotation Angle and Fill Time

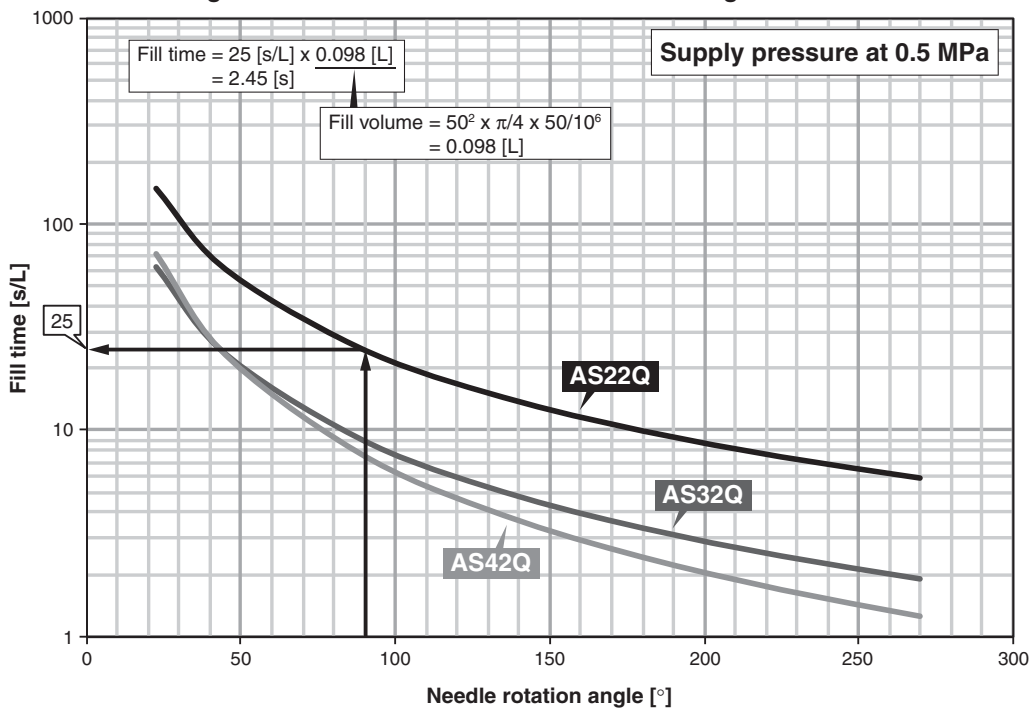
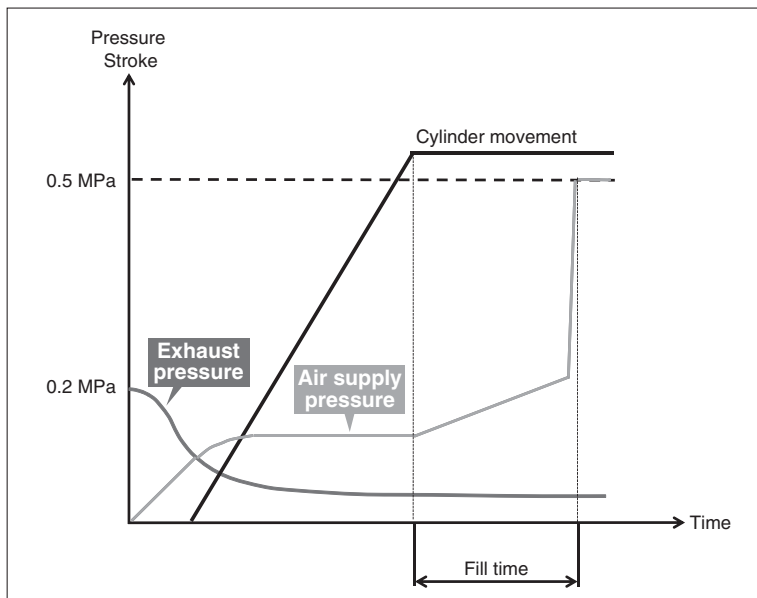

Figure 2. Fill Time Diagram



Air Saving Speed Controller with Pressure Reduction Function/ with Rapid Supply and Exhaust Function

RoHS

AS-R/AS-Q Series

Model

Model	Port size	Applicable tubing O.D.									
		Metric size (Applicable thread: R, G)				Inch size (Applicable thread: NPT)					
		6	8	10	12	1/4"	5/16"	3/8"	1/2"		
AS22R-□01-□	—	1/8	●	●	●			●	●		
AS22R-□02-□	AS22Q-□02-□	1/4	●	●	●			●	●		
AS32R-□02-□	AS32Q-□02-□	1/4	●	●	●			●	●	●	
AS32R-□03-□	AS32Q-□03-□	3/8	●	●	●			●	●	●	
AS42R-□03-□	AS42Q-□03-□	3/8			●	●			●	●	●
AS42R-□04-□	AS42Q-□04-□	1/2			●	●			●	●	●

Flow Direction Symbols on Body

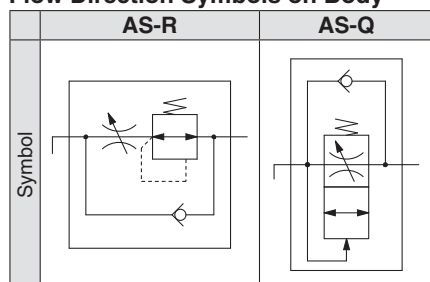

Specifications

Item	With pressure reduction function AS-R	With rapid supply and exhaust function AS-Q
Fluid	Air	
Proof pressure	1.05 MPa	
Maximum operating pressure	0.7 MPa	
Minimum operating pressure	0.3 MPa	
Set pressure	0.2 MPa	—
(Supply pressure at 0.5 MPa)	—	0.2 MPa
Set pressure for pressure reduction function	—	—
Minimum pressure for rapid supply function initiation	—	0.2 MPa
Ambient and fluid temperature	-5 to 60°C (No freezing)	
Applicable tubing material	Nylon, Soft nylon, Polyurethane*1 FEP, PFA	

*1 Use caution at the maximum operating pressure when using soft nylon or polyurethane tubing.
(For details, refer to the **Web Catalogue**.)

Caution

Be sure to read this before handling the products. Refer to the back cover for safety instructions. For flow control equipment precautions, refer to the "Handling Precautions for SMC Products" and the "Operation Manual" on the SMC website: <http://www.smc.eu>

Sonic Conductance and Critical Pressure Ratio for Air Saving Speed Controllers

With Pressure Reduction Function: AS-R Series

Model	AS22R-01 AS22R-02		AS32R-02 AS32R-03			AS42R-03 AS42R-04		
	Metric size	Ø 6 Ø 8 Ø 10	Ø 6	Ø 8	Ø 10	Ø 10	Ø 12	
Tubing O.D.	Inch size	Ø 1/4"	Ø 5/16"	Ø 1/4"	Ø 5/16"	Ø 3/8"	Ø 3/8"	Ø 1/2"
C values: Sonic conductance dm ³ /(s·bar)	Free flow	1.0	1.4	1.1	1.8	2.2	3.2	3.6
	Controlled flow	0.3		0.5			1.0	
b values: Critical pressure ratio	Free flow	0.3	0.2	0.3	0.2		0.3	
	Controlled flow	0.3	0.4	0.4			0.4	

* C and b values are for controlled flow with the needle fully open and free flow with the needle fully closed.

With Rapid Supply and Exhaust Function: AS-Q Series

Model	AS22Q-02		AS32Q-02 AS32Q-03			AS42Q-03 AS42Q-04		
	Metric size	Ø 6 Ø 8 Ø 10	Ø 6	Ø 8	Ø 10	Ø 10	Ø 12	
Tubing O.D.	Inch size	Ø 1/4"	Ø 5/16"	Ø 1/4"	Ø 5/16"	Ø 3/8"	Ø 3/8"	Ø 1/2"
C values: Sonic conductance dm ³ /(s·bar)	Free flow	1.0	1.4	1.1	1.8	2.2	3.2	3.6
	Controlled flow	0.2		0.6			0.9	
b values: Critical pressure ratio	Free flow	0.4	0.3	0.4	0.3	0.2	0.3	
	Controlled flow	0.6		0.6			0.5	0.6

* C and b values are for controlled flow with the needle fully open and free flow with the needle fully closed.

How to Order



With pressure reduction function

* Knob colour: White

With pressure reduction function



With rapid supply and exhaust function

* Knob colour: Light blue

With rapid supply and exhaust function

AS 2 2 R - [] 02 - 06

AS 2 2 Q - [] 02 - 06

Port size

01	1/8
02	1/4
03	3/8
04	1/2

Body size

2	1/4 standard
3	3/8 standard
4	1/2 standard

Applicable tubing O.D.

06	Ø 6	07	Ø 1/4"
08	Ø 8	09	Ø 5/16"
10	Ø 10	11	Ø 3/8"
12	Ø 12	13	Ø 1/2"

* For selecting applicable tubing O.D., refer to the model on page 9. Metric size and inch size types can be visually identified by the colour of the release button.
Metric size: Light grey
Inch size: Orange

Elbow

Thread type

—	R
N	NPT
G	G

* Thread type R and NPT are applied with sealant. Thread type G adopts face seal method.

Port size

02	1/4
03	3/8
04	1/2

* Only meter-in type is available. The meter-out version is not available and therefore is not shown in this How to Order.

AS-R/AS-Q Series

Flow Rate Characteristics

* The flow rate characteristics are representative values.

With Pressure Reduction Function: AS-R Series (Inlet pressure: 0.5 MPa)

AS22R

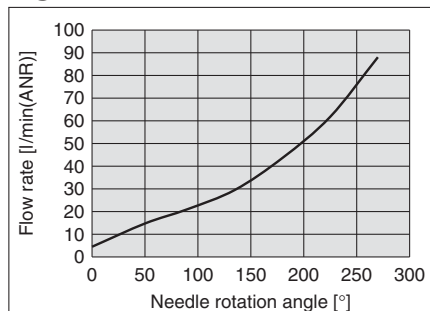

AS32R

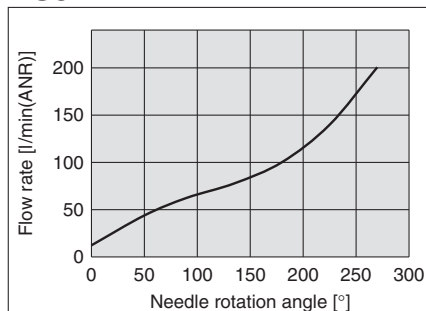

AS42R

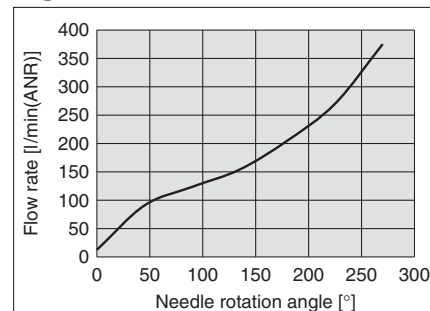

With Rapid Supply and Exhaust Function: AS-Q Series (Inlet pressure: 0.5 MPa)

AS22Q

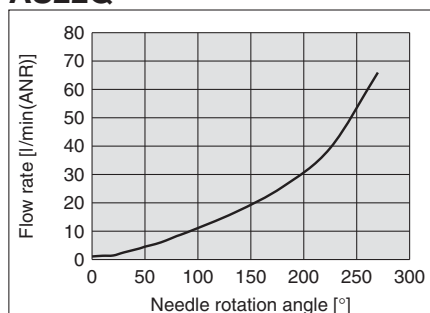

AS32Q

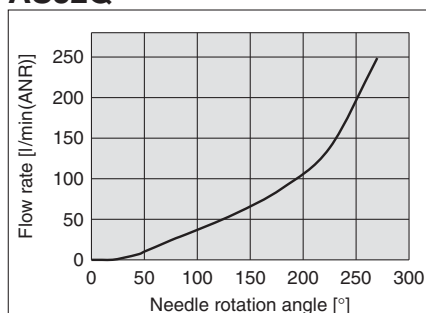

AS42Q

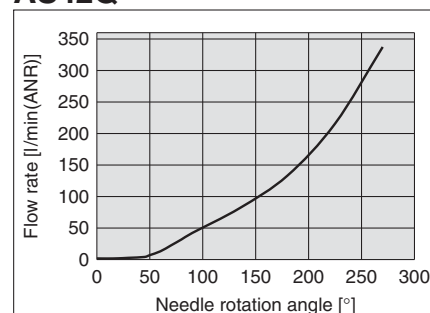

Pressure Characteristics (AS-R)

* AS-Q does not have a pressure reduction function. The pressure characteristics are not applicable.

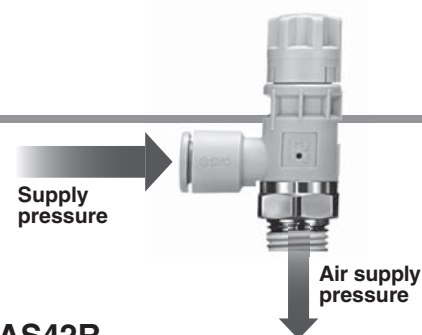

AS22R

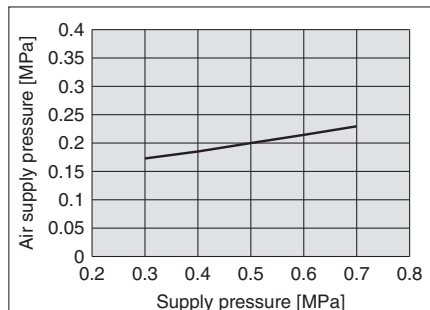

AS32R

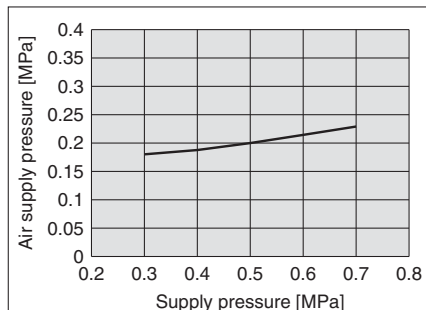

AS42R

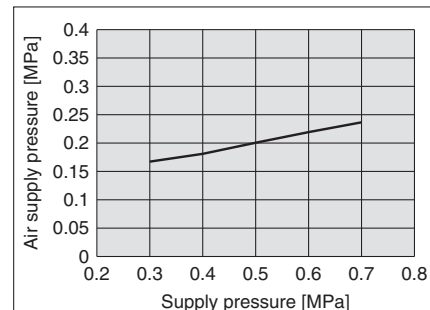

Cylinder Speed at Maximum Needle Rotation Angle (Guide)

Unit: mm/s

Cylinder bore size [mm]	Port size	AS22□	AS32□	AS42□
Ø 50	1/4	220	350	—
Ø 80	3/8	—	240	330
Ø 100	1/2	—	—	220

- Measurement conditions
- Cylinder stroke : 150 mm
- Supply pressure : 0.5 MPa
- Needle rotation angle: 270°
- Load : None
- Mounting orientation : Horizontal

* The values shown above are representative and not guaranteed.

As this product is the meter-in control type, it can be operated with less flow rate than the current (meter-out control) type.

[Example]

Supply pressure: 0.5 MPa

When the internal pressure of the tube during cylinder operation with meter-in control is 0.2 MPa, the same cylinder speed can be obtained with half the flow in case of meter-out control.

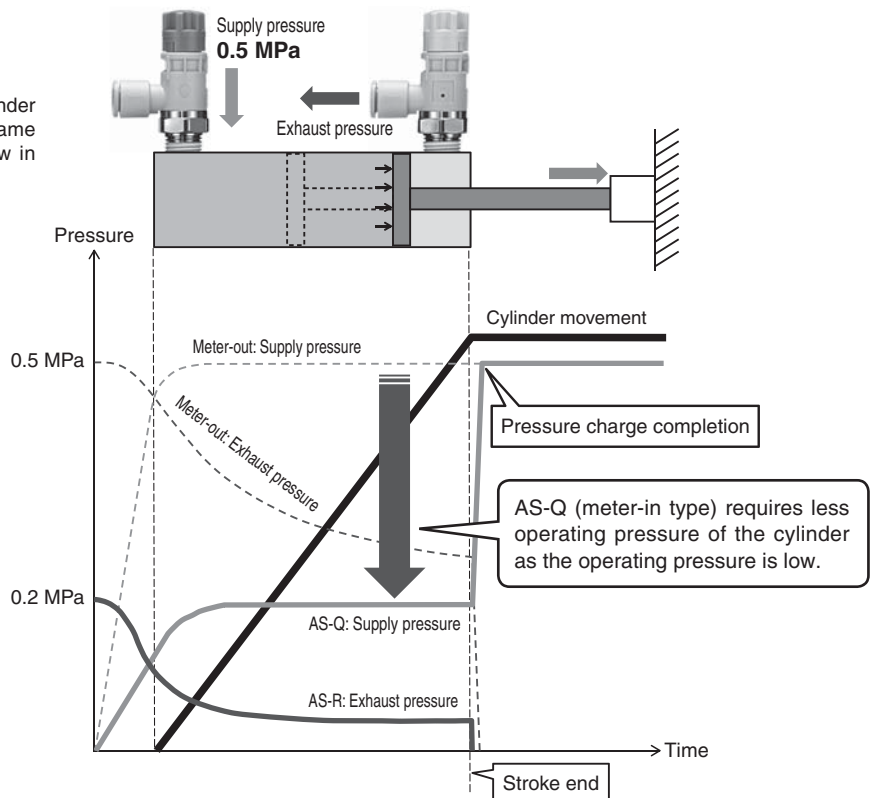

AS-R/AS-Q Series

Construction

Seal method: Sealant
For R, NPT thread

AS-R

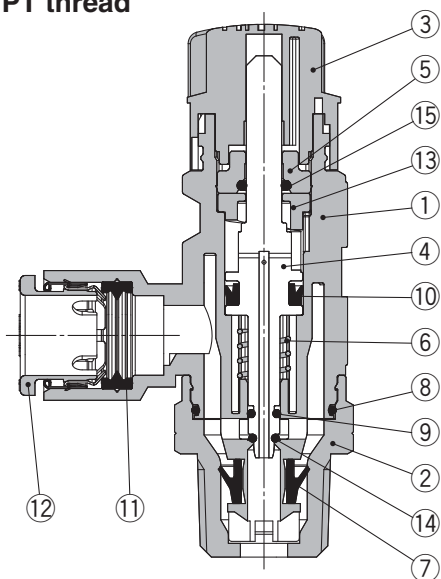

AS-Q

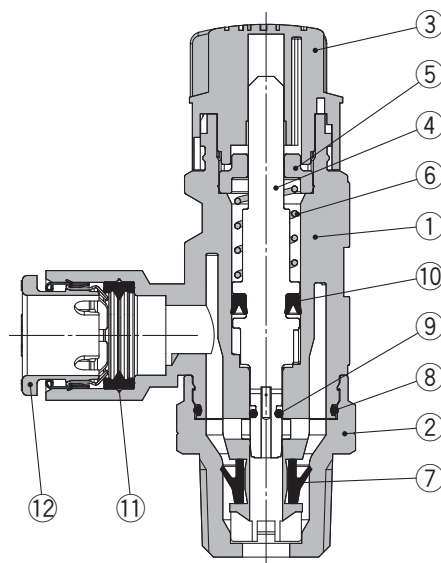

Seal method: Face seal
For G thread

AS-R

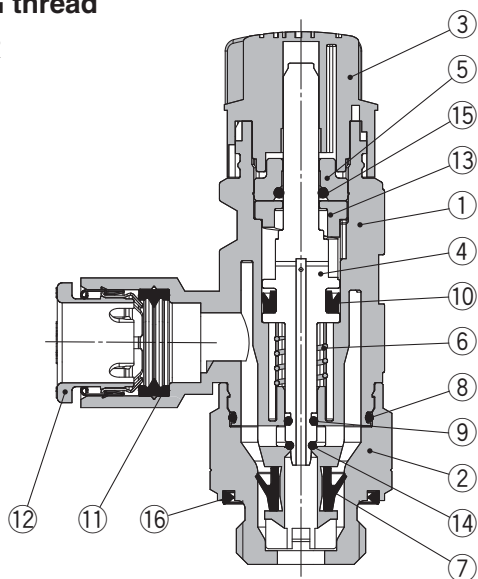

AS-Q

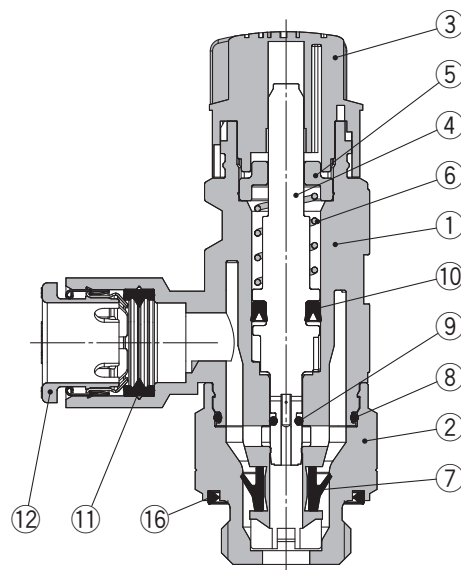

Component Parts

No.	Description	Material	Note
1	Body A	PBT	
2	Body B	Brass	Electroless nickel plating
3	Knob	POM	
4	Needle	POM	
5	End cover	Brass	Electroless nickel plating
6	Spring	Steel wire	
7	U-seal	HNBR	
8	O-ring	NBR	
9	Needle O-ring	NBR	
10	Y-seal	NBR	
11	Seal for fitting	NBR	
12	Cassette	—	
13	Stator	POM	
14	Valve O-ring	HNBR	
15	Shaft O-ring	NBR	
16	Seal	NBR	

Dimensions: AS-R

Seal method: Sealant
For R, NPT thread

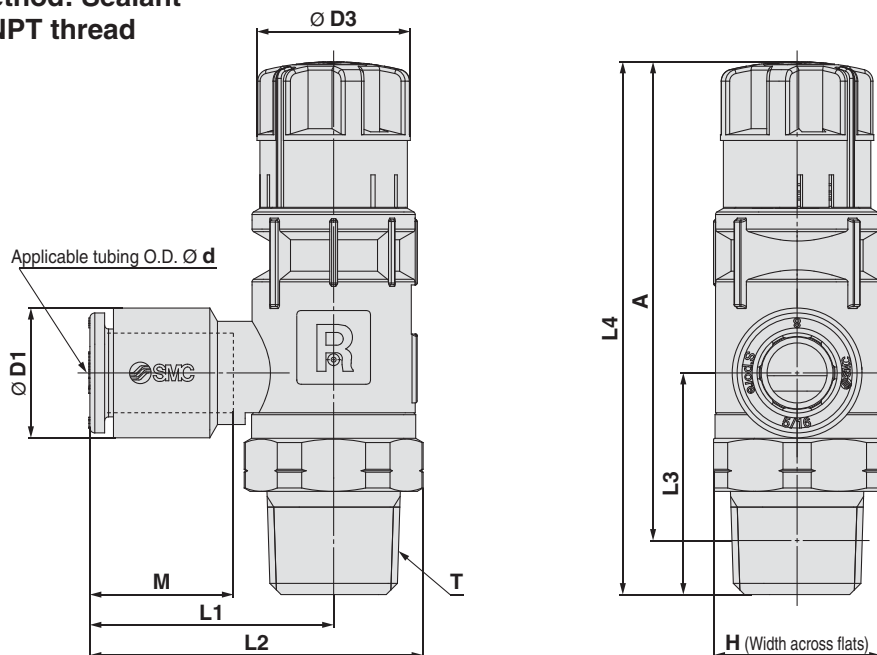

* The release button of Ø 6 One-touch fitting is oval as shown above. The button can be rotated freely.

Metric Size

Model	d	T	H	D1	D3	L1	L2	L3	L4*1		A*2		M	Weight [g]
									Max.	Min.	Max.	Min.		
AS22R-01-06	6	1/8	13	11.2	15.6 (15.9)	24.1	32.5	27.1	60.3	58.7	57.1	55.5	13.3	26
AS22R-01-08	8			13.2		24.8	33.2						14.2	26
AS22R-01-10	10			15.9		28.2	36.6						15.6	28
AS22R-02-06	6	1/4	17	11.2	15.6 (15.9)	24.1	33.4	22.6	55.8	54.2	50.3	48.7	13.3	25
AS22R-02-08	8			13.2		24.8	34.1						14.2	26
AS22R-02-10	10			15.9		28.2	37.5						15.6	27
AS32R-02-06	6	1/4	19	10.4	18.3 (18.7)	22	32.3	36.4	73.8	72.2	68.3	66.7	13.3	48
AS32R-02-08	8			13.2		23.6	33.9						14.2	49
AS32R-02-10	10			15.9		28	38.3						15.6	50
AS32R-03-06	6	3/8	19	10.4	18.3 (18.7)	22	32.3	28.7	66.1	64.5	60.9	59.3	13.3	41
AS32R-03-08	8			13.2		23.6	33.9						14.2	41
AS32R-03-10	10			15.9		28	38.3						15.6	42
AS42R-03-10	10	3/8	24	15.9	23.5 (23.9)	28.2	41.1	46	89.4	87.8	84.2	82.6	15.6	98
AS42R-03-12	12			19.3		32.3	45.2	44.9					17	100
AS42R-04-10	10	1/2	24	15.9	23.5 (23.9)	28.2	41.1	36.2	79.6	78	72.5	70.9	15.6	76
AS42R-04-12	12			19.3		32.3	45.2	35.1					17	78

*1 Reference dimensions

*2 Reference dimensions of threads after installation

* The () D3 dimension is the maximum value.

Inch Size

Model	d	T	H	D1	D3	L1	L2	L3	L4*1		A*2		M	Weight [g]
									Max.	Min.	Max.	Min.		
AS22R-N01-07	1/4"	1/8	12.7	11.2	15.6 (15.9)	24.1	32.5	27.1	60.3	58.7	57.1	55.5	13.3	26
AS22R-N01-09	5/16"			13.2		24.8	33.2						14.2	26
AS22R-N02-07	1/4"	1/4	17.5	11.2	15.6 (15.9)	24.1	33.5	22.6	55.8	54.2	50.3	48.7	13.3	26
AS22R-N02-09	5/16"			13.2		24.8	34.2						14.2	26
AS32R-N02-09	5/16"	1/4	19	13.2	18.3 (18.7)	23.6	33.9	36.4	73.8	72.2	68.3	66.7	14.2	51
AS32R-N02-11	3/8"			15.9		28	38.3	35.7					15.6	52
AS32R-N03-09	5/16"	3/8	19	13.2	18.3 (18.7)	23.6	33.9	28.7	66.1	64.5	60.9	59.3	14.2	42
AS32R-N03-11	3/8"			15.9		28	38.3	28					15.6	43
AS42R-N03-11	3/8"	3/8	23.8	15.9	23.5 (23.9)	28.2	41	46	89.4	87.8	84.2	82.6	15.6	97
AS42R-N03-13	1/2"			19.3		32.3	45.1	44.9					17	99
AS42R-N04-11	3/8"	1/2	23.8	15.9	23.5 (23.9)	28.2	41	36.2	79.6	78	72.5	70.9	15.6	75
AS42R-N04-13	1/2"			19.3		32.3	45.1	35.1					17	77

*1 Reference dimensions

*2 Reference dimensions of threads after installation

* The () D3 dimension is the maximum value.

AS-R/AS-Q Series For R, NPT thread

Dimensions: AS-Q

Seal method: Sealant
For R, NPT thread

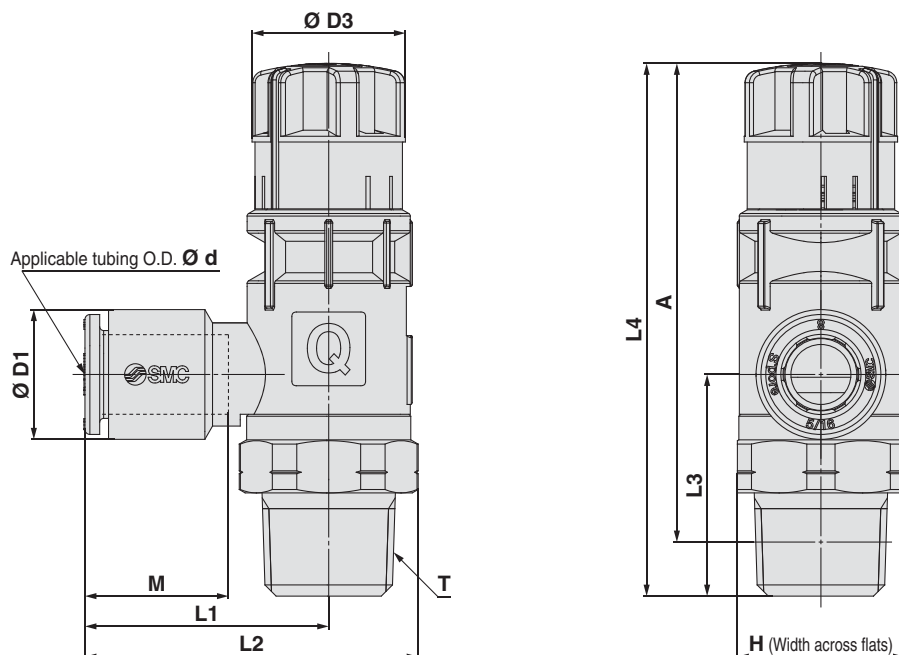

* The release button of $\varnothing 6$ One-touch fitting is oval as shown above. The button can be rotated freely.

Metric Size

Model	d	T	H	D1	D3	L1	L2	L3	L4* ¹		A* ²		M	Weight [g]
									Max.	Min.	Max.	Min.		
AS22Q-02-06	6	1/4	17	11.2	15.6 (15.9)	24.1	33.4	22.6	55.8	54.2	50.3	48.7	13.3	25
AS22Q-02-08	8			24.8		34.1	14.2						26	
AS22Q-02-10	10			28.2		37.5	15.6						27	
AS32Q-02-06	6	1/4	19	10.4	18.3 (18.7)	22	32.3	36.4	73.8	72.2	68.3	66.7	13.3	48
AS32Q-02-08	8			23.6		33.9	14.2						48	
AS32Q-02-10	10			28		38.3	15.6						49	
AS32Q-03-06	6	3/8	19	10.4	18.3 (18.7)	22	32.3	28.7	66.1	64.5	60.9	59.3	13.3	40
AS32Q-03-08	8			23.6		33.9	14.2						41	
AS32Q-03-10	10			28		38.3	15.6						42	
AS42Q-03-10	10	3/8	24	15.9	23.5 (23.9)	28.2	41.1	46	89.4	87.8	84.2	82.6	15.6	97
AS42Q-03-12	12			32.3		45.2	44.9	17					100	
AS42Q-04-10	10	1/2	24	15.9	23.5 (23.9)	28.2	41.1	36.2	79.6	78	72.5	70.9	15.6	76
AS42Q-04-12	12			32.3		45.2	35.1	17					78	

*1 Reference dimensions

*2 Reference dimensions of threads after installation

* The () D3 dimension is the maximum value.

Inch Size

Model	d	T	H	D1	D3	L1	L2	L3	L4* ¹		A* ²		M	Weight [g]
									Max.	Min.	Max.	Min.		
AS22Q-N02-07	1/4"	1/4	17.5	11.2	15.6 (15.9)	24.1	33.5	22.6	55.8	54.2	50.3	48.7	13.3	26
AS22Q-N02-09	5/16"			13.2		34.2	14.2						26	
AS32Q-N02-09	5/16"	1/4	19	13.2	18.3 (18.7)	23.6	33.9	36.4	73.8	72.2	68.3	66.7	14.2	50
AS32Q-N02-11	3/8"			15.9		28	38.3	35.7					15.6	52
AS32Q-N03-09	5/16"	3/8	19	13.2	18.3 (18.7)	23.6	33.9	28.7	66.1	64.5	60.9	59.3	14.2	42
AS32Q-N03-11	3/8"			15.9		28	38.3	28					15.6	43
AS42Q-N03-11	3/8"	3/8	23.8	15.9	23.5 (23.9)	28.2	41	46	89.4	87.8	84.2	82.6	15.6	97
AS42Q-N03-13	1/2"			19.3		32.3	45.1	44.9					17	99
AS42Q-N04-11	3/8"	1/2	23.8	15.9	23.5 (23.9)	28.2	41	36.2	79.6	78	72.5	70.9	15.6	75
AS42Q-N04-13	1/2"			19.3		32.3	45.1	35.1					17	76

*1 Reference dimensions

*2 Reference dimensions of threads after installation

* The () D3 dimension is the maximum value.

Dimensions: AS-R

Seal method: Face seal
For G thread

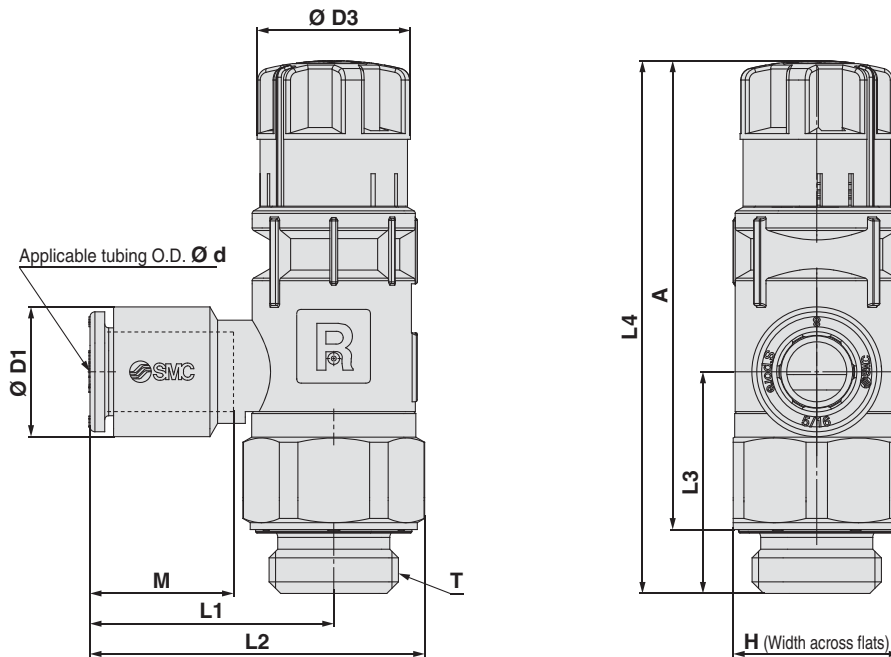

* The release button of $\varnothing 6$ One-touch fitting is oval as shown above. The button can be rotated freely.

Metric Size

Model	d	T	H	D1	D3	L1	L2	L3	L4* ¹		A* ²		M	Weight [g]
									Max.	Min.	Max.	Min.		
AS22R-G01-06	6	1/8	13	11.2	15.6 (15.9)	24.1	32.5	27.5	60.7	59.1	55.2	53.6	13.3	28
AS22R-G01-08	8			13.2		24.8	33.2						14.2	28
AS22R-G01-10	10			15.9		28.2	36.6						15.6	29
AS22R-G02-06	6	1/4	17	11.2	15.6 (15.9)	24.1	33.4	22.6	55.8	54.2	49.3	47.7	13.3	28
AS22R-G02-08	8			13.2		24.8	34.1						14.2	28
AS22R-G02-10	10			15.9		28.2	37.5						15.6	29
AS32R-G02-06	6	1/4	21	10.4	18.3 (18.7)	22	33.2	36.4	73.8	72.2	67.3	65.7	13.3	60
AS32R-G02-08	8			13.2		23.6	34.8						14.2	61
AS32R-G02-10	10			15.9		28	39.2						15.6	62
AS32R-G03-06	6	3/8	21	10.4	18.3 (18.7)	22	33.2	28.7	66.1	64.5	58.6	57	13.3	48
AS32R-G03-08	8			13.2		23.6	34.8						14.2	49
AS32R-G03-10	10			15.9		28	39.2						15.6	50
AS42R-G03-10	10	3/8	27	15.9	23.5	28.2	42.6	46	89.4	87.8	81.9	80.3	15.6	116
AS42R-G03-12	12			19.3	32.3	46.7	44.9	17					118	
AS42R-G04-10	10	1/2	27	15.9	23.5	28.2	42.6	36.2	79.6	78	70.6	69	15.6	93
AS42R-G04-12	12			19.3	32.3	46.7	35.1	17					95	

*1 Reference dimensions

*2 Reference dimensions of threads after installation

* The () D3 dimension is the maximum value.

AS-R/AS-Q Series For G thread

Dimensions: AS-Q

Seal method: Face seal
For G thread

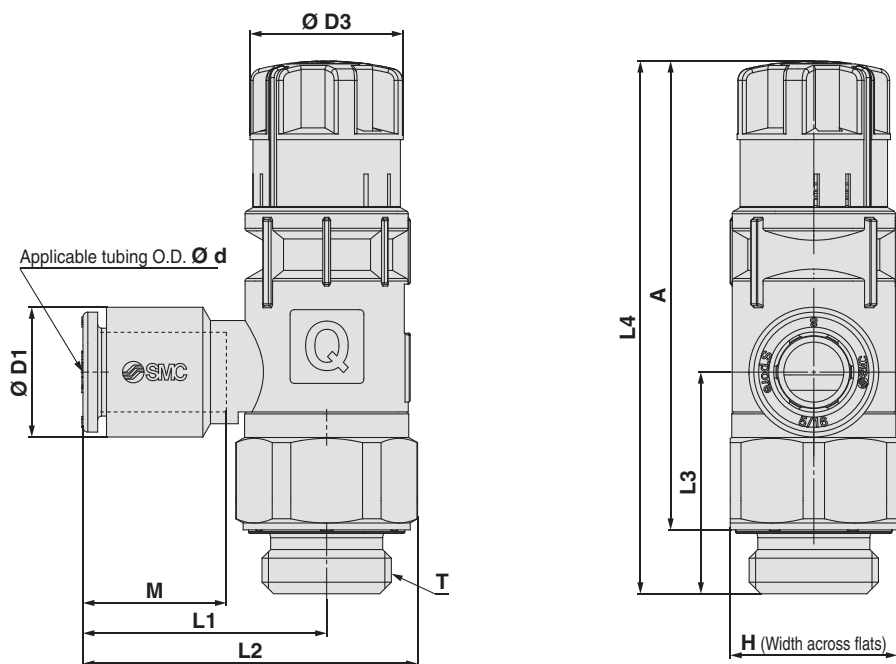

* The release button of $\varnothing 6$ One-touch fitting is oval as shown above. The button can be rotated freely.

Metric Size

Model	d	T	H	D1	D3	L1	L2	L3	L4*1		A*2		M	Weight [g]
									Max.	Min.	Max.	Min.		
AS22Q-G02-06	6	1/4	17	11.2	15.6 (15.9)	24.1	33.4	22.6	55.8	54.2	49.3	47.7	13.3	28
AS22Q-G02-08	8			24.8		34.1	14.2						28	
AS22Q-G02-10	10			28.2		37.5	15.6						29	
AS32Q-G02-06	6	1/4	21	10.4	18.3 (18.7)	22	33.2	36.4	73.8	72.2	67.3	65.7	13.3	60
AS32Q-G02-08	8			23.6		34.8	14.2						60	
AS32Q-G02-10	10			28		39.2	35.7						15.6	61
AS32Q-G03-06	6	3/8	21	10.4	18.3 (18.7)	22	33.2	28.7	66.1	64.5	58.6	57	13.3	48
AS32Q-G03-08	8			23.6		34.8	14.2						49	
AS32Q-G03-10	10			28		39.2	28						15.6	50
AS42Q-G03-10	10	3/8	27	15.9	23.5 (23.9)	28.2	42.6	46	89.4	87.8	81.9	80.3	15.6	115
AS42Q-G03-12	12			32.3		46.7	44.9						17	117
AS42Q-G04-10	10	1/2	27	15.9	23.5 (23.9)	28.2	42.6	36.2	79.6	78	70.6	69	15.6	92
AS42Q-G04-12	12			32.3		46.7	35.1						17	94

*1 Reference dimensions

*2 Reference dimensions of threads after installation

* The () D3 dimension is the maximum value.

Pressure Time Chart

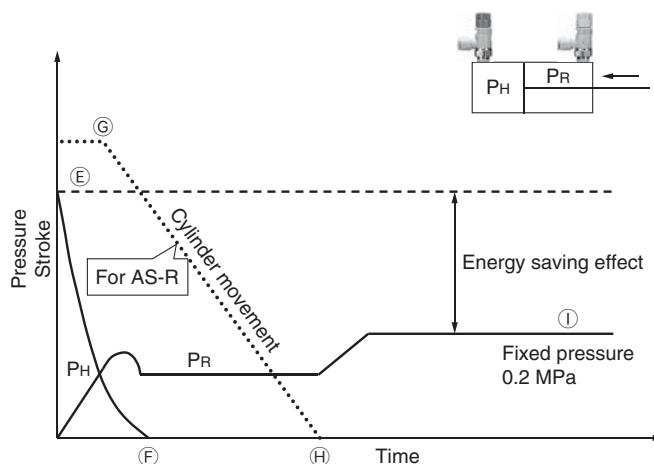
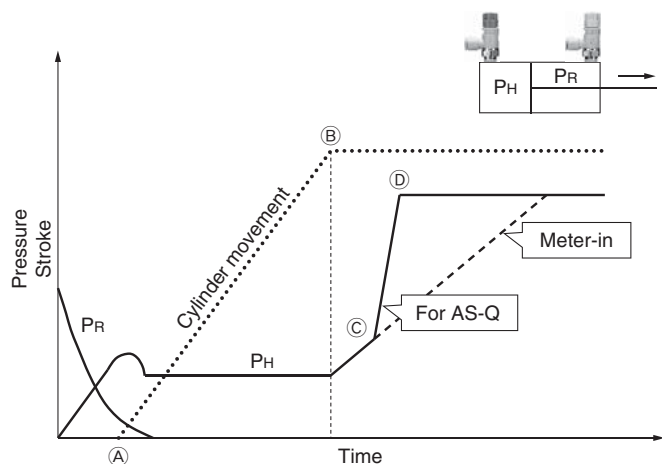

○ Working stroke pressure/Stroke change

Along the pressure supply, the piston moves from **A** to **B**. When the piston reaches **B**, the head pressure (**PH**) **increases rapidly** from **C** to **D**.

○ Return stroke pressure/Stroke change

To reduce the loss of time due to pressure difference, the head pressure (**PH**) is exhausted rapidly from **E** to **F**, moving the piston from **G** to **H**. The rod pressure (**PR**) **decreases to I** by the built-in pressure reduction function. This reduces air consumption by the amount of difference between supply pressure **E** and the differential pressure.

Construction Principle

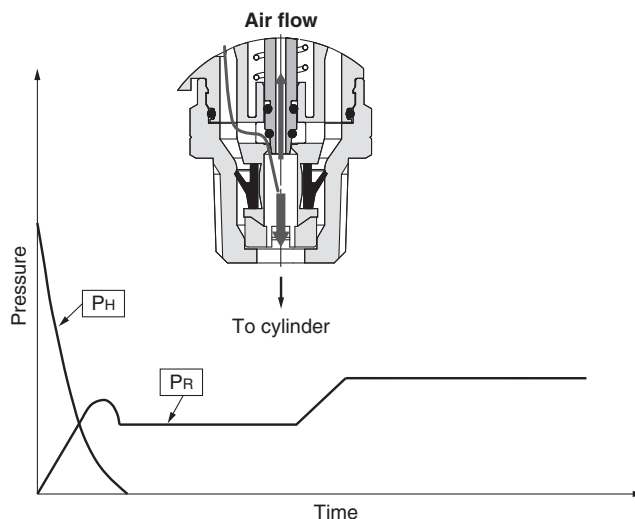
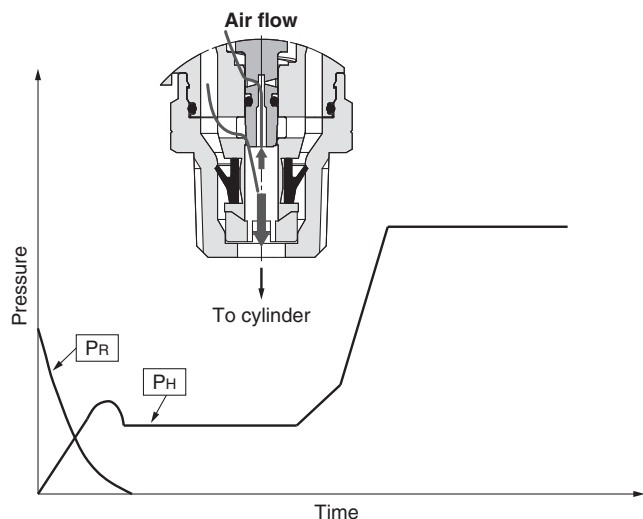
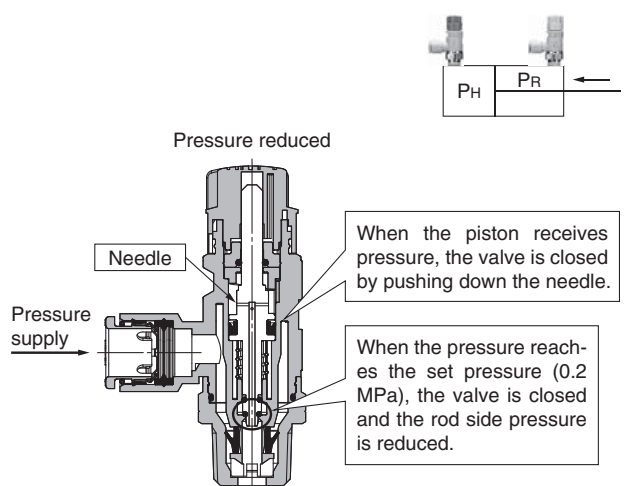
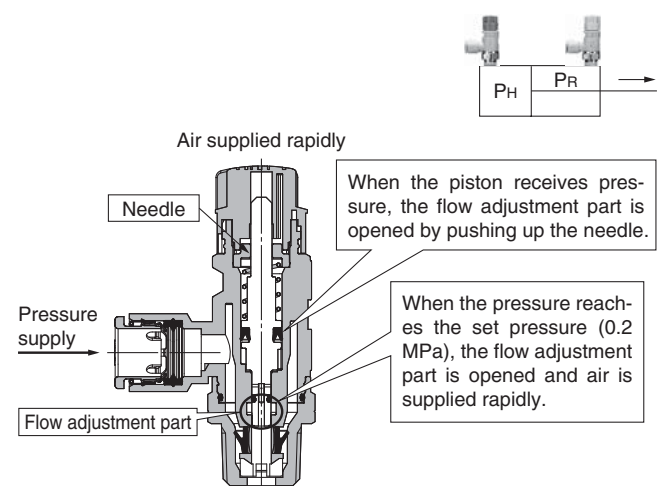

Difference between Meter-in and Meter-out Control

1 Meter-out Control

Advantages

- Easy to adjust the speed.
- Speed is stabilised for the fluctuation of the load.
- Vertical control is available.

Disadvantages

- Compressed air on exhaust side is required (causing sudden extension).
- Regardless of the weight of the load, 100 % of supply pressure is supplied during the movement of the cylinder. Air which is unnecessary for the load weight is consumed.

Caution

Make sure that compressed air is present at the exhaust side when starting the operation of the cylinder. Operation without compressed air at the exhaust side causes sudden extension.

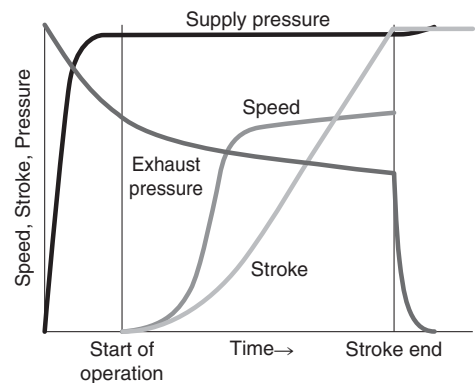

Feature of meter-out control

2 Meter-in Control

Advantages

- Not effected by exhaust condition.
- Operation starts quickly.
- Supply pressure depending on the weight load is supplied during the movement of the cylinder. Only air which is necessary for the load weight is consumed.

Disadvantages

- Susceptible for the changes in the load.
- Susceptible to the external or inertia force. Vertical control is difficult.
- Adiabatic expansion due to rapid exhaust of air may form dew in the cylinder.
- Use of air cushion is difficult.

Caution

Preventive measure against dew formation is necessary when compressed air is supplied.

For details, refer to the "Precautionary measures against condensation in a pneumatic system" in the **Web Catalogue**.

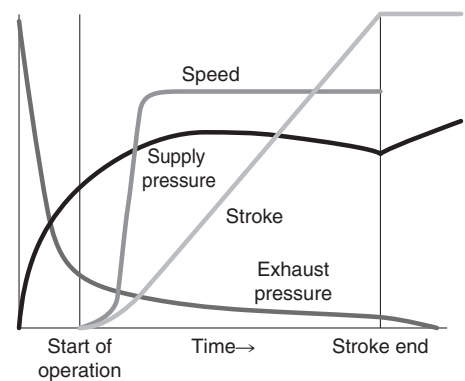

Feature of meter-in control

Sudden extension...

When compressed air is not present at the exhaust side or pressure is lower than the supply pressure for meter-out circuit, orifice control is unavailable, making the actuator operate rapidly. There is no sudden extension usually for meter-in circuits.



AS-R/AS-Q Series Specific Product Precautions 1

Be sure to read this before handling the products. Refer to the back cover for safety instructions. For flow control equipment precautions, refer to the “Handling Precautions for SMC Products” and the “Operation Manual” on the SMC website: <http://www.smc.eu>

Design and Selection

Warning

1. Check the specifications.

The products in this catalog are designed to be used in compressed air systems (including vacuum) only.

If the products are used in an environment where pressure or temperature is out of the specified range, damage and/or malfunction may result. Do not use under such conditions. (Refer to the specifications.)

Please contact SMC when using a fluid other than compressed air (including vacuum).

We do not guarantee against any damage if the product is used outside of the specification range.

2. The products in this catalogue are not designed for the use as stop valve with zero air leakage.

A certain amount of leakage is allowed in the product's specifications. Tightening the needle to reduce leakage to zero may result in equipment damage.

3. Do not disassemble the product or make any modifications, including additional machining.

It may cause human injury and/or an accident.

4. The flow rate characteristics for each product are representative values.

The flow rate characteristics are characteristics of each individual product. Actual values may differ depending on the piping, circuitry, pressure conditions, etc.

5. Sonic conductance (C) and critical pressure ratio (b) values for products are representative values.

The speed controller's controlled flow values are with the needle fully open and free flow with the needle fully closed.

6. Check if PTFE can be used in application.

PTFE powder (Polytetrafluoroethylene resin) is included in the seal material for piping taper thread of male thread type. Confirm that the use of it will not cause any adverse effect on the system. Please contact SMC if the Safety Data Sheet (SDS) is required.

7. Regarding cylinders

The AS-Q series cannot be used in combination with the cylinders listed in the chart as there is a chance that such cylinders will lurch. As for the CLQ series and the CQ2 series, use with a rubber bumper.

Cylinders that cannot be used
JCQ Series
RQ Series
RLQ Series

Mounting

Warning

1. Operation Manual

Install the products and operate them only after reading the Operation Manual carefully and understanding its contents. Also, keep the Operation Manual where it can be referred to as necessary.

2. Ensure sufficient space for maintenance activities.

When installing the products, allow access for maintenance.

3. Tighten threads with the proper tightening torque.

When installing the products, follow the listed proper torque.

Mounting

Warning

4. After pushing the knob down to lock, confirm that it is locked.

It should not be possible to rotate the knob to the right or to the left. If the knob is pulled with force, it may break. Do not pull the knob with excessive force.



Locked



Unlocked

5. Check the rotation angle of the knob.

Rotation angle is 270 degrees. The knob cannot be rotated more than this. Excessive rotation will cause damage to the product. Check the rotation angle before using the product.

Marker for fully closed position

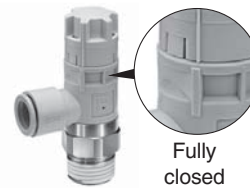

Fully closed

Marker for fully open position

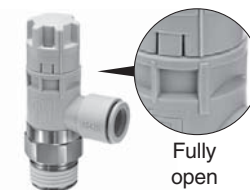

Fully open

Knob operation range

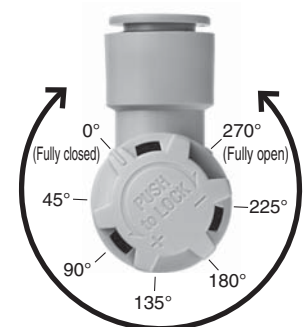

Adjustment can be made every 45 degrees.

6. Do not use tools such as pliers to rotate the knob.

It can cause idle rotation of the knob or damage.

7. Verify the air flow direction.

Mounting backward is dangerous, because the speed adjustment needle will not work and the actuator may lurch suddenly.

8. Adjust the speed by opening the needle slowly from the fully closed state.

Loose needle valves may cause unexpected sudden actuator lurching.

When a needle valve is turned clockwise, it is closed and actuator speed decreases. When a needle valve is turned counter-clockwise, it is open and actuator speed increases.

9. Do not apply excessive force or shock to the body or fittings with an impact tool.

It can cause damage or air leakage.

10. Refer to the fittings & tubing precautions in the Best Pneumatics catalogue for handling One-touch fittings.



AS-R/AS-Q Series Specific Product Precautions 2

Be sure to read this before handling the products. Refer to the back cover for safety instructions. For flow control equipment precautions, refer to the "Handling Precautions for SMC Products" and the "Operation Manual" on the SMC website: <http://www.smc.eu>

Mounting

Warning

11. To install/remove the product, use an appropriate wrench to tighten/loosen at the supplied nut on body B.

Do not apply torque at other points as the product may be damaged. Rotate body A manually for positioning after installation.

12. Do not use body A for applications involving continuous rotation.

Body A and the fitting section may be damaged.

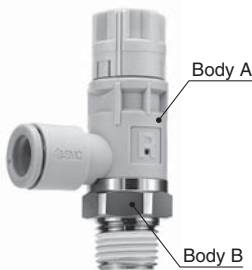

Caution

1. This product has a stopper for fully closed/fully open in rotating direction. Excess torque may break the stopper. Table below shows the maximum allowable torque of the knob.

Body size	Max. allowable torque [N·m]
2	0.07
3	0.13
4	0.25



2. When performing the piping work, turn the tightening tool in the horizontal direction to the hexagon across flats of the body B so that any moment is not applied to the body A. If the tool is in contact with the body A, this may cause the body B to come off.

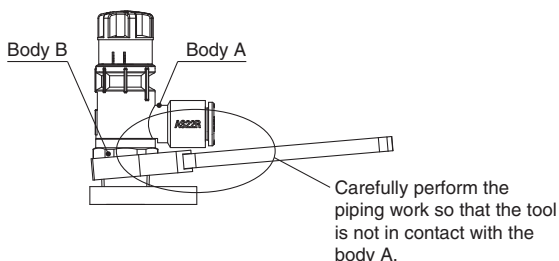

Caution

For R, NPT Thread (With sealant)

Tightening method

1. The proper tightening torques of the fittings are as shown in the table below. As a guide, tighten it by hand, then turn it two or three turns with a wrench. Check the dimensions of each product for the hexagon width across flats.

Connection thread size	Proper tightening torque [N·m]
NPT, R1/8	3 to 5
NPT, R1/4	8 to 12
NPT, R3/8	15 to 20
NPT, R1/2	20 to 25

Chamfered area for female thread

By chamfering as shown in the table below, machining of threads is easier and effective for burr prevention.

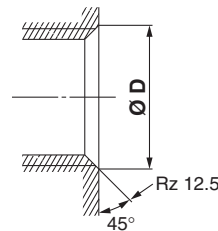

Connection thread size	Chamfered dimension Ø D (Recommended value)	
	Rc	NPT, NPTF
1/8	10.2 to 10.4	10.5 to 10.7
1/4	13.6 to 13.8	14.1 to 14.3
3/8	17.1 to 17.3	17.4 to 17.6
1/2	21.4 to 21.6	21.7 to 21.9

* For Uni thread, Rz 12.5 is necessary for sealing at the chamfered part.

For G Thread (Face seal)

Tightening method

First, tighten the threaded portion by hand, then use a proper wrench, which could be suitable for the width across flats of the hexagon body, to tighten it further at a wrench tightening angle shown in the table below. For a tightening torque guide, refer to the table below. Check the dimensions of each product for the hexagon width across flats.

Connection thread size	Wrench tightening angle after hand-tightening (deg)	Proper tightening torque [N·m]
G1/8	10 to 20	3 to 4
G1/4	15 to 35	4 to 5
G3/8	15 to 35	8 to 9
G1/2	15 to 35	14 to 15

Chamfered area for female thread (Recommended value)

1. Conforming to ISO 16030-2001, the chamfered dimensions shown in the table below are recommended. By chamfering as shown in the table below, machining of threads is easier and effective for burr prevention.

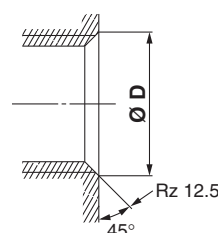

Nominal thread size	Chamfered dimension Ø D	
	Min.	Max.
1/8	9.8	10.2
1/4	13.3	13.7
3/8	16.8	17.2
1/2	21.0	21.4

2. Use G external threads with G internal threads.



AS-R/AS-Q Series Specific Product Precautions 3

Be sure to read this before handling the products. Refer to the back cover for safety instructions. For flow control equipment precautions, refer to the "Handling Precautions for SMC Products" and the "Operation Manual" on the SMC website: <http://www.smc.eu>

Adjustment

Warning

1. Adjust the knob with no pressure being supplied to the product.

If the adjustment is carried out on the pressurised product, it may cause idle rotation of the knob or a breakage of the internal components.

Example) When the product mounted on the head side is adjusted:

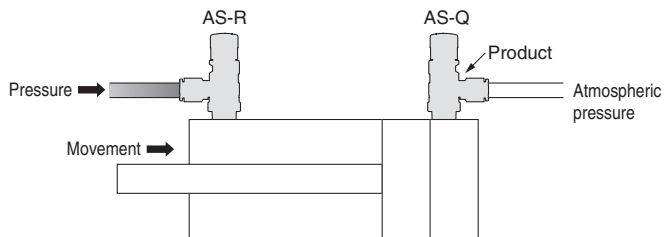

When the product mounted on the rod side is adjusted:

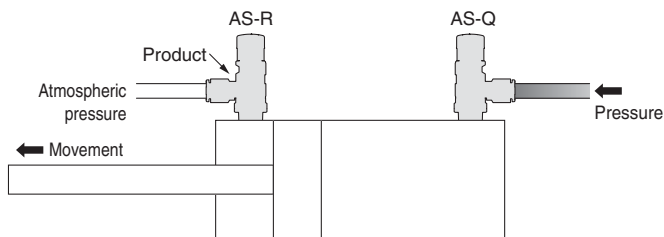

* Adjust the product when the cylinder operates in the direction of the arrow or completes the operation.

Piping Threads with Sealant

Caution

1. If the fitting is tightened with excessive torque, a large amount of sealant will seep out. Remove the excess sealant.
2. Insufficient tightening may loosen the threads, or cause air leakage.
3. Reuse
 - 1) Normally, fittings with a sealant can be reused up to 2 to 3 times.
 - 2) To prevent air leakage through the sealant, remove any loose sealant stuck to the fitting by blowing air over the threaded portion.
 - 3) If the sealant no longer provides effective sealing, wind sealing tape over the sealant before reusing. Do not use the sealant in any form other than a tape type.
 - 4) Normally, G thread (face seal) can be reused up to 6 to 10 times. Seals cannot be replaced.
4. Once the fitting has been tightened, backing it out to its original position often causes the sealant to become defective. Air leakage will occur.
5. Use R external threads with Rc internal threads and NPT external threads with NPT internal threads.

Piping

Caution

1. Refer to the fittings & tubing precautions in the Best Pneumatics catalogue for handling One-touch fittings.

2. Preparation before piping

Before piping is connected, it should be thoroughly blown out with air (flushing) or washed to remove chips, cutting oil and other debris from inside the pipe.

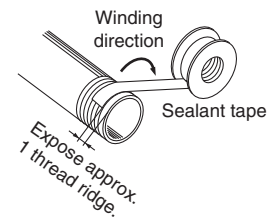

3. Winding of sealant tape

When screwing together pipes and fittings, etc., be certain that chips from the pipe threads and sealing material do not get inside the pipe. Also, when the sealant tape is used, leave approx. 1 thread ridge exposed at the end of the threads.



Safety Instructions

These safety instructions are intended to prevent hazardous situations and/or equipment damage. These instructions indicate the level of potential hazard with the labels of “Caution,” “Warning” or “Danger.” They are all important notes for safety and must be followed in addition to International Standards (ISO/IEC)*1), and other safety regulations.

-  **Caution:** Caution indicates a hazard with a low level of risk which, if not avoided, could result in minor or moderate injury.
-  **Warning:** Warning indicates a hazard with a medium level of risk which, if not avoided, could result in death or serious injury.
-  **Danger:** Danger indicates a hazard with a high level of risk which, if not avoided, will result in death or serious injury.

- *1) ISO 4414: Pneumatic fluid power – General rules relating to systems.
- ISO 4413: Hydraulic fluid power – General rules relating to systems.
- IEC 60204-1: Safety of machinery – Electrical equipment of machines. (Part 1: General requirements)
- ISO 10218-1: Manipulating industrial robots - Safety. etc.

Warning

- The compatibility of the product is the responsibility of the person who designs the equipment or decides its specifications.**
Since the product specified here is used under various operating conditions, its compatibility with specific equipment must be decided by the person who designs the equipment or decides its specifications based on necessary analysis and test results. The expected performance and safety assurance of the equipment will be the responsibility of the person who has determined its compatibility with the product. This person should also continuously review all specifications of the product referring to its latest catalogue information, with a view to giving due consideration to any possibility of equipment failure when configuring the equipment.
- Only personnel with appropriate training should operate machinery and equipment.**
The product specified here may become unsafe if handled incorrectly. The assembly, operation and maintenance of machines or equipment including our products must be performed by an operator who is appropriately trained and experienced.
- Do not service or attempt to remove product and machinery/equipment until safety is confirmed.**
 - The inspection and maintenance of machinery/equipment should only be performed after measures to prevent falling or runaway of the driven objects have been confirmed.
 - When the product is to be removed, confirm that the safety measures as mentioned above are implemented and the power from any appropriate source is cut, and read and understand the specific product precautions of all relevant products carefully.
 - Before machinery/equipment is restarted, take measures to prevent unexpected operation and malfunction.
- Contact SMC beforehand and take special consideration of safety measures if the product is to be used in any of the following conditions.**
 - Conditions and environments outside of the given specifications, or use outdoors or in a place exposed to direct sunlight.
 - Installation on equipment in conjunction with atomic energy, railways, air navigation, space, shipping, vehicles, military, medical treatment, combustion and recreation, or equipment in contact with food and beverages, emergency stop circuits, clutch and brake circuits in press applications, safety equipment or other applications unsuitable for the standard specifications described in the product catalogue.
 - An application which could have negative effects on people, property, or animals requiring special safety analysis.
 - Use in an interlock circuit, which requires the provision of double interlock for possible failure by using a mechanical protective function, and periodical checks to confirm proper operation.

Limited warranty and Disclaimer/ Compliance Requirements

The product used is subject to the following “Limited warranty and Disclaimer” and “Compliance Requirements”. Read and accept them before using the product.

Limited warranty and Disclaimer

- The warranty period of the product is 1 year in service or 1.5 years after the product is delivered, whichever is first.*2) Also, the product may have specified durability, running distance or replacement parts. Please consult your nearest sales branch.
- For any failure or damage reported within the warranty period which is clearly our responsibility, a replacement product or necessary parts will be provided. This limited warranty applies only to our product independently, and not to any other damage incurred due to the failure of the product.
- Prior to using SMC products, please read and understand the warranty terms and disclaimers noted in the specified catalogue for the particular products.

*2) Vacuum pads are excluded from this 1 year warranty. A vacuum pad is a consumable part, so it is warranted for a year after it is delivered. Also, even within the warranty period, the wear of a product due to the use of the vacuum pad or failure due to the deterioration of rubber material are not covered by the limited warranty.

Caution

- The product is provided for use in manufacturing industries.**
The product herein described is basically provided for peaceful use in manufacturing industries. If considering using the product in other industries, consult SMC beforehand and exchange specifications or a contract if necessary. If anything is unclear, contact your nearest sales branch.

Caution

- SMC products are not intended for use as instruments for legal metrology.**
- Measurement instruments that SMC manufactures or sells have not been qualified by type approval tests relevant to the metrology (measurement) laws of each country. Therefore, SMC products cannot be used for business or certification ordained by the metrology (measurement) laws of each country.

Safety Instructions

Be sure to read “Handling Precautions for SMC Products” (M-E03-3) before using.

SMC Corporation (Europe)

Austria	☎+43 (0)2262622800	www.smc.at	office@smc.at	Lithuania	☎+370 5 2308118	www.smclt.lt	info@smclt.lt
Belgium	☎+32 (0)33551464	www.smcpnautics.be	info@smcpneumatics.be	Netherlands	☎+31 (0)205318888	www.smcpnautics.nl	info@smcpneumatics.nl
Bulgaria	☎+359 (0)2807670	www.smc.bg	office@smc.bg	Norway	☎+47 67129020	www.smc-norge.no	post@smc-norge.no
Croatia	☎+385 (0)13707288	www.smc.hr	office@smc.hr	Poland	☎+48 222119600	www.smc.pl	office@smc.pl
Czech Republic	☎+420 541424611	www.smc.cz	office@smc.cz	Portugal	☎+351 226166570	www.smc.eu	postpt@smc.smces.es
Denmark	☎+45 70252900	www.smcdk.com	smc@smcdk.com	Romania	☎+40 213205111	www.smcromania.ro	smcromania@smcromania.ro
Estonia	☎+372 6510370	www.smcpnautics.ee	smc@smcpneumatics.ee	Russia	☎+7 8127185445	www.smc-pneumatik.ru	info@smc-pneumatik.ru
Finland	☎+358 207513513	www.smc.fi	smc@smc.fi	Slovakia	☎+421 (0)413213212	www.smc.sk	office@smc.sk
France	☎+33 (0)164761000	www.smc-france.fr	info@smc-france.fr	Slovenia	☎+386 (0)73885412	www.smc.si	office@smc.si
Germany	☎+49 (0)61034020	www.smc.de	info@smc.de	Spain	☎+34 902184100	www.smc.eu	post@smc.smces.es
Greece	☎+30 210 2717265	www.smchellas.gr	sales@smchellas.gr	Sweden	☎+46 (0)86031200	www.smc.nu	post@smc.nu
Hungary	☎+36 23513000	www.smc.hu	office@smc.hu	Switzerland	☎+41 (0)523963131	www.smc.ch	info@smc.ch
Ireland	☎+353 (0)14039000	www.smcpnautics.ie	sales@smcpneumatics.ie	Turkey	☎+90 212 489 0 440	www.smcpnomatik.com.tr	info@smcpnomatik.com.tr
Italy	☎+39 0292711	www.smcitalia.it	mailbox@smcitalia.it	UK	☎+44 (0)845 121 5122	www.smcpnautics.co.uk	sales@smcpneumatics.co.uk
Latvia	☎+371 67817700	www.smc.lv	info@smclv.lv				

SMC CORPORATION Akihbara UDX 15F, 4-14-1, Sotokanda, Chiyoda-ku, Tokyo 101-0021, JAPAN Phone: 03-5207-8249 FAX: 03-5298-5362